

# DCS800

## Hardware Manual DCS800 Drives (20 to 5200 A)





DCS800 Drives  
20 to 5200 A

## **Hardware Manual**

3ADW000194R0611 Rev F  
EFFECTIVE: 15.09.2008

© 2008 ABB Automation Products GmbH. All rights reserved.



# Safety instructions

---

## What this chapter contains

This chapter contains the safety instructions which you must follow when installing, operating and servicing the drive. If ignored, physical injury or death may follow, or damage may occur to the drive, the motor or driven equipment. Read the safety instructions before you work on the unit.

## To which products this chapter applies

This chapter applies to the DCS800... Size D1 to D7 and field exciter units DCF800...

## Use of warnings and notes

There are two types of safety instructions throughout this manual: warnings and notes. Warnings caution you about conditions which can result in serious injury or death and/or damage to the equipment. They also tell you how to avoid the danger. Notes draw attention to a particular condition or fact, or give information on a subject. The warning symbols are used as follows:



**Dangerous voltage warning** warns of high voltage which can cause physical injury and/or damage to the equipment.



**General warning** warns about conditions, other than those caused by electricity, which can result in physical injury and/or damage to the equipment.



**Electrostatic discharge warning** warns of electrostatic discharge which can damage the equipment.

## Installation and maintenance work

These warnings are intended for all who work on the drive, motor cable or motor. Ignoring the instructions can cause physical injury or death.



---

**Only qualified electricians are allowed to install and maintain the drive.**

- Never work on the drive, motor cable or motor when main power is applied. Always ensure by measuring with a multimeter (impedance at least 1 Mohm) that:
  1. Voltage between drive input phases U1, V1 and W1 and the frame is close to 0 V.
  2. Voltage between terminals C1 and D1 and the frame is close to 0 V.
- Do not work on the control cables when power is applied to the drive or to the external control circuits. Externally supplied control circuits may cause dangerous voltages inside the drive even when the main power on the drive is switched off.
- Do not make any insulation or voltage withstand tests on the drive or drive modules.
- When reconnecting the motor cable, always check that the C1 and D1 terminal is correct.

**Note:**

- The motor cable terminals on the drive are at a dangerously high voltage when the input power is on, regardless of whether the motor is running or not.
  - Depending on the external wiring, dangerous voltages (115 V, 220 V or 230 V) may be present on the terminals of relay outputs SDCS-IOB-2, RDIO.
  - DCS800 with enclosure extension: Before working on the drive, isolate the whole drive from the supply.
-



**WARNING!** The printed circuit boards contain components sensitive to electrostatic discharge. Wear a grounding wrist band when handling the boards. Do not touch the boards unnecessarily.

---

## Grounding

These instructions are intended for all who are responsible for the grounding of the drive. Incorrect grounding can cause physical injury, death or equipment malfunction and increase electromagnetic interference.

---



- Ground the drive, motor and adjoining equipment to ensure personnel safety in all circumstances, and to reduce electromagnetic emission and pick-up.
- Make sure that grounding conductors are adequately sized as required by safety regulations.
- In a multiple-drive installation, connect each drive separately to protective earth (PE).
- Minimize EMC emission and make a 360° high frequency grounding of screened cable entries at the cabinet lead-through.
- Do not install a drive with EMC filter on an ungrounded power system or a high resistance-grounded (over 30 ohms) power system.

### Note:

- Power cable shields are suitable for equipment grounding conductors only when adequately sized to meet safety regulations.
  - As the normal leakage current of the drive is higher than 3.5 mA AC or 10 mA DC (stated by EN 50178, 5.2.11.1), a fixed protective earth connection is required.
-

## Fibre optic cables

---



**WARNING!** Handle the fibre optic cables with care. When unplugging optic cables, always grab the connector, not the cable itself. Do not touch the ends of the fibres with bare hands as the fibre is extremely sensitive to dirt. The minimum allowed bend radius is 35 mm (1.4 in.).

---

## Mechanical installation

These notes are intended for all who install the drive. Handle the unit carefully to avoid damage and injury.

---



- DCS800 Size D4...D7: The drive is heavy. Do not lift it alone. Do not lift the unit by the front cover. Place the unit only on its back.

DCS800 Size D6/D7: The drive is heavy. Lift the drive by the lifting lugs only. Do not tilt the unit. The unit will overturn from a tilt of about 6 degrees.



- Make sure that dust from drilling does not enter the drive when installing. Electrically conductive dust inside the unit may cause damage or lead to malfunction.
  - Ensure sufficient cooling.
  - Do not fasten the drive by riveting or welding.
-



## Operation

These warnings are intended for all who plan the operation of the drive or operate the drive. Ignoring the instructions can cause physical injury or death or damage the equipment.



- Before adjusting the drive and putting it into service, make sure that the motor and all driven equipment are suitable for operation throughout the speed range provided by the drive. The drive can be adjusted to operate the motor at speeds above and below the base speed.
- Do not activate automatic fault reset functions of the Standard Application Program if dangerous situations can occur. When activated, these functions will reset the drive and resume operation after a fault.
- Do not control the motor with the disconnecting device (disconnecting switch); instead, use the control panel keys  and , or commands via the I/O board of the drive.
- Mains connection  
You can use a switch disconnecter (with fuses) in the power supply of the thyristor power converter to disconnect the electrical components of the unit from the power supply for installation and maintenance work. The type of disconnecter used must be a switch disconnecter as per EN 60947-3, Class B, so as to comply with EU regulations, or a circuit-breaker type which switches off the load circuit by means of an auxiliary contact causing the breaker's main contacts to open. The mains disconnecter must be locked in its "OPEN" position during any installation and maintenance work.
- EMERGENCY STOP buttons must be installed at each control desk and at all other control panels requiring an emergency stop function. Pressing the STOP button on the control panel of the thyristor power converter will neither cause an emergency motor stop, nor will the drive be disconnected from any dangerous potential.  
To avoid unintentional operating states, or to shut the unit down in case of any imminent danger according to the standards in the safety instructions it is **not** sufficient to **merely** shut down the drive via signals "RUN", "drive OFF" or "Emergency Stop" respectively "control panel" or "PC tool".
- Intended use the operating instructions cannot take into consideration every possible system configuration, operation or maintenance. Thus, they mainly give such advice only, which is required by qualified personnel for normal operation of the machines and devices in industrial installations.

If in special cases the electrical machines and devices are intended for use in non-industrial installations - which may require stricter safety regulations (e.g. protection against contact by children or similar). These additional safety measures for the installation must be provided by the customer during assembly.

**Note:**

- When the control location is not set to Local (**L** not shown in the PC tool status row), the stop key on the control panel will not stop the drive.
-

# Table of contents

---

DCS800 Drive Manuals .....	2
----------------------------	---

## **Safety instructions**

What this chapter contains .....	5
To which products this chapter applies .....	5
Use of warnings and notes .....	5
Installation and maintenance work .....	6
Grounding .....	7
Fibre optic cables .....	8
Mechanical installation .....	8
Operation .....	9

## **Table of contents**

### **The DCS800**

What this chapter contains .....	15
The DCS800 .....	15
Type code .....	16
Main circuit and control .....	17
Armature circuit converter DCS800-S0x D1...D4 .....	17
Armature circuit converter DCS800-S0x D5...D7 .....	18
Rebuild system DCS800-R0x .....	19

### **Mechanical installation**

Unpacking the unit .....	21
Delivery check .....	21
Before installation .....	22
Requirements for the installation site .....	22
Wall .....	22
Floor .....	22
Free space around the unit .....	22
Cabinet installation .....	22
Preventing cooling air recirculation .....	22
Unit above another .....	22
Terminal options converter size D1...D4 .....	23
Connection of DC terminals of D4 converter module .....	23
Terminal cover according to VBG 4 regulations .....	23
Mounting the converter module D6 inside an enclosure .....	25
Mounting the converter module D7 inside an enclosure .....	26

### **Planning the electrical installation**

---

What this chapter contains	27
To which products this chapter applies	27
Options for the drive	27
Line reactors	27
Line reactors LL1	29
Line reactors LL1 for North America	30
Aspects of fusing for the armature-circuit and field supplies of DC drives	31
General	31
Conclusion for the armature supply	31
Conclusion for the field supply	32
Semiconductor type F1 fuses and fuse holders for AC and DC power lines	33
Fuses F3.x and fuse holders for field supply	33
Single-phase Transformer T3 for field supply to match voltage levels	34
Single-phase Commutating reactor	35
Auxiliary transformer T2 for electronic system / fan supply	35
Residual current detection	35
EMC filters	36
Three-phase filters	36
Converters D1...D4 drive configuration using 'on board' field exciter	40
Converters D5 drive configuration using 'FEX-425-Int' field exciter	41
Converters D5...D7 drive configuration using 'external' field exciter DCF803, DCF804	42
Converters D1...D3 3-phase field exciter configuration	43
START, STOP and E-STOP control	44
Drive configuration with reduced components	46
Fan cooling	47
Thermal overload and short-circuit protection	49
Mains cable (AC line cable) short-circuit protection	49
Cross-sectional areas - Tightening torques	50
Typical Cable Sizing and Tightening Torque – North America	51
Selecting the control cables	52
DCS800 panel cable	52
Connection of a motor temperature sensor to the drive I/O	53

### **Electrical installation**

What this chapter contains	55
Checking the insulation of the assembly	55
IT (ungrounded) systems	56
Supply voltage	56
Connecting the power cables	56
Location R-Extension and Interface Modules	57
I/O Board Configuration	58
Pulse encoder connection	59
Pulse encoder receiver	60
Connecting the signal and control cables	62
Routing the cables	62
DCS Link Wiring	63

### **Installation checklist**

Checklist . . . . .	65
---------------------	----

### **Maintenance**

What this chapter contains . . . . .	67
Safety . . . . .	67
Maintenance intervals . . . . .	67
Heatsink . . . . .	68
Fan . . . . .	68
Fan replacement (D6, D7) . . . . .	68

### **Technical data**

What this chapter contains . . . . .	69
Environmental Conditions . . . . .	69
Current ratings - IEC non regenerative . . . . .	71
Current ratings - IEC regenerative . . . . .	72
Sizing . . . . .	72
Duty cycle . . . . .	72
Current ratings – North America non-regenerative . . . . .	73
Current ratings – North America regenerative . . . . .	74
Control Board SDCS-CON-4 . . . . .	75
Layout of the control board SDCS-CON-4 . . . . .	75
Memory circuit. . . . .	75
Watchdog function . . . . .	75
Seven segment display . . . . .	76
Terminal description . . . . .	76
Digital and analogue I/O connection of the SDCS-CON-4 . . . . .	78
Interface Board SDCS-COM-8. . . . .	79
Ch2 SDCS-COM-8 Master-Follower connections . . . . .	80
Ch0 Drive Bus connection to Advant Controller (star) . . . . .	80
Ch0 Connection to overriding control (Nxxx fieldbus adapter) . . . . .	81
Ch3 Ring connection to PC tool DriveWindow . . . . .	81
Ch3 Star connection to PC tool DriveWindow . . . . .	82
DDCS Branching unit NDBU-95. . . . .	83
SDCS-DSL Board. . . . .	84
Digital I/O board SDCS-IOB-2 . . . . .	85
Analogue and encoder I/O board SDCS-IOB-3 . . . . .	87
Power Supply Board SDCS-POW-4. . . . .	89
Interface Board SDCS-PIN-4 . . . . .	90
General . . . . .	90
Power supply . . . . .	91
Technical data. . . . .	91
Armature circuit interface . . . . .	92
Field circuit interface . . . . .	92
Power Interface SDCS-PIN-46/SDCS-PIN-48/SDCS-PIN-5x . . . . .	94
Interface Board SDCS-SUB-4 . . . . .	98
General . . . . .	98
Galvanic isolation - T90, A92 . . . . .	100
DC-DC transducer A92 . . . . .	102

Transformer T90 .....	103
-----------------------	-----

### **Dimensional drawings**

Module D1 .....	105
Module D2 .....	105
Module D3 .....	105
Module D4 .....	106
Module D5 .....	107
Module D6 .....	108
Module D7 left-hand .....	109
Module D7 right-hand .....	110
Fuses installed inside the converter .....	111

### **Accessories**

DCF803-0035 and FEX 425 internal .....	113
Electrical data .....	114
Control unit .....	114
Power section .....	114
DCS LINK communication .....	115
Diagnosis .....	116
RS232-Port .....	117
FEX425 INTERNAL (Fex-425-Int) Hardware configuration (size D5) .....	117
Dimensions .....	118
DCF505 / DCF506 Overvoltage Protection .....	119
Fuses and fuse holders IEC .....	122
Fuses and fuse holders - North America .....	123
Dimensions .....	123
Line reactors IEC .....	124
Line reactors type ND 01...ND 17 .....	124
Line reactors type ND 07...ND 12 .....	125
Line reactors type ND 401...ND 413 .....	127
Line reactors – North America .....	129
Autotransformer T3 .....	130
Line reactor L3 .....	130
Supply transformer T2 for electronics and fan .....	131
Optical cables .....	132
Other cables .....	133

# The DCS800

---

## What this chapter contains

This chapter describes briefly the operating principle and construction of the converter modules in short.

## The DCS800

The DCS800-S size D1...D7 are intended for controlling DC motors.



**Size D1...D4**  
20...1000 A



**Size D5**  
900...2000 A



**Size D6**  
1900...3000 A



**Size D7**  
2050...5200





# Main circuit and control

## Armature circuit converter DCS800-S0x D1...D4

400 V and 500 V units with Onboard field exciter  
 600 V units are always without Onboard field exciter

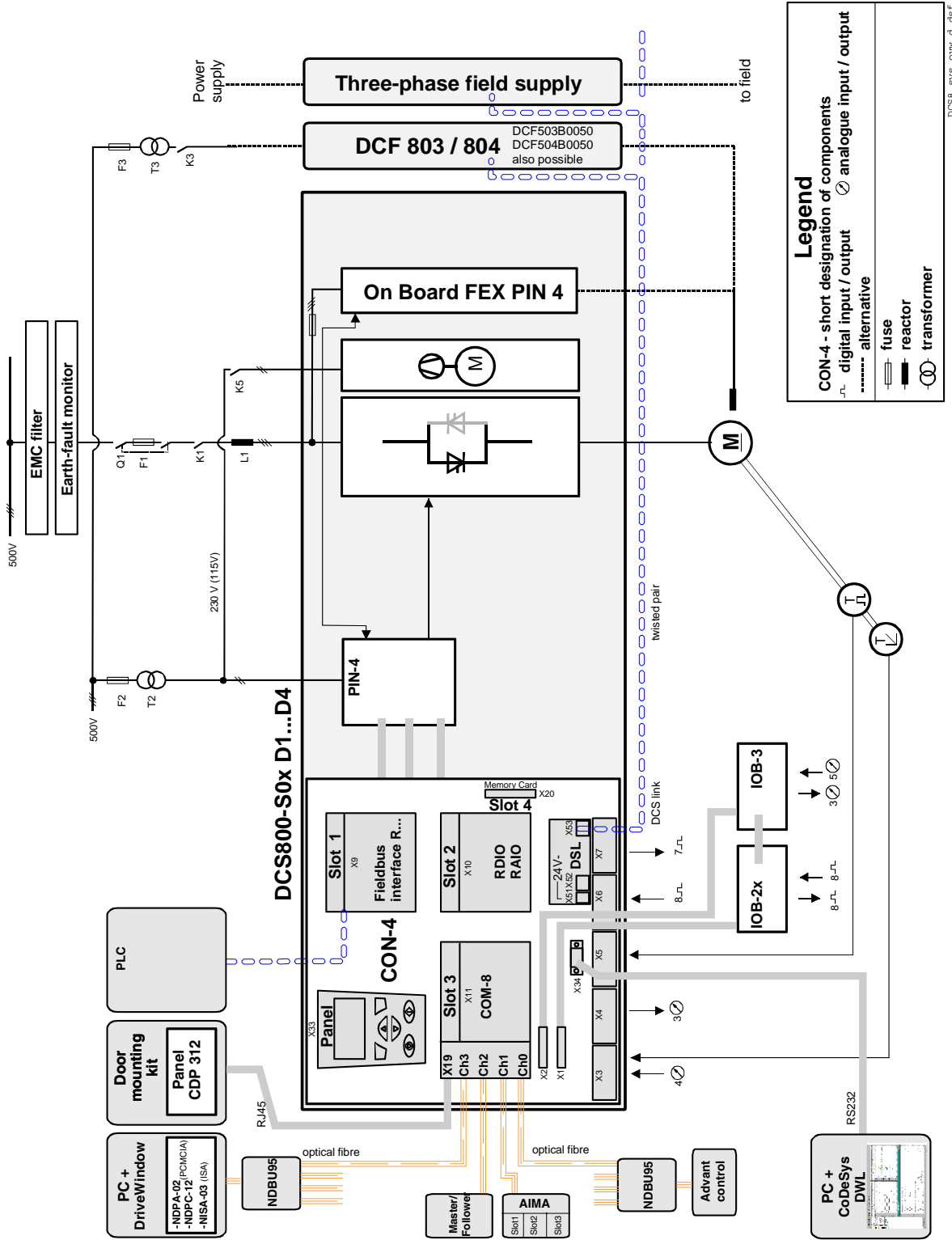

### Armature circuit converter DCS800-S0x D5...D7

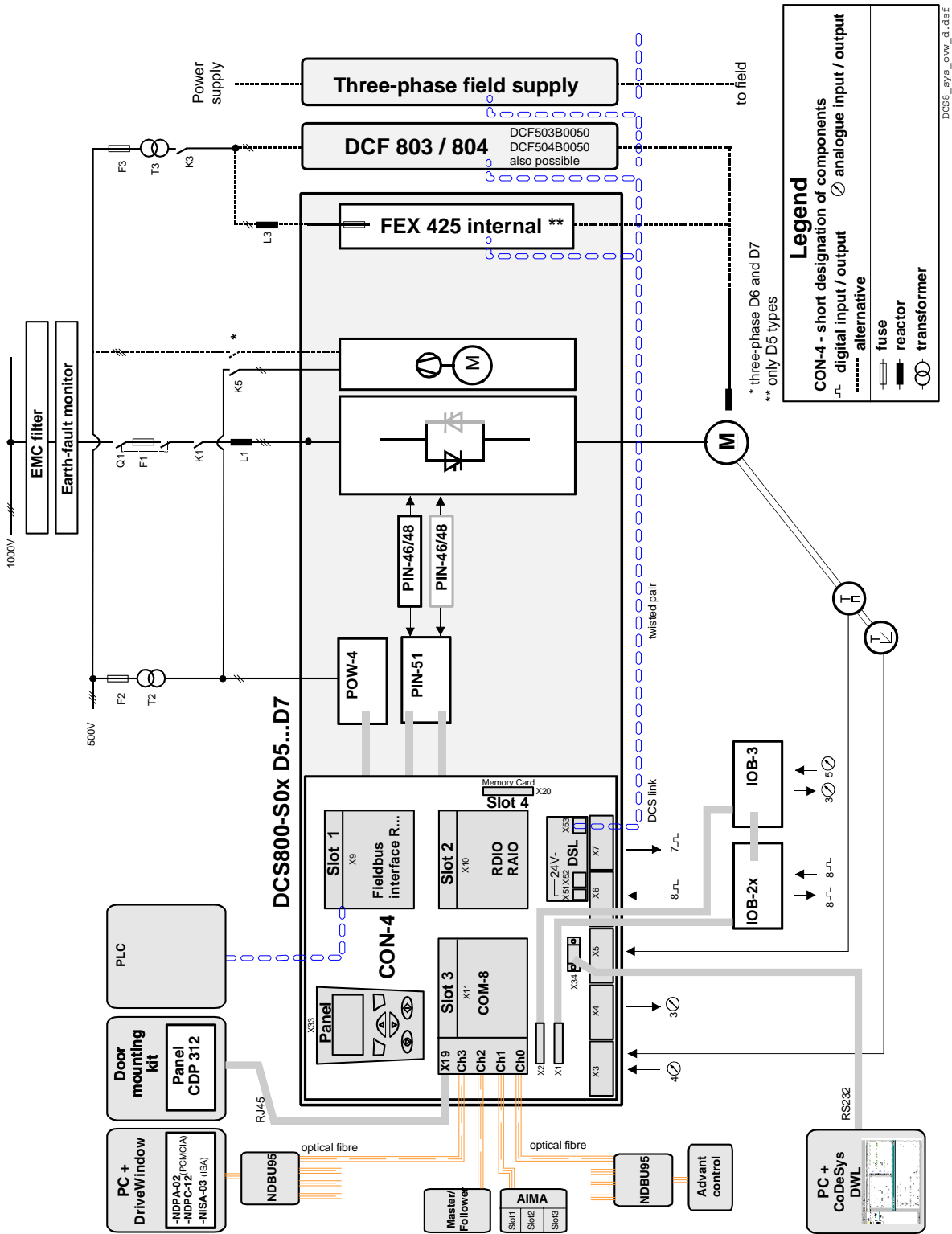





# Mechanical installation

## Unpacking the unit

- open box
- take out shock dampers
- separate manual and accessories
- do not lift the drive by cover.

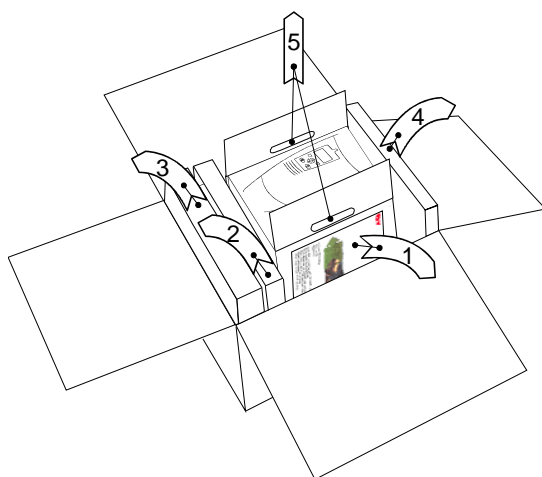

## Delivery check

Check that there are no signs of damage. Before attempting installation and operation, check the information on the type designation label of the drive to verify that the unit is of the correct type. The label includes an IEC rating,  $cUL_{US}$  and CE markings, a type code and a serial number, which allow individual identification of each unit. The remaining digits complete the serial number so that there are no two units with the same serial number.

Example labels are shown below.

ABB Automation Products GmbH		Made in Germany		Fan	115/230 V	
Type: DCS800-S02-0260-05	$U_1$	3-525	V	$U_2$	520	$V_{DC}$
Ser No: 0025421A5294264	$I_1$	212	A	$I_2$	260	A
	$I_f$			$I_F$	15	A

Rated input voltage

Rated input current

Rated internal  
field exciter current

Rated output current

Rated fan voltage

Plus code

+K454  
+J409

## Before installation

The drive must be installed in an upright position with the cooling section facing a wall. Check the installation site according to the requirements below. Refer to [Dimensional drawings](#) for frame details.

### Requirements for the installation site

See [Technical data](#) for the allowed operation conditions of the drive.

#### Wall

The wall should be as close to vertical as possible, of non-flammable material and strong enough to carry the weight of the unit. Check that there is nothing on the wall to inhibit the installation.

#### Floor

The floor/material below the installation should be non-flammable.

#### Free space around the unit

Required free space around the drive to enable cooling air flow, service and maintenance see chapter [Dimensional drawings](#).

## Cabinet installation

The required distance between parallel units is five millimetres (0.2 in.) in installations without the front cover. The cooling air entering the unit must not exceed +40 °C (+104 °F).

### Preventing cooling air recirculation

Prevent air recirculation inside and outside the cabinet.

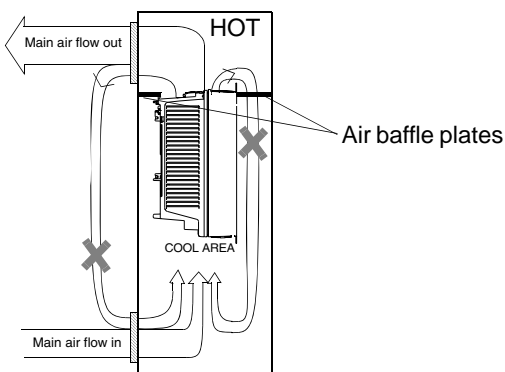

### Unit above another

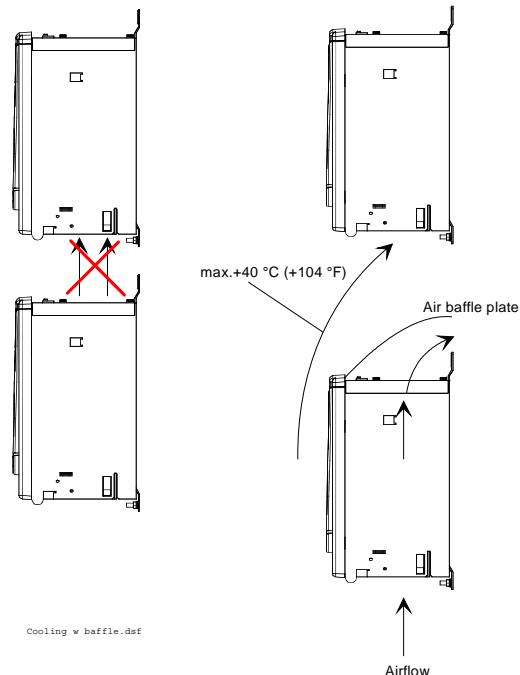

Lead the exhaust cooling air away from the unit above. Distances see chapter [Dimensional drawings](#)

## Terminal options converter size D1...D4

There are different options for protection and connection the terminals for converter sizes D1...D4

### Connection of DC terminals of D4 converter module

In special cases it is beneficial to use the lug bar for easier connection of the DC cables.

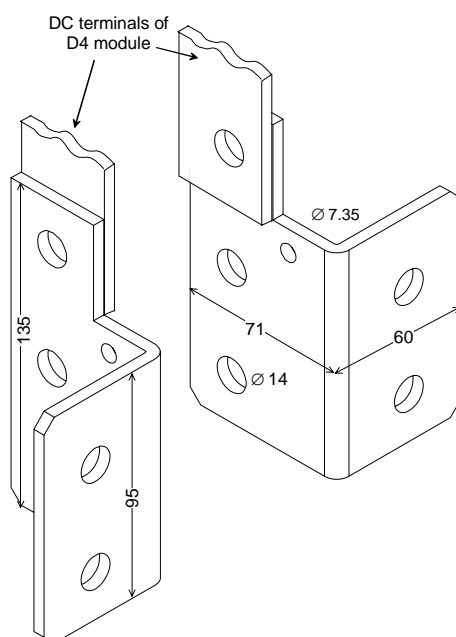

Id No.	Remark
3ADV280706P0001	right
3ADV280706P0002	left

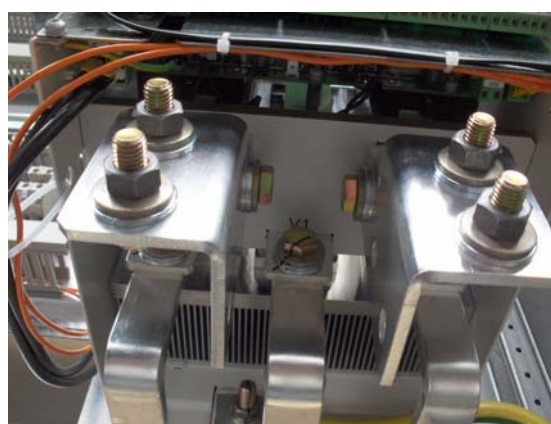

Bottom view of lug bar mounted on a D4 module

### Terminal cover according to VBG 4 regulations

For converter modules D1...D4 we provide shrouds for protection against contact

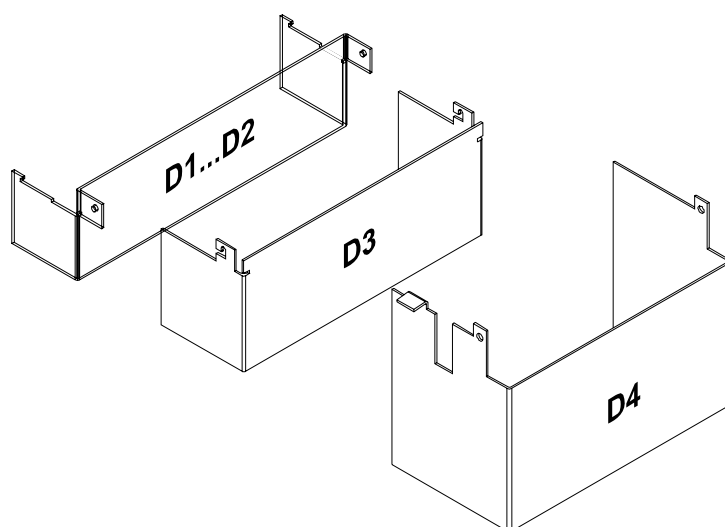

Id No.	Remark
3ADT631137P0001	D1...D2
3ADV400208P0001	D3
3ADV400207P0001	D4

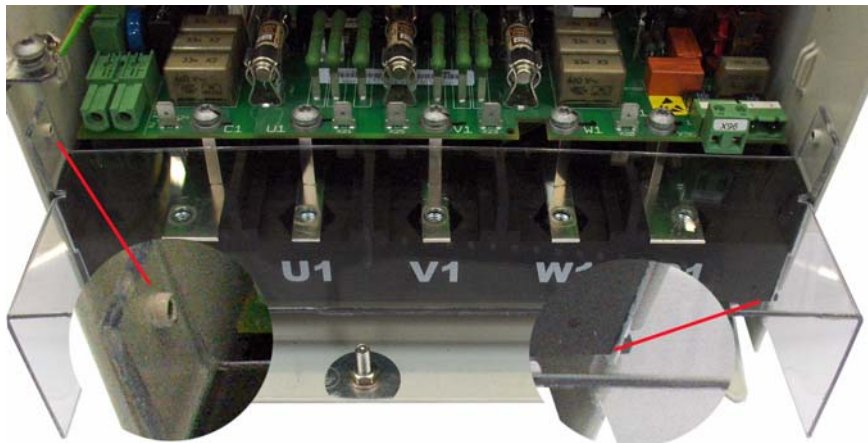

*Mounting the D1/D2 cover by using the existing lateral pins and then swing downward to snap-in at the terminal row. D3 and D4 mounting is accordingly, without the snap-in mechanism.*



*Examples for covering the DC main terminals on D3 (left) and D4 (right) converter modules.*





# Mounting the converter module D7 inside an enclosure

## Cooling air entry

The cooling fan takes the air from the backside, both sides and from the area underneath the converter module.

View from front

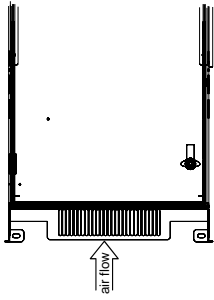

left side / (right side)

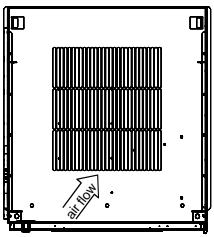
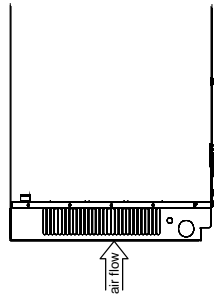

View from bottom

## Free space around the converter module

Do not place the converter module in a corner. In case the fan cannot take the air through the bottom plate of the enclosure none of the remaining entries can be blocked.

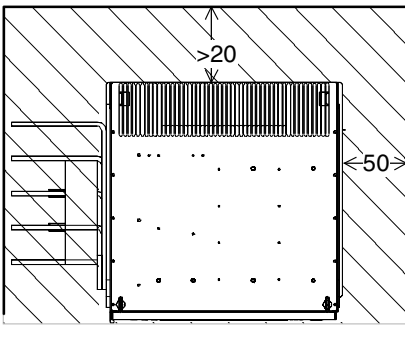

## Air entry through bottom plate

Make sure the converter module gets clean air, because there is no air filter in front of the fan at the converter.

## Cooling air outlet

To avoid circulating air inside the enclosure it is recommended to make sure the exhaust air leaves the enclosure.

## Cable entries

The cable entries are existing symmetrically on both sides. Nevertheless only the entries on the left side should be used for cables going to the electronics power supply (SDCS-POW-1) or the controller board (SDCS-CON-4).

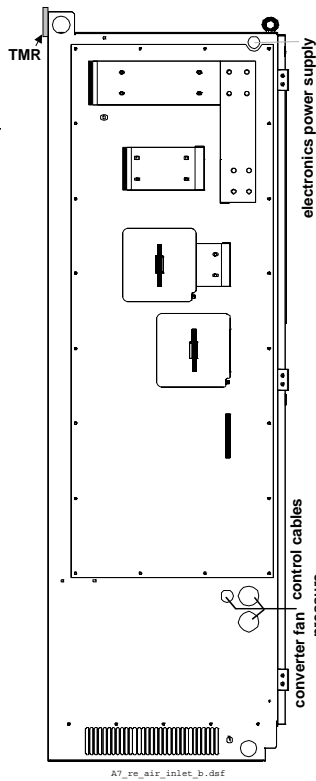

Screened cable for hardware interface connection IOB2/IOB3 board is strongly recommended

Provide sufficient grounding of card holder

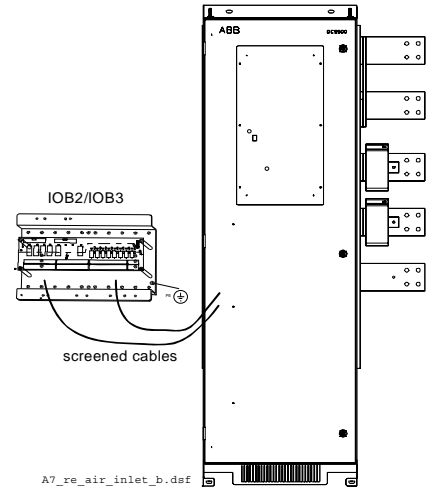

Internal cable ducts are used for snubber circuit wiring. Don't use these cable ducts for other cables or process signals.

Use cable straps for fan cable

Do not have loose cables. The air flow from fan will destroy the cables!

# Planning the electrical installation

---

## What this chapter contains

This chapter contains the instructions that you must follow when selecting the motor, cables, protections, cable routing and way of operation for the drive system. Always follow local regulations.

**Note:** If the recommendations given by ABB are not followed, the drive may experience problems that the warranty does not cover.

**Reference:** *Technical Guide* - publ. no.: 3ADW000163

## To which products this chapter applies

This chapter applies to the DCS800-S Size D1...D7.

## Options for the drive

### Line reactors

for armature (DCS800) and field (DCF800) supply.

When thyristor power converters operate, the line voltage is short-circuited during commutation from one thyristor to the next. This operation causes voltage dips in the mains PCC (point of common coupling). For the connection of a power converter system to the mains, one of the following configurations can be applied:

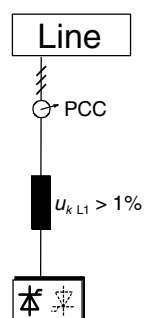

### Configuration A

When using the power converter, a minimum of impedance is required to ensure proper performance of the snubber circuit. A line reactor can be used to meet this minimum impedance requirement. The value must therefore not drop below 1%  $u_k$  (relative impedance voltage). It should not exceed 10%  $u_k$ , due to considerable voltage drops at converter output.

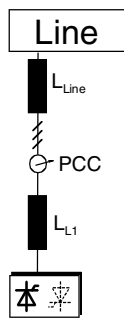

### Configuration B

If special requirements have to be met at the PCC (standards like EN 61 800-3, DC and AC drives at the same line, etc), different criteria must be applied for selecting a line reactor. These requirements are often defined as a voltage dip in percent of the nominal supply voltage.

The combined impedance of  $Z_{Line}$  and  $Z_{L1}$  constitute the total series impedance of the installation. The ratio between the line impedance and the line reactor impedance determines the voltage dip at the connecting point. In such cases line chokes with an impedance around 4% are often used.

Example calculation with  $U_{k Line}=1\%$ ;

$U_{k L1}=4\%$ ; **Voltage Dip =  $Z_{Line}/(Z_{Line}+Z_{L1})=20\%$** . Detailed calculation see *Technical Guide*.

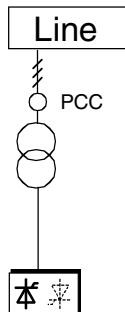

### Configuration C

If an isolation transformer is used, it is possible to comply with certain connecting conditions per Configuration B without using an additional line reactor. The condition described in Configuration A will then likewise be satisfied, since the  $u_k$  is  $>1\%$ .

### Configuration C1

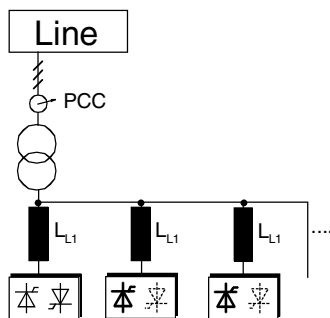

Netzdr\_g.dsf

If 2 or more converters should be supplied by one transformer the final configuration depends on the number of drives in use and their power capability. Configuration A or B has to be used which are based on commutation chokes, if the drive system consists of any of the converters (D1, D2, D3, D4, D5, D6, D7). In case only two converters type D7 are involved no commutation chokes are necessary because the design of these converters is adapted to that wiring.

#### **With reference to the power converter:**

The line reactors listed in table below

- have been sized to the units nominal current
- are independent of converter's voltage classification; at some converter types the same line choke is used up to 690 V line voltage
- are based on a duty cycle
- can be used for DCS800 as armature converter as well as field converter but rated line choke current must be considered.

You will find further information in publication:

**Technical Guide** chapter: *Line reactors*

### Line reactors $L_{L1}$

DCS Type 400V-690V 50/60 Hz		Line choke type for configur. A	Design Fig.	Line choke type for configur. B	Design Fig.
2-Q Converter	4-Q Converter				
DCS800-S01-0020-04/05	DCS800-S02-0025-04/05	ND01	1	ND401	4
DCS800-S01-0045-04/05	DCS800-S02-0050-04/05	ND02	1	ND402	4
DCS800-S01-0065-04/05	DCS800-S02-0075-04/05	ND04	1	ND403	5
DCS800-S01-0090-04/05	DCS800-S02-0100-04/05	ND06	1	ND404	5
DCS800-S01-0125-04/05	DCS800-S02-0140-04/05	ND06	1	ND405	5
DCS800-S01-0180-04/05	DCS800-S02-0200-04/05	ND07	2	ND406	5
DCS800-S01-0230-04/05	DCS800-S02-0260-04/05	ND07	2	ND407	5
DCS800-S01-0290-06	DCS800-S02-0320-06	ND08	2	on request	-
DCS800-S01-0315-04/05	DCS800-S02-0350-04/05	ND09	2	ND408	5
DCS800-S01-0405-04/05	DCS800-S02-0450-04/05	ND10	2	ND409	5
DCS800-S01-0590-06	DCS800-S02-0650-06	ND13	3	on request	-
DCS800-S01-0470-04/05	DCS800-S02-0520-04/05	ND10	2	ND410	5
DCS800-S01-0610-04/05	DCS800-S02-0680-04/05	ND12	2	ND411	5
DCS800-S01-0740-04/05	DCS800-S02-0820-04/05	ND13	3	ND412	5
DCS800-S01-0900-04/05	DCS800-S02-1000-04/05	ND13	3	ND413	5
DCS800-S01-0900-06/07	DCS800-S02-0900-06/07	ND13	3	on request	-
DCS800-S01-1200-04/05	DCS800-S02-1200-04/05	ND14	3	on request	-
DCS800-S01-1500-04/05/06/07	DCS800-S02-1500-04/05/06/07	ND15	3	on request	-
DCS800-S01-2000-04/05	DCS800-S02-2000-04/05	ND16	3	on request	-
DCS800-S01-2000-06/07		ND16 *	3	on request	-

\* with forced cooling (1m/s)

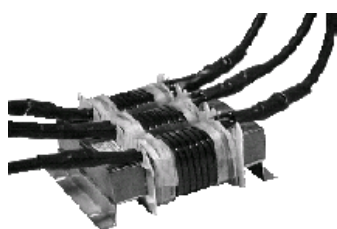

Fig. 1

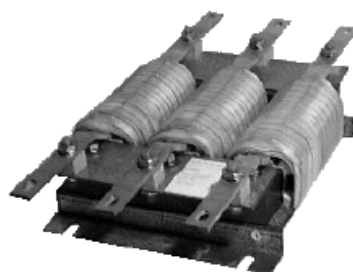

Fig. 2



Fig. 3

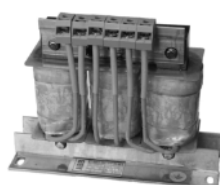

Fig. 4



Fig. 5

*Line reactors  $L_{L1}$  for North America*

Unit Type		Line Choke for Config. A	Line Choke for Config. B
2Q Converters	4Q Converters	1.5% imp.	5% imp.
<b>500 Vdc</b>			
DCS800-S01-0020-05	DCS800-S02-0025-05	KLR21BTB	KLR21CTB
DCS800-S01-0045-05	DCS800-S02-0050-05	KLR45BTB	KLR45CTB
DCS800-S01-0065-05	DCS800-S02-0075-05	KLR80BTB	KLR80CTB
DCS800-S01-0090-05	DCS800-S02-0100-05	KLR110BCB	KLR110CCB
DCS800-S01-0125-05	DCS800-S02-0140-05	KLR130BCB	KLR130CCB
DCS800-S01-0180-05	DCS800-S02-0200-05	KLR200BCB	KLR200CCB
DCS800-S01-0230-05	—	KLR200BCB	KLR200CCB
—	DCS800-S02-0260-05	KLR250BCB	KLR250CCB
DCS800-S01-0315-05	DCS800-S02-0350-05	KLR300BCB	KLR300CCB
DCS800-S01-0405-05	—	KLR360BCB	KLR360CCB
DCS800-S01-0470-05	DCS800-S02-0450-05	KLR420BCB	KLR420CCB
—	DCS800-S02-0520-05	KLR480BCB	KLR480CCB
DCS800-S01-0610-05	DCS800-S02-0680-05	KLR600BCB	KLR600CCB
DCS800-S01-0740-05	DCS800-S02-0820-05	KLR750BCB	KLR750CCB
DCS800-S01-0900-05	—	KLR750BCB	KLR750CCB
—	DCS800-S02-1000-05	KLR850BCB	KLR850CCB
DCS800-S01-1200-05	DCS800-S02-1200-05	KLR1100BCB	KLR1100CCB
DCS800-S01-1500-05	DCS800-S02-1500-05	KLR1250BCB	KLR1250CCB
<b>600 Vdc</b>			
DCS800-S01-0290-06	—	KLR250BCB	KLR250ECB
—	DCS800-S02-0320-06	KLR300BCB	KLR300ECB
DCS800-S01-0590-06	DCS800-S02-0650-06	KLR600BCB	KLR600ECB
DCS800-S01-0900-06	DCS800-S02-0900-06	KLR750BCB	KLR750ECB
DCS800-S01-1500-06	DCS800-S02-1500-06	KLR1250BCB	KLR1250ECB

Recommended AC Line Reactors are available directly from TCI.

For information, see their web page [www.transcoil.com](http://www.transcoil.com)



## Aspects of fusing for the armature-circuit and field supplies of DC drives

### General

#### Unit configuration

Protection elements such as fuses or overcurrent trip circuits are required in all cases to protect against further damage. In some configurations, this will entail the following questions: first, at what point should which protective element be incorporated? And secondly, in the event of what faults will the element in question provide protection against damage?

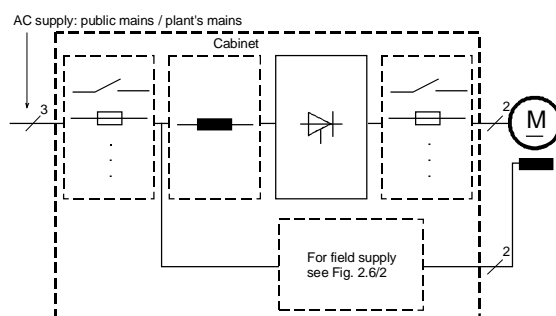

The figure shows the arrangement of the switch-off elements in the armature-circuit converter

You will find further information in publication:

**Technical Guide** chapter: *Aspects for fusing*

#### Conclusion for the armature supply

In no case standard fusing should be used instead of semi-conductor fusing in order to save money on installation.

In the event of a fault condition, the small amount of money saved can cause the semiconductors or other devices explode and could also cause fires.

Adequate protection against **short-circuit** and **earth fault**, as depicted in the **EN50178** standard, is possible only with **appropriate semiconductor fuses**.

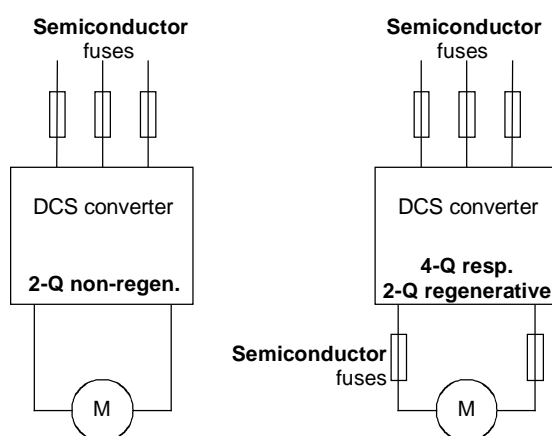

### Conclusion for the field supply

Basically, similar conditions apply for both field supply and armature-circuit supply. Depending on the power converter used (half-controlled bridge, fully controlled 4-quadrant bridge), some of the fault sources may not always be applicable. Due to special system conditions, such as supply via an autotransformer or an isolating transformer, new protection conditions may additionally apply.

The following configurations are very often used:

In contrast to the armature-circuit supply, fuses are never used on the DC side for the field supply, since a fuse trip might under certain circumstances lead to greater damage e.g. (small, but long-lasting overcurrent; fuse ageing; contact problems; etc.).

Semiconductor fuse F3.1 (super-fast acting) should be used, if conditions similar to those for armature-circuit supply (4-Q operation) are to apply, like for example protection of the field supply unit and the field winding.

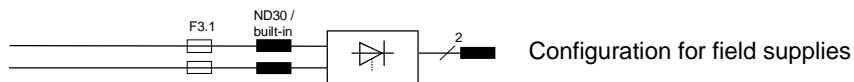

The F3.2 and F3.3 fuse types serve as line protectors and **cannot protect the field supply** unit. Only pure HRC fuses or miniature circuit-breakers may be used. Semiconductor fuses would be destroyed, for example, by the transformer's starting current inrush.

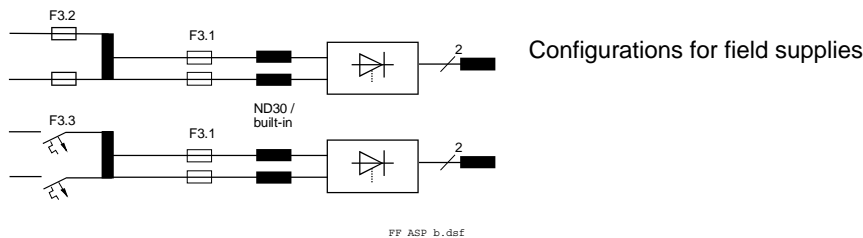



## Semiconductor type F1 fuses and fuse holders for AC and DC power lines (DCS800-S01 / DCS800-S02)

The converter units are subdivided into two groups:

- Unit sizes D1, D2, D3 and D4 with rated currents up to 1000 A require external fuses.
- In unit sizes D5, D6 and D7 with rated currents of 900 A to 5200 A, the branch semiconductor fuses are installed internally (no additional external semiconductor fuses are needed).

The third column of the table below assigns the AC fuse type to the converter type. In case the converter should be equipped with DC fuses according to the hints, use the same type of fuse as on AC side at DC side (C1, D1). Blade type fuses are used for all the converters construction type D1...D4 except the converters (610 A, 680 A, 740 A, 820 A, 900 A, 1000 A).

Type of converter		Size	Fuse type	Fuse holder	Type	Fuse Holder
2-Q Converter	4-Q Converter				North America	
DCS800-S01-0020-04/05	DCS800-S02-0025-04/05	D1	170M 1564	OFAX 00 S3L	FWP-50B	1BS101
DCS800-S01-0045-04/05	DCS800-S02-0050-04/05		170M 1565	OFAX 00 S3L	FWP-80B	1BS101
DCS800-S01-0065-04/05	DCS800-S02-0075-04/05		170M 1568	OFAX 00 S3L	FWP-125A	1BS103
DCS800-S01-0090-04/05	DCS800-S02-0100-04/05		170M 1568	OFAX 00 S3L	FWP-125A	1BS103
DCS800-S01-0125-04/05	DCS800-S02-0140-04/05		170M 3815	OFAX 1 S3	FWP-200A	1BS103
DCS800-S01-0180-04/05	DCS800-S02-0200-04/05	D2	170M 3816	OFAX 1 S3	FWP-250A	1BS103
DCS800-S01-0230-04/05	DCS800-S02-0260-04/05		170M 3817	OFAX 1 S3	FWP-300A	1BS103
DCS800-S01-0315-04/05	DCS800-S02-0350-04/05	D3	170M 5810	OFAX 2 S3	FWP-500A	1BS103
DCS800-S01-0405-04/05	DCS800-S02-0450-04/05		170M 6811	OFAX 3 S3	FWP-700A	See Note 1
DCS800-S01-0470-04/05	DCS800-S02-0520-04/05		170M 6811	OFAX 3 S3	FWP-700A	See Note 1
DCS800-S01-0610-04/05	DCS800-S02-0680-04/05	D4	170M 6163	3x 170H 3006	FWP-900A	See Note 1
DCS800-S01-0740-04/05	DCS800-S02-0820-04/05		170M 6163	3x 170H 3006	FWP-900A	See Note 1
DCS800-S01-0900-04/05	DCS800-S02-1000-04/05		170M 6166	3x 170H 3006	FWP-1200A	See Note 1
DCS800-S01-0290-06	DCS800-S02-0320-06	D3	170M 5810	OFAX 2 S3	FWP-500A	See Note 1
DCS800-S01-0590-06	DCS800-S02-0650-06	D4	170M 6813	OFAX 3 S3	FWP-900A	See Note 1

Fuses and fuse holders (details see chapter *Technical Data*)

Note 1: No fuse holder is available. Attach fuses directly to busbar.

## Fuses F3.x and fuse holders for field supply

Depending on the protection strategy different types of fuses are to be used. The fuses are sized according to the nominal current of the field supply device. If the field supply unit is connected to two phases of the network, two fuses should be used; in case the unit is connected to one phase and neutral only one fuse at the phase can be used. Table below lists the fuse currents with respect to the table above.

The fuses can be sized according to the maximum field current. In this case take the fuse, which fits to the rated field current levels.

Field conv.	Field current	F3.1	F3.2	F 3.3
DCF803-0035	$I_F \leq 6$ A	170M 1558 *	OFAA 00 H10	10 A
FEX-425-Int *	$I_F \leq 12$ A	170M 1559 *	OFAA 00 H16	16 A
DCF803	$I_F \leq 16$ A	170M 1561 *	OFAA 00 H25	25 A
DCF804	$I_F \leq 25$ A	170M 1564 *	OFAA 00 H25	35 A
DCF803	$I_F \leq 35$ A	170M 1564	OFAA 00 H50	50 A
DCF804				
DCF803	$I_F \leq 50$ A	170M 1565	OFAA 00 H63	63 A
DCF804				
Type of protection elements		Semiconduct. type fuse for fuse holder type OFAX 00	LV HRC type for 690 V; fuse hold. OFAX 00	circuit breaker for 500 V or 690 V

\* F3.1 Fuse KTK25 included in FEX-425-Int inside D5 converter module

Fuses and fuse holders for 2-phase field supply

**Single-phase Transformer T3 for field supply to match voltage levels**

The field supply units' insulation voltage is higher than the rated operating voltage (see Chapter *Field supplies*), thus providing an option in systems of more than 500 V for supplying the power section of the converter directly from the mains for purposes of armature supply, and using an autotransformer to match the field supply to its rated voltage. Moreover, you can use the autotransformer to reduce the voltage ripple. Different types (primary voltages of 400...500 V and of 525...690 V) with different rated currents each are available.

Field converter type $\leq 500$ V; 50/60 Hz	for field current $I_F$	Transformer type 50/60 Hz
external supply		
DCF803-0035 FEX-425-Int	$\leq 6$ A	$U_{prim} = \leq 500$ V T 3.01
	$\leq 12$ A	T 3.02
	$\leq 16$ A	T 3.03
DCF803/4-0050 DCF803/4-0050	$\leq 30$ A	T 3.04
	$\leq 50$ A	T 3.05
DCF803-0035 FEX-425-Int	$\leq 6$ A	$U_{prim} = \leq 600$ V T 3.11
	$\leq 12$ A	T 3.12
	$\leq 16$ A	T 3.13
DCF803/4-0050 DCF803/4-0050	$\leq 6$ A	$U_{prim} = \leq 690$ V T 3.11
	$\leq 12$ A	T 3.12
	$\leq 16$ A	T 3.13
	$\leq 30$ A	T 3.14
	$\leq 50$ A	T 3.15

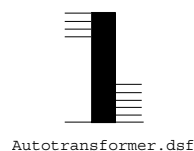

Autotransformer.dsf

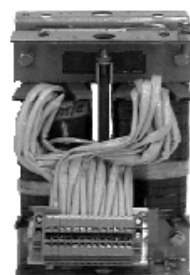

T3 autotransformer

Autotransformer data (details see chapter *Technical Data*)

### Single-phase Commutating reactor

For DCF803-0016, DCF803-0035 and FEX-425-Int field power converter with external supply must be connected via additionally commutating reactor because of EMC considerations if the supply has a separate mains. With DCF803/804-0050 and DCF503B/504B-0050 field power converters, it is already installed.

Converter 500 V; 50/60 Hz	for field current $I_F$	Reactor	
		IEC	US
DCF803-0016 DCF803-0035 (16 A) FEX-425-Int	16 A	ND 30	KLR 45 CTB
	>16A	* ND 402	

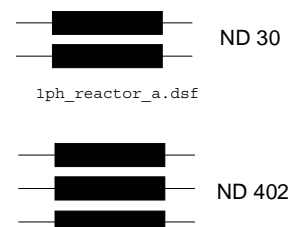

\* 3-phase operation or single-phase operation

Commutating reactor (for more information see chapter *Accessories*)

### Auxiliary transformer T2 for electronic system / fan supply

The converter unit requires various auxiliary voltages, e.g. the unit's electronics require 115 V/1-ph or 230 V/1-ph, the unit fans require 230 V/1-ph or 400 V/690 V/3-ph, according to their size. The T2 auxiliary transformer is designed to supply the unit's electronic system and all the single-phase fans including the fan of the D5 converter

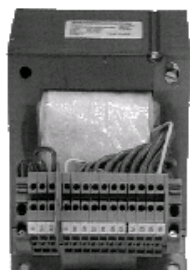

Input voltage: 380...690 V/1-ph; 50/60 Hz  
Output voltage: 115/230 V/1-ph  
Power: 1400 VA

### Residual current detection

This function detects current to ground. If needed, the analogue input AI4 of the SDCS-IOB-3 board has to be activated, a current signal of the three phase currents should be supplied to AI4 by a current transformer.

## EMC filters

### Filter in a grounded line (earthed TN or TT network)

The filters are suitable for grounded lines only, for example in public European 400 V lines.

According to EN 61800-3 filters are not needed in insulated industrial networks with own supply transformers. Furthermore they could cause safety risks in such floating lines (IT networks).

According to EN 61800-3 filters are not needed in industrial zone (Second Environment) for DCS800 drives above 100 A rated current. For rated currents below 100 A the filter requirement is identical to Light Industry (First Environment).

### Three-phase filters

EMC filters are necessary to fulfil the standard for emitted interference if a converter shall be run at a public low voltage line, in Europe for example with 400 V. Such lines have a grounded neutral conductor. ABB offers suitable three-phase filters for 400 V and 25 A...600 A and 500 V filters for 440 V lines outside Europe. The filters can be optimized for the real motor currents:

$I_{\text{Filter}} = 0.8 \cdot I_{\text{MOT max}}$  ; the factor 0.8 respects the current ripple.

Lines with 500 V to 1000 V are not public. They are local networks inside factories, and they do not supply sensitive electronics. Therefore converters do not need EMC filters if they shall run with 500 V and more.

Type of converter				Constr. type	Filter type f. y=4	Filter type f. y= 5
2-Q Converter		4-Q Converter				
	IDC [A]		IDC [A]			
DCS800-S01-0020-0y	20A	DCS800-S02-0025-0y	25A	D1	NF3-440-25	NF3-500-25
DCS800-S01-0045-0y	45A	DCS800-S02-0050-0y	50A	D1	NF3-440-50	NF3-500-50
DCS800-S01-0065-0y	65A	DCS800-S02-0075-0y	75A	D1	NF3-440-64	NF3-500-64
DCS800-S01-0090-0y	90A	DCS800-S02-0100-0y	100A	D1	NF3-440-80	NF3-500-80
DCS800-S01-0125-0y	125A	DCS800-S02-0140-0y	140A	D1	NF3-440-110	NF3-500-110
DCS800-S01-0180-0y	180A	DCS800-S02-0200-0y	200A	D2	NF3-500-320	NF3-500-320
DCS800-S01-0230-0y	230A	DCS800-S02-0260-0y	260A	D2	NF3-500-320	NF3-500-320
DCS800-S01-0315-0y	315A	DCS800-S02-0350-0y	350A	D3	NF3-500-320	NF3-500-320
DCS800-S01-0405-0y	405A	DCS800-S02-0450-0y	450A	D3	NF3-500-600	NF3-500-600
DCS800-S01-0470-0y	470A	DCS800-S02-0520-0y	520A	D3	NF3-500-600	NF3-500-600
DCS800-S01-0610-0y	610A	DCS800-S02-0680-0y	680A	D4	NF3-500-600	NF3-500-600
DCS800-S01-0740-0y	740A			D4	NF3-500-600	NF3-500-600
		DCS800-S02-0820-0y	820A	D4	NF3-690-1000 ①	NF3-690-1000 ①
DCS800-S01-0900-0y	900A	DCS800-S02-1000-0y	1000A	D4	NF3-690-1000 ①	NF3-690-1000 ①
DCS800-S01-0900-0y	900A	DCS800-S02-0900-0y	900A	D5	NF3-690-1000 ①	NF3-690-1000 ①
DCS800-S01-1200-0y	1200A	DCS800-S02-1200-0y	1200A	D5	NF3-690-1000 ①	NF3-690-1000 ①
DCS800-S01-1500-0y	1500A	DCS800-S02-1500-0y	1500A	D5	NF3-690-1600 ①	NF3-690-1600 ①
DCS800-S01-2000-0y	2000A	DCS800-S02-2000-0y	2000A	D5	NF3-690-1600 ①	NF3-690-1600 ①
	≤3000A		≤3000A	D6	NF3-690-2500 ①	NF3-690-2500 ①

① Filter only available on request

### Single-phase filters for field supply

Many field supply units are single-phase converters for up to 50 A excitation current. They can be supplied by two of the three input phases of the armature supply converter. Then a field supply unit does not need its own filter.

If the phase to neutral voltage shall be taken (230 V in a 400 V line) then a separate filter is necessary. ABB offers such filters for 250 V and 6...30 A.

Converter type of field supply unit	dc current [A]	Filter type ① $U_{\max} = 250 \text{ V}$
DCF803-0016 *	8	NF1-250-8
DCF803-0035 * FEX-425-Int *	16	NF1-250-20
DCF803-0050	50	NF1-250-55
DCF804-0050	50	NF1-250-55
further filters for	12	NF1-250-12
	30	NF1-250-30

① The filters can be optimized for the real field currents:  $I_{\text{Filter}} = I_{\text{Field}}$

\* single-phase operation

### EMC filters

You will find further information in publication:

**Technical Guide** chapter: *EMC Compliant Installation and Configuration for a Power Drive System*

The paragraphs below describe selection of the electrical components in conformity with the EMC Guideline. The aim of the EMC Guideline is, as the name implies, to achieve electromagnetic compatibility with other products and systems. The guideline ensures that the emissions from the product concerned are so low that they do not impair another product's interference immunity.

In the context of the EMC Guideline, two aspects must be borne in mind:

- the product's interference immunity

- the product's actual emissions

The EMC Guideline expects EMC to be taken into account when a product is being developed; however, EMC cannot be designed in, it can only be quantitatively measured.

#### Note on EMC conformity

The conformity procedure is the responsibility of both the power converter's supplier and the manufacturer of the machine or system concerned, in proportion to their share in expanding the electrical equipment involved.

<b>First environment (residential area with light industry) with PDS category C2</b>	
Not applied, since category C1 (general distribution sales channel) excluded	
<b>Not applicable</b>	<b>satisfied</b>
<b>satisfied</b>	

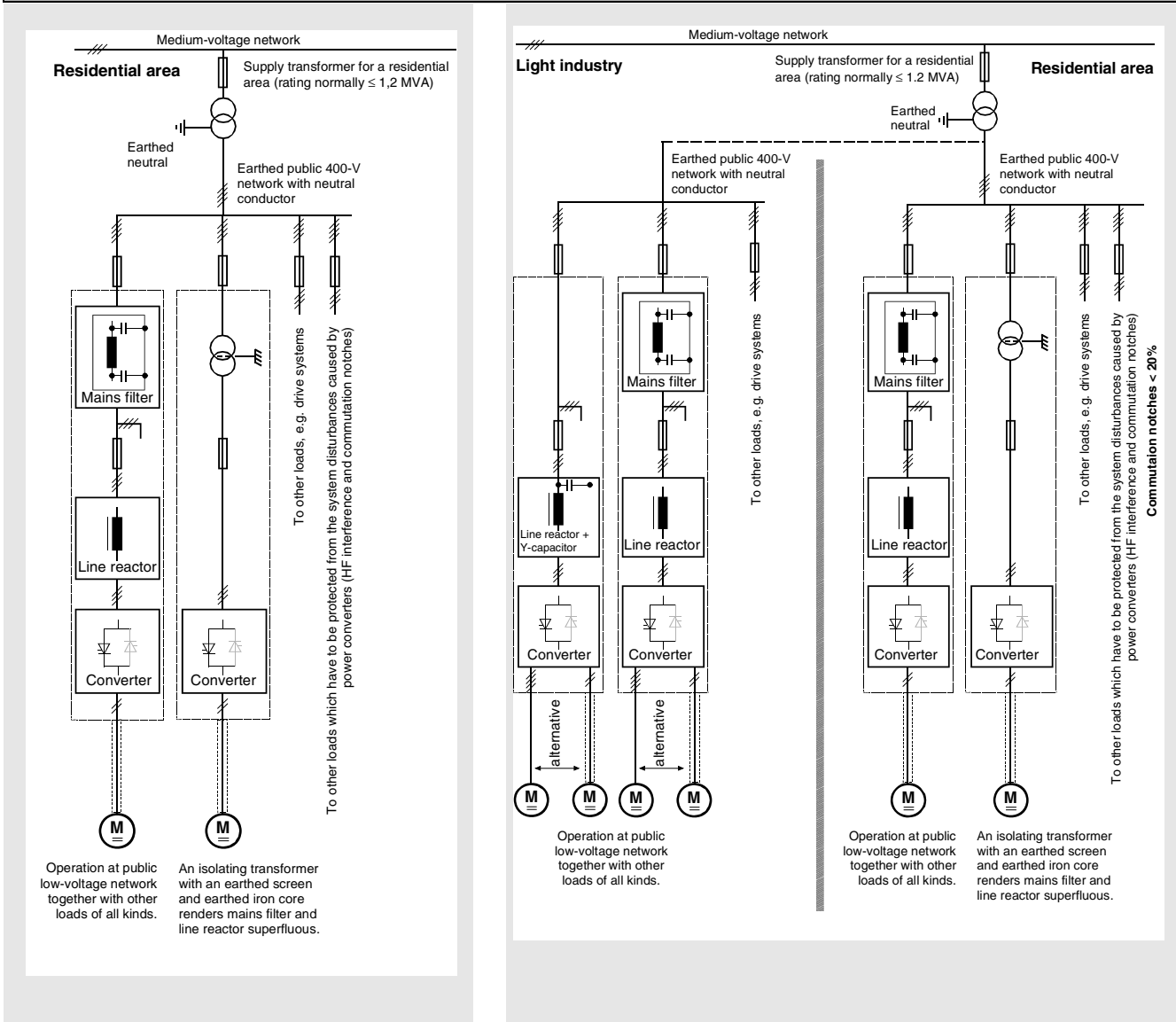

For compliance with the protection objectives of the German EMC Act (EMVG) in systems and machines, the following EMC standards must be satisfied:

**Product Standard EN 61800-3**

EMC standard for drive systems (PowerDriveSystem), interference immunity and emissions in residential areas, enterprise zones with light industry and in industrial facilities.

This standard must be complied with in the EU for satisfying the EMC requirements for systems and machines!

For emitted interference, the following apply:

**EN 61000-6-3** Specialised basic standard for emissions in **light industry** can be satisfied with special features (mains filters, screened power cables) in the lower rating range \*(EN 50081-1).

**EN 61000-6-4** Specialised basic standard for emissions in **industry** \*(EN 50081-2)

For interference immunity, the following apply:

**EN 61000-6-1** Specialised basic standard for interference immunity in **residential areas** \*(EN 50082-1)

**EN 61000-6-2** Specialised basic standard for interference immunity in **industry**. If this standard is satisfied, then the EN 61000-6-1 standard is automatically satisfied as well \*(EN 50082-2).

\* The old generic standards are given in brackets

Second environment (industry) with PDS categories C3, C4			Standards
Not applicable			EN 61800-3
satisfied	on customer's request	satisfied	EN 61000-6-3
satisfied			EN 61000-6-4
			EN 61000-6-2
			EN 61000-6-1

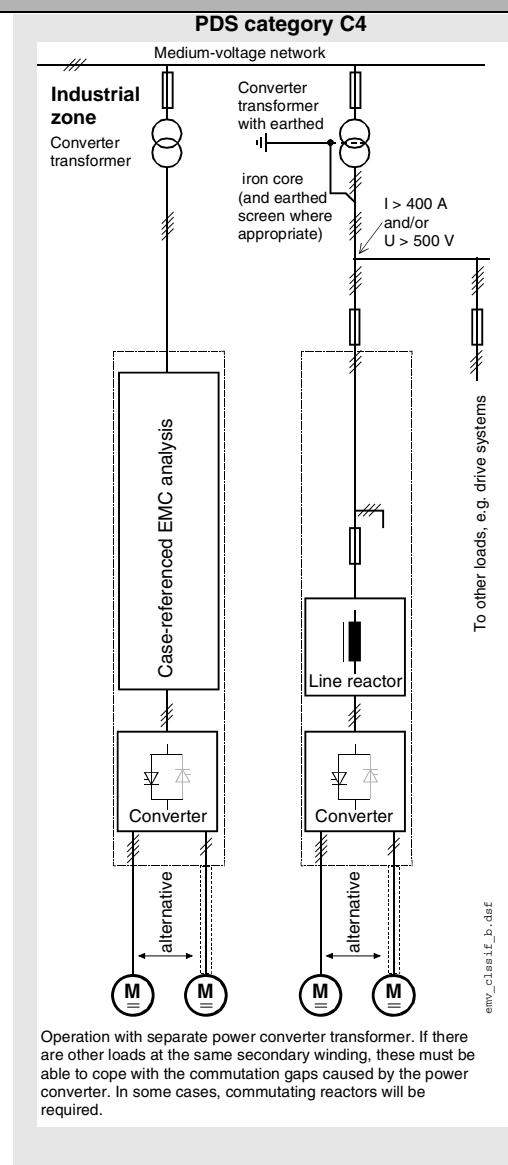
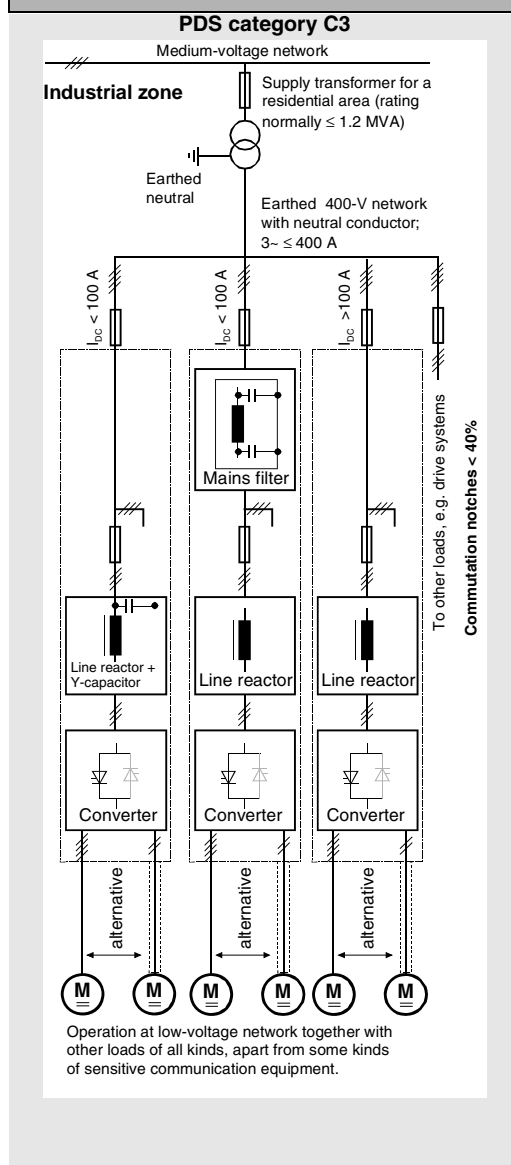

**Classification**

The following overview utilises the terminology and indicates the action required in accordance with Product Standard **EN 61800-3**

For the DCS800 series, the limit values for emitted interference are complied with, provided the measure indicated is carried out. PDS of category C2 (formerly restricted distribution in first environment) is intended to be installed and commissioned only by a professional (person or organization with necessary skills in installing and/or commissioning PDS including their EMC aspects).

For power converters without additional components, the following warning applies:

**This is a product of category C2 under IEC 61800-3:2004. In a domestic/residential environment this product may cause radio interference in which case supplementary mitigation measures may be required.**

The field supply is not depicted in this overview diagram. For the field current cables, the same rules apply as for the armature-circuit cables.

**Legend**

	Screened cable
	Unscreened cable with restriction

# Converters D1...D4 drive configuration using 'on board' field exciter

Wiring the drive according to this diagram offers the highest degree of monitoring functions done by the drive.

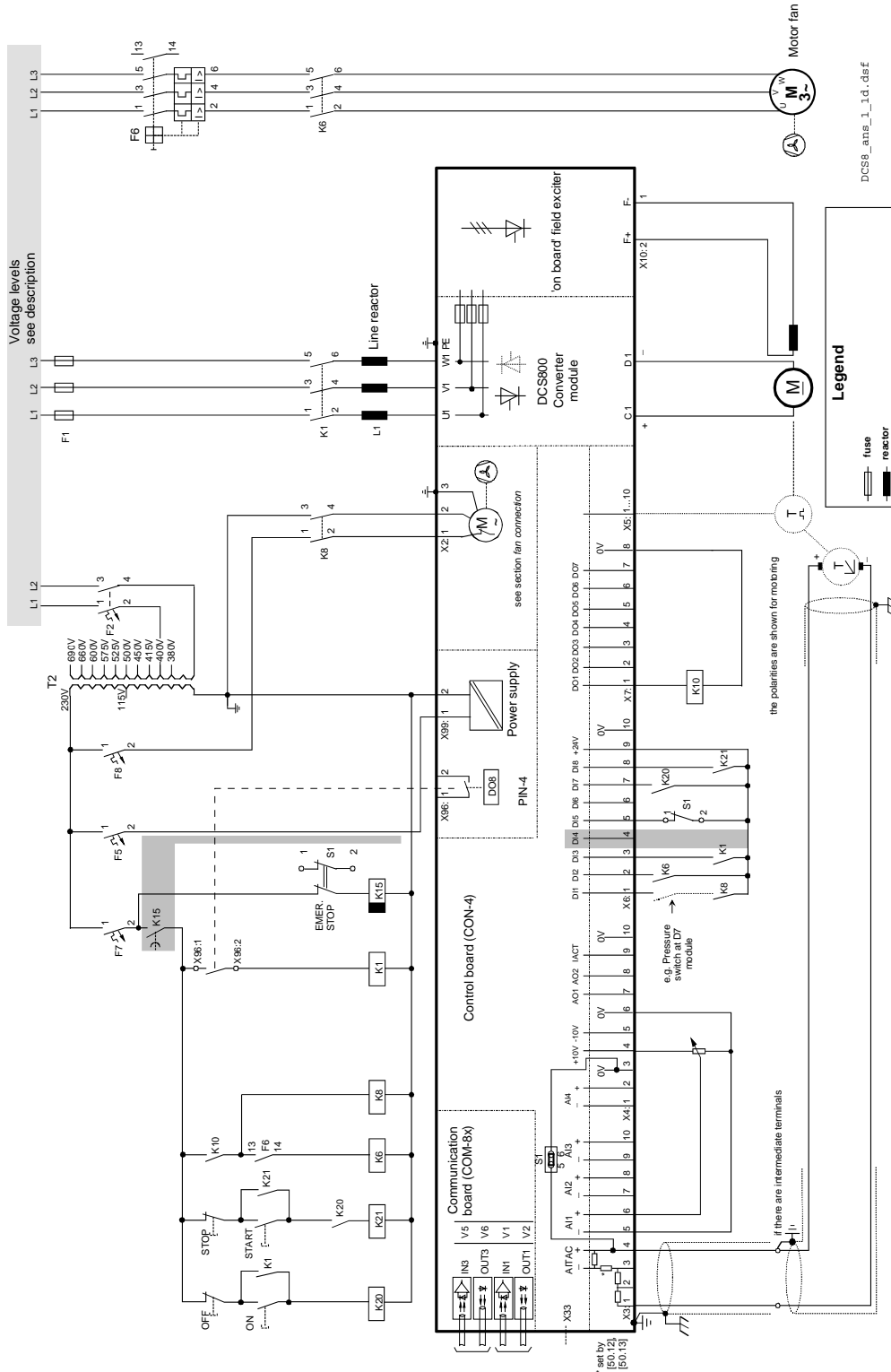

further information see drawing at page 43



## Converters D5 drive configuration using 'FEX-425-Int' field exciter

Wiring the drive according to this diagram gives the most flexibility and offers the highest degree of monitoring functions done by the drive. Field converters FEX-425-Int are equipped with their own synchronization and can be supplied from an independent net. FEX-425-Int can be supplied separate max. 500 V (3-phase), or 2-phase.

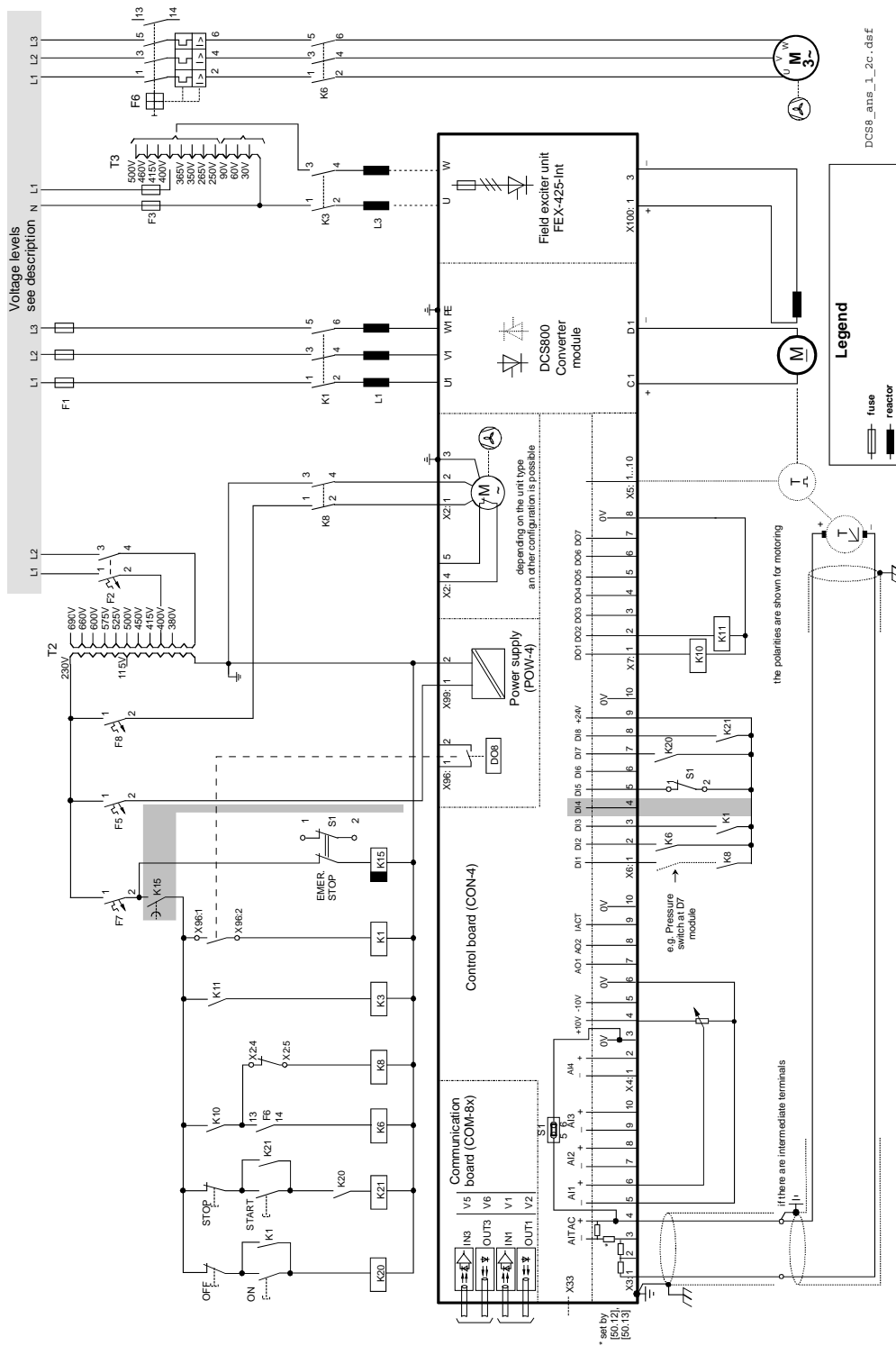

■ further information see drawing at page 43

# Converters D5...D7 drive configuration using 'external' field exciter DCF803, DCF804

Wiring the drive according to this diagram gives the most flexibility and offers the highest degree of monitoring functions done by the drive. Field converters DCF803 / DCF804 are equipped with their own synchronization and can be supplied from an independent net. DCF803-0035 can be supplied with 3-phase aux. supply.

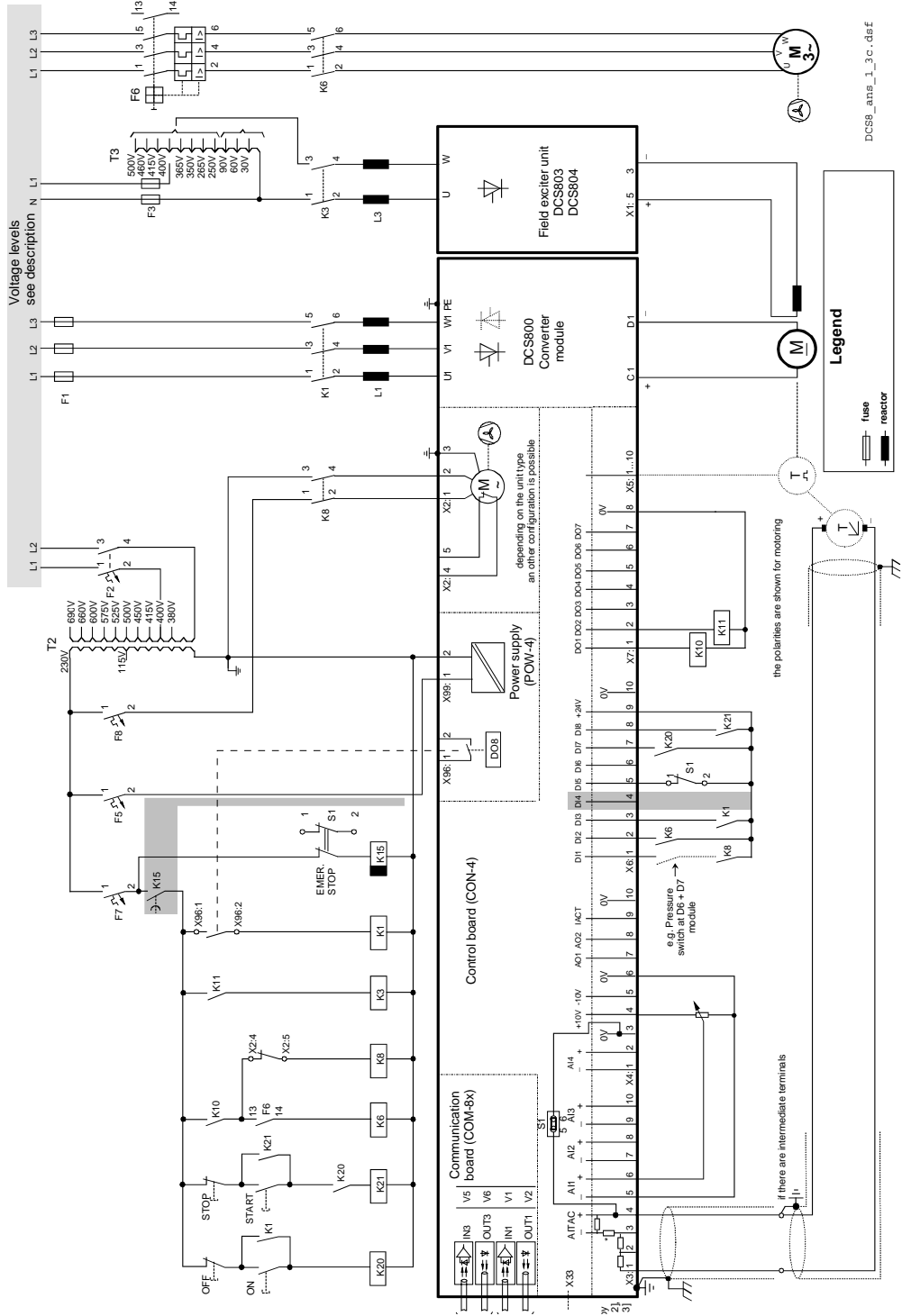

further information seedrawing at page 43

# Converters D1...D3 3-phase field exciter configuration

Wiring the drive according to this diagram offers the highest degree of monitoring functions done by the drive.

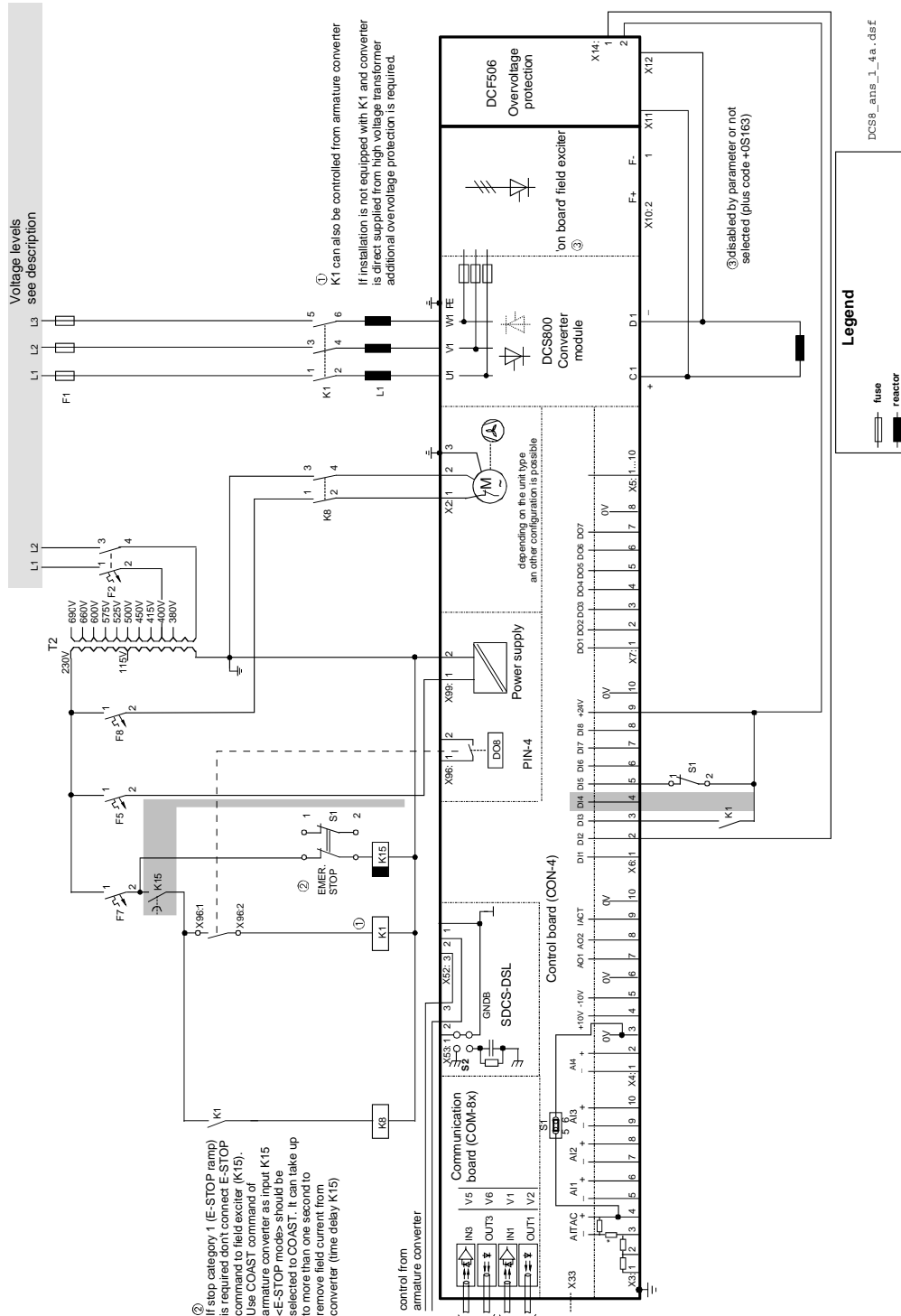

■ further information see drawing at page 43

## START, STOP and E-STOP control

The relay logic can be split into three parts:

### a: Generation of the ON/OFF and START/STOP command:

The commands represented by K20 and K21 (latching interface relay) can be e.g. generated by a PLC and transferred to the terminals of the converter either by relays, using galvanic isolation or directly via 24V signals. There is no need to use hardwired signals. These commands can be as well transferred via serial communication. Even a mixed solution can be realized by selecting different possibilities for the one or the other signal (see parameter group 11).

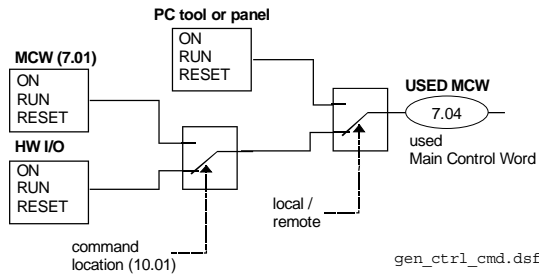

### b: Generation of control and monitoring signals:

The main contactor K1 for the armature circuit is controlled by a dry contact (DO 8) located on the SDCS-PIN-4. Status of fans and fans klixon can be monitored by means of fans ack signals: MotFanAck (10.06) and ConvFanAck (10.20).

### c: OFF2, OFF3 Stop function:

Beside ON/OFF and START/STOP the drive is equipped with two additional stop functions OFF2 and OFF3 according Profibus standard. OFF3 is a scalable stop function (rampstop, max torque stop, dynamic braking ...) to perform stop category 1. This function should be connected to the E-STOP button without any time delay. In case of ramp stop selection the K 15 timer relay must be set longer than EStopRamp (22.04). For COAST selection the drive opens the main contactor immediately.

OFF2 switches off DC current as fast as possible and prepares the drive for opening main contactor or drop down mains supply. For a normal DC motor load the time to switch OFF the DC current is below 20 ms. This function should be connected to all signals and safety functions opening the main contactor. This function is important for 4-quadrant drives. Do not open main contactor during regenerative current.

The correct sequence is

1. switch off regenerative current
2. then open the main contactor

In case of E-STOP is hit, the information is transferred to the converter via digital input DI 5. In case of (rampstop, or max torque selection) the converter will decelerate the motor and then open main contactor.

If the drive has not finished the function within the K15 timer setting, the drive must get the command to switch OFF the current via K16. After K16 timer set has elapsed the main contactor is opened independent of the drives status.

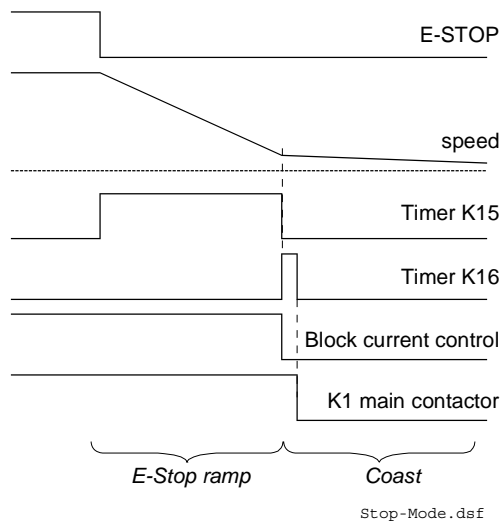
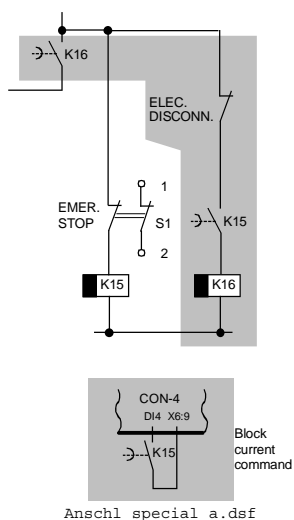

E-Stop reaction

**d: DC contactor US:**

DC contactor US K1.1 is a special designed contactor with 2x NO contacts for C1 and D1 connection and 1x NC contact for connection of Dynamic Brake resistor  $R_B$ . The contactor should be controlled by signal 6.03 Bit 10.

The acknowledge can be connected to parameter:

- 10.21 MainContAck
- 10.23 DCBreakAck

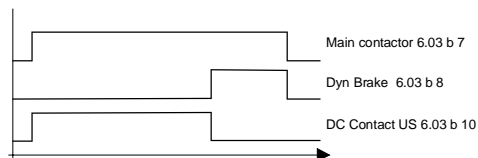
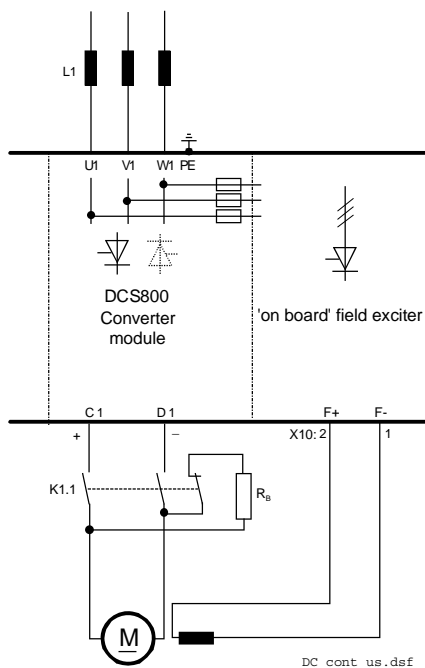

## Drive configuration with reduced components

Converters D1...D4 (400...500 V) using 'on board' field exciters  
 Converters D5 using FEX-425-Int field exciter, but externally supplied

Wiring the drive according to this diagram gives the same control performance, but a lower degree of flexibility. Dynamic Braking keeps the main contactor K1 in state ON during braking.

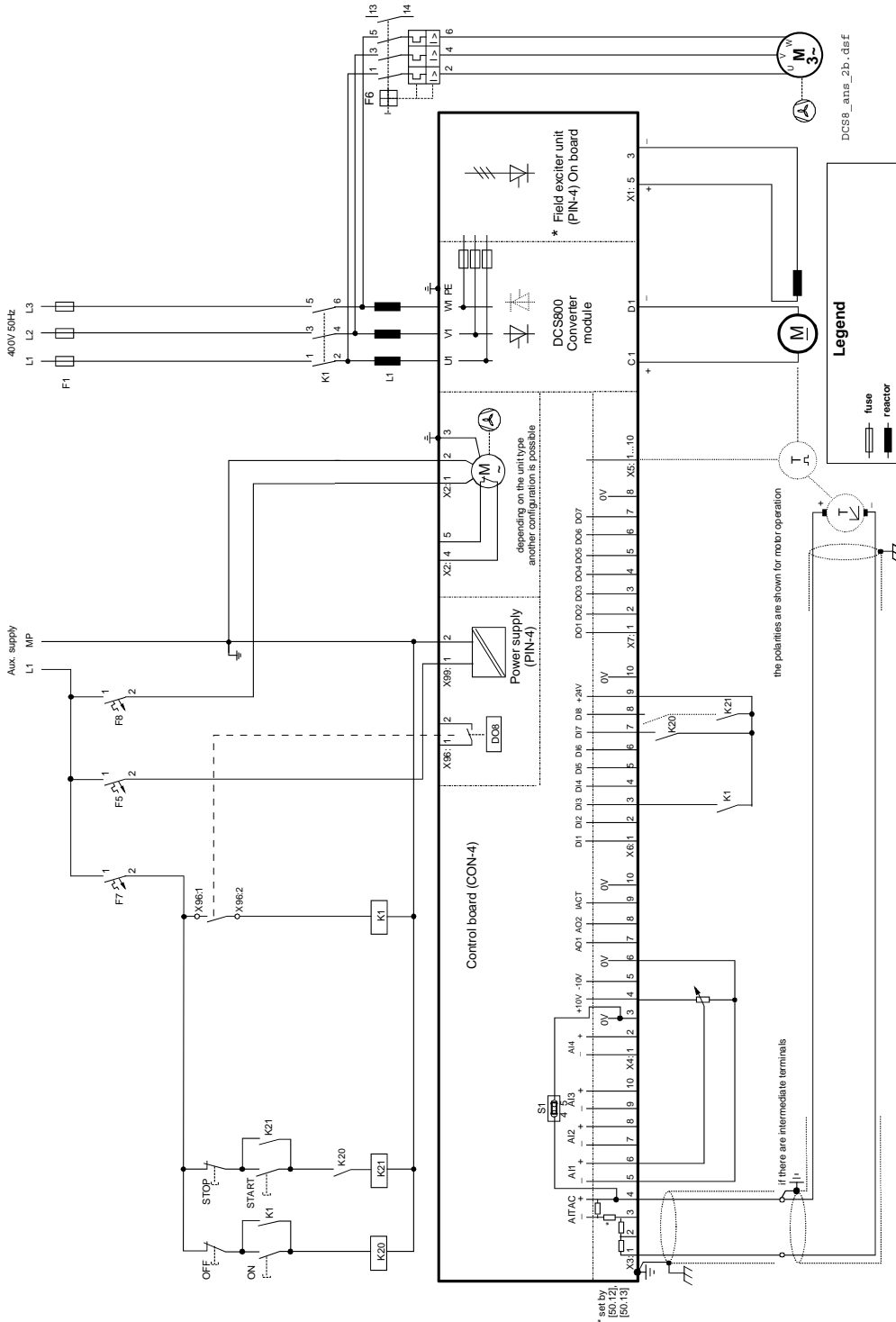

**Selection of components:** The wiring diagram is valid for a DCS800 converter construction type D1...D4 ≤525 V and D5 ≤500 V. The 'on board' field exciter (D1...D4) can be used at line voltages up to 525 V and will give field currents up to 6 / 15 / 20 / 25 A. For higher field currents, use the next larger field supply units DCF803/804 or a 3-phase field supply DCS800.

- \* D1-D4: On board field exciter (PIN-4)
- D5: FEX-425-Int field exciter, supplied external

## Fan cooling

### Fan assignment for DCS800

Converter type	Model	Configuration	Fan type
DCS800-S0x-0045-04/05 ... DCS800-S0x-00140-05/05	D1	1	2x CN2B2
DCS800-S0x-0180-04/05 ... DCS800-S0x-0260-04/05	D2	1	2x CN2B2
DCS800-S0x-0315-04/05 ... DCS800-S0x-0350-04/05	D3	1	2x CN2B2
DCS800-S0x-0405-04/05 ... DCS800-S0x-0520-04/05	D3	2	4x CN2B2
DCS800-S0x-0610-04/05 ... DCS800-S0x-0820-04/05	D4	3	1x W2E200 (230 V)
DCS800-S0x-0610-04/05 ... DCS800-S0x-0820-04/05	D4 Pluscode E171	3	1x W2E200 (115 V)
DCS800-S0x-0900-04/05 ... DCS800-S0x-1000-04/05	D4	3	1x W2E250 (230 V)
DCS800-S0x-0900-04/05 ... DCS800-S0x-1000-04/05	D4 Pluscode E171	3	1x W2E250 (115 V)
DCS800-S0x-0900-0y ... DCS800-S0x-2000-0y	D5	4	D2E 160
DCS800-S0x-1900-04/05/08... DCS800-S0x-3000-04/05/08	D6	5	GR31M 400...500 V
DCS800-S0x-1900-06/07 ... DCS800-S0x-3000-06/07	D6	5	GR31M 500...690 V
DCS800-S0x-3300-yy... DCS800-S0x-5200-yy	D7	5	GR35C 400 V / 690 V

y = voltage class

### Fan Data for DCS800

Fan	CN2B2		W2E200		W2E 200		W2E 250		W2E 250	
Rated voltage [V]	115; 1~		230; 1~		115; 1~		115; 1~		230; 1~	
Tolerance [%]	±10		+6/-10		+6/-10		±10		+6/-10	
Frequency [Hz]	50	60	50	60	50	60	50	60	50	60
Power consumption [W]	16	13	64	80	64	80	120	165	135	185
Current consumpt. [A]	0.2	0.17	0.29	0.35	0.6	0.7	1.06	1.44	0.59	0.82
Blocking current [A]	< 0.3	< 0.26	< 0.7	< 0.8	< 1.5	< 1.8	< 1.8	< 1.8	< 0.9	< 0.9
Air flow [m3/h] freely blowing	156	180	925	1030	925	1030	1835	1940	1860	1975
Air flow [m3/h] at working point	-		-		-		-		-	
Max. ambient temperature [° C]	< 60		< 75		< 75		60		60	
Useful lifetime of grease	appr. 40000 h/60°		appr. 45000 h/60°		appr. 45000h/60°		appr. 40000 h		appr. 40000 h	
Protection	Impedance ①		Temperature detector: internal connected							
① Increased losses due to increased current with a blocked rotor will not result in a winding temperature, higher than permissible for the insulation class being involved.										

Fan	D2E 160		GR31M 380... 500 V		GR31M 525... 690 V		GR35C 400 / 690 V	
Rated voltage [V]	230; 1~		400...450 Δ 450...500 λ	400...500 Δλ	500...690 λ	500...690 λ 500 Δ	400..460 Δ 600...690 λ	
Tolerance [%]	±10		±10		±10		+5/-10	±10
Frequency [Hz]	50	60	50	60	50	60	50	60
Power consumption [W]	653	860	800 Δ 700 λ	1340 Δ	800 λ	1200 λ	2900 Δ 2200 λ	3600 Δ 3300 λ
Current consumpt. [A]	2.50	3.4	1.45 Δ 0.91 λ	2.0 Δ	0.9 λ	1.2 λ	6.5 Δ 2.3 λ	4.9 Δ 3.0 λ
Blocking current [A]	3.75	4.5	at 450 V Δ 8.5	at 500 V Δ 8.5	at 690 V λ	at 500 V Δ 8.5	at 400 V Δ >25	at 400 V Δ >30
Air flow [m3/h] freely blowing	-		-		-		-	
Air flow [m3/h] at working point	800 2.5 A	750 3.2 A	1500 1.26 A (450V Δ)	1600 1.6 A (500V Δ)	1500 0.7 A (690V λ)	1600 1.65 A (500V Δ)	4200 3.6 A (400V Δ)	4250 4.1 A (400V Δ)
Max. ambient temperature [° C]	< 55							
Useful lifetime of grease	appr. 30000 h/40°							
Protection	Temperatur detector: $U_N \leq 230 V \sim$ ; $I_N \leq 2.5 A \sim$							

\* 460 V < Supply < 600 V autotransformer strongly recommended, energy saving 20000 kWh/a

### Fan connection for DCS800

----- Terminals on top of converter housing -----

■ Converter housing

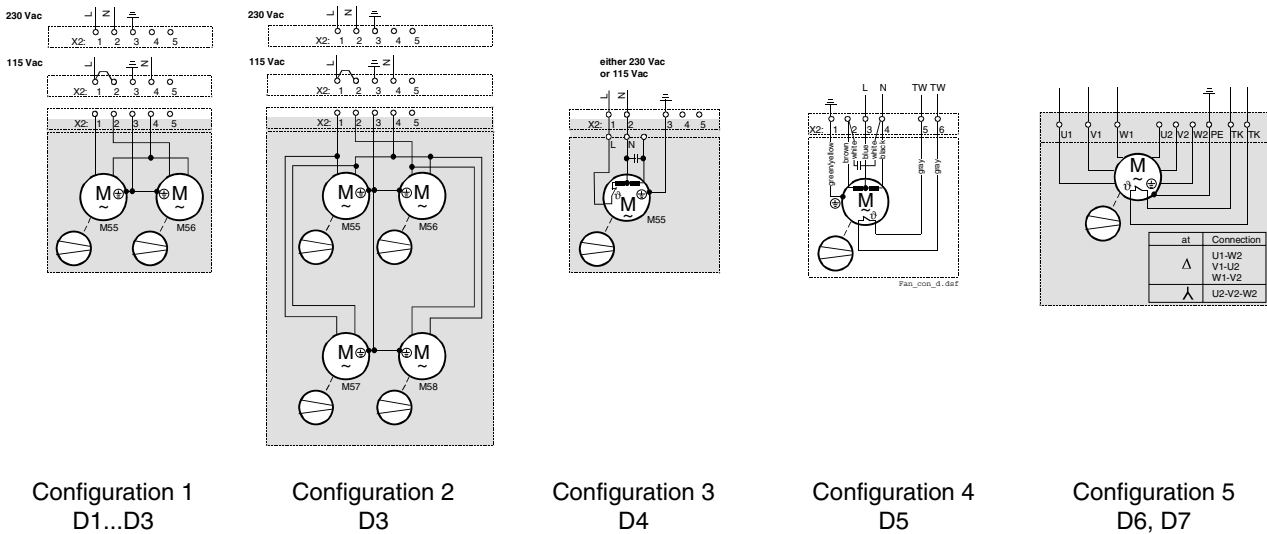

### Monitoring the DCS800 power section

a. The size D1...D5 power section is likewise monitored by an electrically isolated PTC thermistor detector, which is installed on the heat sink in an isolated configuration. Evaluation of the resistance and the protection effect correspond to max. temperature of type code.

b. The size D6 and D7 power section isolated PTC thermistor is used for air entry temperature. The detector thus measures the power section's radiated heat and any



changes in the cooling air temperature and volume. Since the cooling air volume can only be detected indirectly, a differential-pressure switch has been additionally installed at the unit's housing, always located close to the power terminals.

The resistance change proportional to the temperature is acquired and evaluated in the unit's software. If the temperature rises above the preset value, then first an alarm will be signaled, and - if the temperature continues to rise - an error message. The value to be set for this parameter must not be more than 5 degrees above the permissible ambient temperature.

The differential-pressure switch compares the pressure inside the unit with the normal atmospheric pressure. If the fan has been switched on and the unit door closed (and no unit casings have been removed), the pressure switch will signal "Cooling conditions ok", which means the drive may be enabled. There is no need to set any specific differential pressure (recommendation: center setting).

## **Thermal overload and short-circuit protection**

The drive protects itself and the input and motor cables against thermal overload when the cables are dimensioned according to the nominal current of the drive.

### **Mains cable (AC line cable) short-circuit protection**







Always protect the input cable with fuses. Size the fuses according to local safety regulations, appropriate input voltage and the rated current of the drive (see chapter *Technical Data*).

High-speed semiconductor fuses provide short-circuit protection, but don't provide thermal overload protection.

## Cross-sectional areas - Tightening torques

**Recommended** cross-sectional area to **DIN VDE 0276-1000** and **DIN VDE 0100-540 (PE)** trefoil arrangement, up to 50°C ambient temperature. The necessary wire torque at 60°C wire temperature is the same as recommended in the following tables.

### Armature:

Converter type	C1, D1 (AM1, KM1)		U1, V1, W1(AK1, AK3, AK5)			PE			
	IDC [A-]	1  [mm <sup>2</sup> ]	(2.)  [mm <sup>2</sup> ]	Iv [A~]	1  [mm <sup>2</sup> ]	(2.)  [mm <sup>2</sup> ]	 [mm <sup>2</sup> ]		
DCS800-S0x-0025-xx	25	1 x 6	-	41	1 x 4	-	1x 4	1 x M6	6
DCS800-S0x-0050-xx	50	1 x 10	-	41	1 x 6	-	1x 6	1 x M6	6
DCS800-S0x-0075-xx	75	1 x 25	-	61	1 x 25	-	1x 16	1 x M6	6
DCS800-S0x-0100-xx	100	1 x 25	-	82	1 x 25	-	1x 16	1 x M6	6
DCS800-S0x-0140-xx	140	1 x 35	-	114	1 x 35	-	1x 16	1 x M6	6
DCS800-S0x-0200-xx	200	2 x 35	1 x 95	163	2 x 25	1 x 95	1x 25	1 x M10	25
DCS800-S0x-0260-xx	260	2 x 35	1 x 95	204	2 x 25	1 x 95	1x 25	1 x M10	25
DCS800-S0x-0320-xx	320	2 x 70	1 x 95	220	2 x 50	1 x 95	1x 50	1 x M10	25
DCS800-S0x-0350-xx	350	2 x 70	-	286	2 x 50	-	1x 50	1 x M10	25
DCS800-S0x-0450-xx	450	2 x 95	-	367	2 x 95	-	1x 50	1 x M10	25
DCS800-S0x-0520-xx	520	2 x 95	-	424	2 x 95	-	1x 50	1 x M10	25
DCS800-S0x-0650-xx	650	2 x 120	-	555	2 x 120	-	1x120	1 x M12	50
DCS800-S0x-0680-xx	680	2 x 120	-	555	2 x 120	-	1x120	1 x M12	50
DCS800-S0x-0820-xx	820	2 x 150	-	669	2 x 120	-	1x120	1 x M12	50
DCS800-S0x-0900-6/7	900	4 x 95	3 x 150	734	4 x 70	3 x 95	1x150	2 x M12	50
DCS800-S0x-1000-xx	1000	2 x 185	-	816	2 x 150	-	1x150	1 x M12	50
DCS800-S0x-1200-xx	1200	4 x 120	-	979	4 x 95	3 x 120	1x185	2 x M12	50
DCS800-S0x-1500-xx	1500	4 x 185	-	1224	4 x 150	-	2x150	2 x M12	50
DCS800-S0x-2000-xx	2000	8 x 120	6 x 185	1632	4 x 240	-	2x240	2 x M12	50
DCS800-S0x-1900-xx ②	1900	8 x 120	6 x 185	1550	4 x 240	-	3x120	4 x M12	50
DCS800-S0x-2050-xx ②	2050	8 x 120	6 x 185	1673	6 x 120	5 x 150	3x120	4 x M12	50
DCS800-S0x-2500-xx ②	2500	7 x 185	-	2040	8 x 120	6 x 185	4x120	4 x M12	50
DCS800-S0x-2600-xx	2600	7 x 185	-	2122	8 x 120	6 x 185	4x120	4 x M12	50
DCS800-S0x-3000-xx ②	3000	8 x 185	-	2448	7 x 185	-	4x150	4 x M12	50
DCS800-S0x-3300-xx	3300	8 x 185	-	2693	7 x 185	-	4x150	4 x M12	50
DCS800-S0x-4000-xx	4000	7 x 300	-	3264	8 x 240	-	4x240	4 x M12	50
DCS800-S0x-4800-xx ①	4800	8 x 300	-	3876	6 x 300	-	3x300	4 x M12	50
DCS800-S0x-5200-xx ①	5200	8 x 300	-	4202	6 x 300	-	3x300	4 x M12	50

①Reduced ambient temperature 40°C

②Option for more flexible cable connection available

You will find instructions on how to calculate the PE conductor's cross-sectional area in VDE 0100 or in equivalent national standards. We would remind you that power converters may have a current-limiting effect.

### Excitation:

Size	D1	D2	D3	D4	D5	DCF803-0035
DC output current	6 A	15 A	20 A	25 A	25 A	35 A
max. cross sectional area	6 mm <sup>2</sup> / AWG 10	6 mm <sup>2</sup> / AWG 10	6 mm <sup>2</sup> / AWG 10	6 mm <sup>2</sup> / AWG 10	6 mm <sup>2</sup> / AWG 10	6 mm <sup>2</sup> / AWG 10
min. cross sectional area	1 mm <sup>2</sup> / AWG 16	2.5 mm <sup>2</sup> / AWG 13	4 mm <sup>2</sup> / AWG 11	6 mm <sup>2</sup> / AWG 10	6 mm <sup>2</sup> / AWG 10	6 mm <sup>2</sup> / AWG 10
Tightening torque	1.5...1.7 Nm					

## Typical Cable Sizing and Tightening Torque – North America

Based on NEC Table 310.16. No more than 3 current carrying conductors per raceway.

Maximum Ambient Temperature - 40C

Conductor Temperature Rating - 75C (except where noted)

Converter Type	C1, D1		U1, V1, W1		PE	Tightening Torque	
	Output		Input		Ground	Terminal Size	Torque (ft-lb)
	IDC	Typical Cable	IAC	Typical Cable	Minimum Cable <sup>②</sup>		
DCS800-S0x-0020-xx	20	10 AWG	16	10 AWG	10 AWG	1 x M6	5
DCS800-S0x-0025-xx	25	8 AWG	20	10 AWG	10 AWG	1 x M6	5
DCS800-S0x-0045-xx	45	6 AWG	37	6 AWG	10 AWG	1 x M6	5
DCS800-S0x-0050-xx	50	4 AWG	41	6 AWG	10 AWG	1 x M6	5
DCS800-S0x-0065-xx	65	2 AWG	53	4 AWG	8 AWG	1 x M6	5
DCS800-S0x-0075-xx	75	2 AWG	61	2 AWG	8 AWG	1 x M6	5
DCS800-S0x-0090-xx	90	1 AWG	73	2 AWG	8 AWG	1 x M6	5
DCS800-S0x-0100-xx	100	1/0 AWG	82	1 AWG	6 AWG	1 x M6	5
DCS800-S0x-0125-xx	125	3/0 AWG	102	1/0 AWG	6 AWG	1 x M6	5
DCS800-S0x-0140-xx	140	3/0 AWG	114	2/0 AWG	6 AWG	1 x M6	5
DCS800-S0x-0180-xx	180	300 MCM	147	4/0 AWG	6 AWG	1 x M10	18
DCS800-S0x-0200-xx	200	300 MCM	163	250 MCM	4 AWG	1 x M10	18
DCS800-S0x-0230-xx	230	400 MCM	188	300 MCM	4 AWG	1 x M10	18
DCS800-S0x-0260-xx	260	500 MCM	212	350 MCM	4 AWG	1 x M10	18
DCS800-S0x-0290-xx	290	2 x 4/0 AWG	237	500 MCM	4 AWG	1 x M10	18
DCS800-S0x-0315-xx	315	2 x 4/0 AWG	257	500 MCM	2 AWG	1 x M10	18
DCS800-S0x-0320-xx	320	2 x 4/0 AWG	261	500 MCM	2 AWG	1 x M10	18
DCS800-S0x-0350-xx	350	2 x 250 MCM	286	2 x 4/0 AWG	2 AWG	1 x M10	18
DCS800-S0x-0405-xx	405	2 x 350 MCM	330	2 x 250 MCM	2 AWG	1 x M10	18
DCS800-S0x-0450-xx	450	2 x 400 MCM	367	2 x 300 MCM	2 AWG	1 x M10	18
DCS800-S0x-0470-xx	470	2 x 400 MCM	384	2 x 300 MCM	2 AWG	1 x M10	18
DCS800-S0x-0520-xx	520	2 x 500 MCM	424	2 x 350 MCM	1 AWG	1 x M10	18
DCS800-S0x-0590-xx	590	3 x 300 MCM	481	2 x 500 MCM	1/0 AWG	1 x M12	37
DCS800-S0x-0610-xx	610	3 x 350 MCM	498	2 x 500 MCM	1/0 AWG	1 x M12	37
DCS800-S0x-0650-xx	650	3 x 350 MCM	530	2 x 500 MCM	1/0 AWG	1 x M12	37
DCS800-S0x-0680-xx	680	3 x 400 MCM	555	3 x 300 MCM	1/0 AWG	1 x M12	37
DCS800-S0x-0740-xx	740	3 x 500 MCM	604	3 x 350 MCM	1/0 AWG	1 x M12	37
DCS800-S0x-0820-xx	820	4 x 350 MCM	669	3 x 400 MCM	2/0 AWG	2 x M12	37
DCS800-S0x-0900-xx	900	4 x 400 MCM	734	3 x 500 MCM	2/0 AWG	2 x M12	37
DCS800-S0x-1000-xx	1000	4 x 500 MCM	816	4 x 350 MCM	3/0 AWG	2 x M12	37
DCS800-S0x-1200-xx	1200	5 x 500 MCM	979	4 x 500 MCM	4/0 AWG	4 x M12	37
DCS800-S0x-1500-xx	1500	6 x 500 MCM	1224	5 x 500 MCM	4/0 AWG	4 x M12	37
DCS800-S0x-2000-xx	2000	8 x 500 MCM	1632	7 x 400 MCM	350 MCM	4 x M12	37
DCS800-S0x-2050-xx	2050	8 x 500 MCM	1673	7 x 500 MCM	350 MCM	4 x M12	37
DCS800-S0x-2500-xx <sup>①</sup>	2500	8 x 500 MCM	2040	7 x 500 MCM	400 MCM	4 x M12	37
DCS800-S0x-3000-xx <sup>①</sup>	3000	8 x 700 MCM	2448	8 x 500 MCM	500 MCM	4 x M12	37
DCS800-S0x-3300-xx <sup>①</sup>	3300	8 x 900 MCM	2693	8 x 600 MCM	500 MCM	4 x M12	37
DCS800-S0x-4000-xx <sup>①</sup>	4000	9 x 1000 MCM	3264	8 x 900 MCM	700 MCM	4 x M12	37
DCS800-S0x-4800-xx <sup>①</sup>	4800	11 x 1000 MCM	3917	9 x 1000 MCM	700 MCM	4 x M12	37
DCS800-S0x-5200-xx <sup>①</sup>	5200	12 x 1000 MCM	4243	10 x 900 MCM	800 MCM	4 x M12	37

① Use wire rated for 90C ambient temperature

② The minimum ground cable recommendation assumes that the overcurrent protection for each drive is selected to provide protection at 125% of the rated drive input current. If the overcurrent protection (e.g. circuit breaker) is sized larger than this, then larger ground cables will need to be determined manually.

## Selecting the control cables

All control cables except 220 V or 115 V must be shielded.

Use a double-shielded twisted pair cable (Figure a, e.g. JAMAK by NK Cables, Finland or BELDEN type, USA) for analogue signals. This type of cable is recommended for the pulse encoder signals also. Employ one individually shielded pair for each signal. Do not use common return for different analogue signals.

A double-shielded cable is the best alternative for low-voltage digital signals but single-shielded twisted multipair cable (Figure b) is also usable.

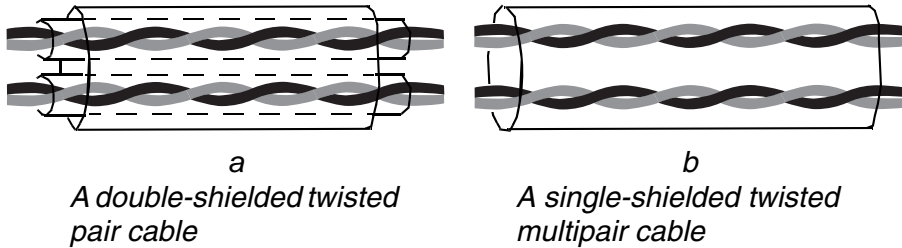

Run analogue and digital signals in separate, shielded cables.

Relay-controlled signals, providing their voltage does not exceed 48 V, can be run in the same cables as digital input signals. It is recommended that the relay-controlled signals be run as twisted pairs.

**! Never mix 24 VDC and 115/230 VAC signals in the same cable.**

### DCS800 panel cable

The cable connection of the DCS800 panel to the drive must not exceed 3 meters (10 ft). The cable type tested and approved by ABB is used in control panel option kits.

## Connection of a motor temperature sensor to the drive I/O

---



**WARNING!** IEC 60664 requires double or reinforced insulation between live parts and the surface of accessible parts of electrical equipment which are either non-conductive or conductive but not connected to the protective earth.

To fulfill this requirement, the connection of a thermistor (and other similar components) to the inputs of the drive can be implemented by three alternate ways:

1. There is double or reinforced insulation between the thermistor and live parts of the motor.
  2. Circuits connected to all digital and analogue inputs of the drive are protected against contact and insulated with basic insulation (the same voltage level as the drive main circuit) from other low voltage circuits.
  3. An external thermistor relay is used. The insulation of the relay must be rated for the same voltage level as the main circuit of the drive.
-



# Electrical installation

---

## What this chapter contains

This chapter describes the electrical installation procedure of the drive.



**WARNING!** The work described in this chapter may only be carried out by a qualified electrician. Follow the [Safety instructions](#) on the first pages of this manual. Ignoring the safety instructions can cause injury or death.

**Make sure that the drive is disconnected from the mains (input power) during installation. If the drive was already connected to the mains, wait for 5 min. after disconnecting mains power.**

**Reference:** *Technical Guide* - publ. no.: 3ADW000163

## Checking the insulation of the assembly

Every drive has been tested for insulation between the main circuit and the chassis (2500 V rms 50 Hz for 1 second) at the factory. Therefore, do not make any voltage tolerance or insulation resistance tests (e.g. hi-pot or megger) on any part of the drive. Check the insulation of the assembly as follows.



**WARNING!** Check the insulation before connecting the drive to the mains. Make sure that the drive is disconnected from the mains (input power).

1. Check that the motor cable is disconnected from the drive output terminals C1, D1, F+ and F-.
2. Measure the insulation resistances of the motor cable and the motor between each circuit (C1, D1) or (F+, F-) and the Protective Earth by using a measuring voltage of 1 kV DC. The insulation resistance must be higher than 1 Mohm.

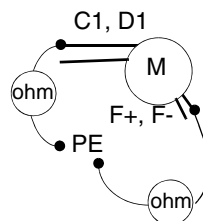

## IT (ungrounded) systems

Don't use EMC filters.

The screen winding of dedicated transformers must be grounded.

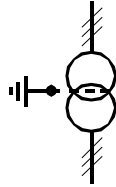

For installation without low voltage switch (e.g. contactor, air-circuit-breaker) use overvoltage protection.

The voltage shift of the isolated supply must not be larger than the voltage shift in case on an earth fault.

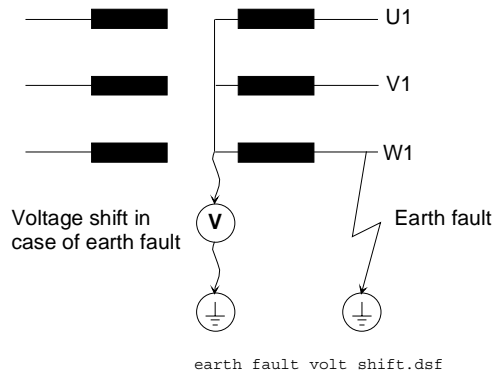

## Supply voltage

Check supply voltages of:

Aux	X99
Fan	Terminals
AC voltage for field circuit	U1, V1, W1 (if used)
AC voltage for armature circuit	U1, V1, W1

## Connecting the power cables

Grounding and screening of power cables see manual *Technical Guide*, see *Reference*

Cross sectional areas and tightening torques of power cable see chapter *Planning the electrical installation*



## Location R-Extension and Interface Modules

Connect the signal cables as described below. Tighten the screws to secure the extension modules.

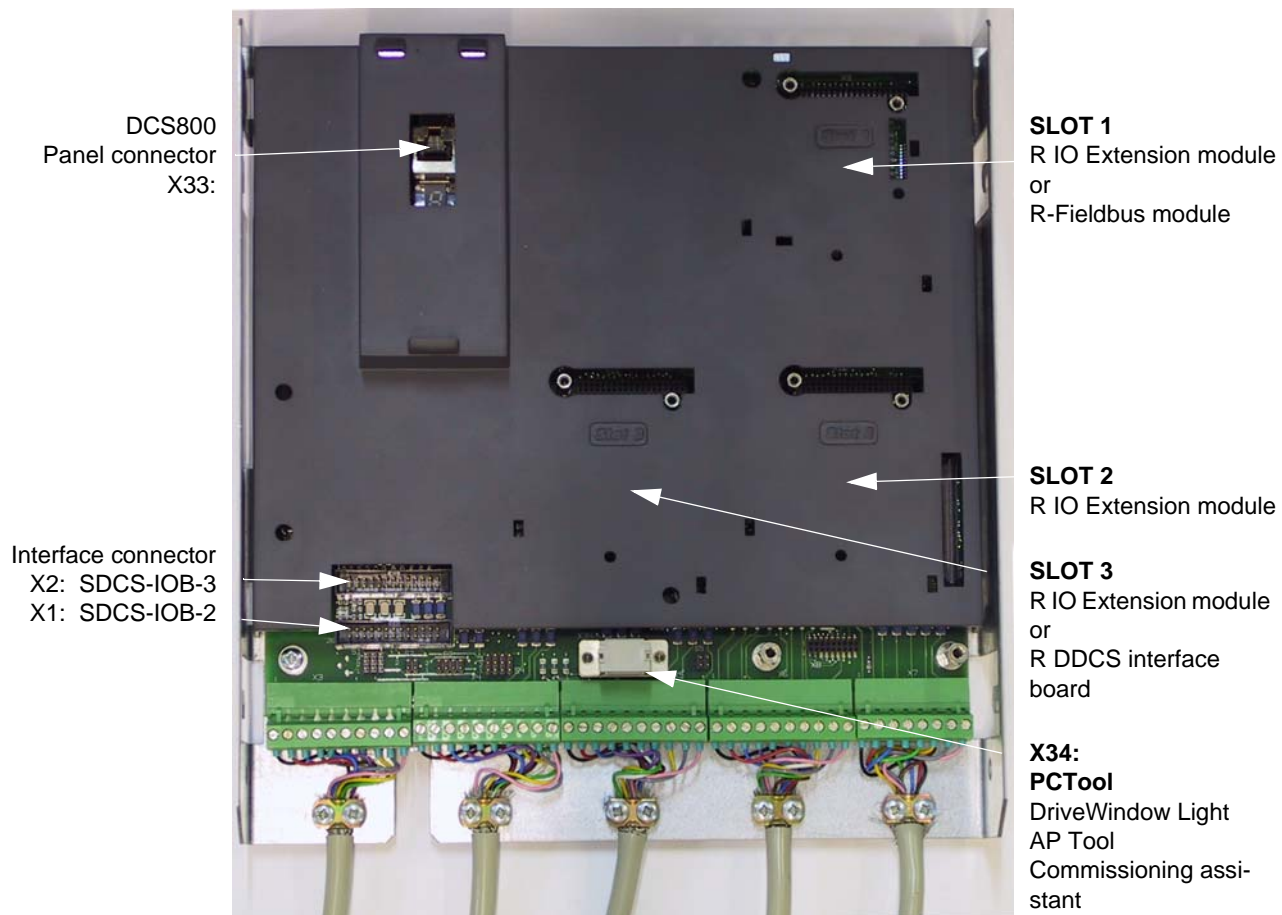

## I/O Board Configuration

### In-/output signals

The converter can be connected in four different ways to a control unit via analogue/digital signals. Only one of the four choices can be used at the same time.

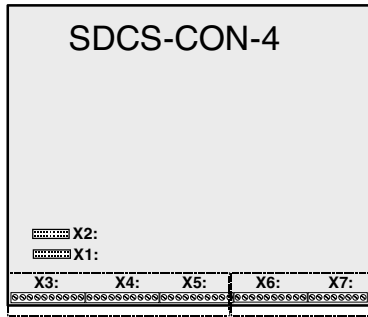

#### I/O's via SDCS-CON-4

**Analogue I/O's:** standard  
**Digital I/O's:** not isolated  
**Encoder input:** not isolated

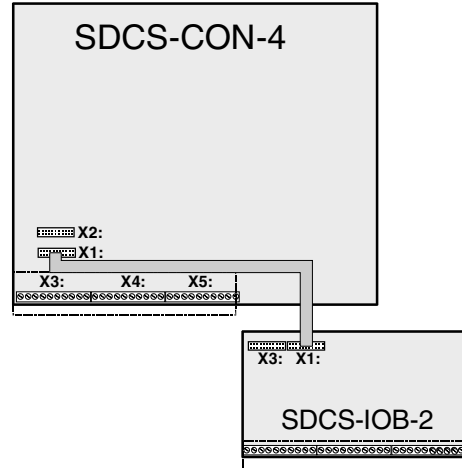

#### I/O's via SDCS-CON-4 and SDCS-IOB-2

**Analogue I/O's:** standard  
**digital I/O's:** all isolated by means of optocoupler/relay, the signal status is indicated by LED

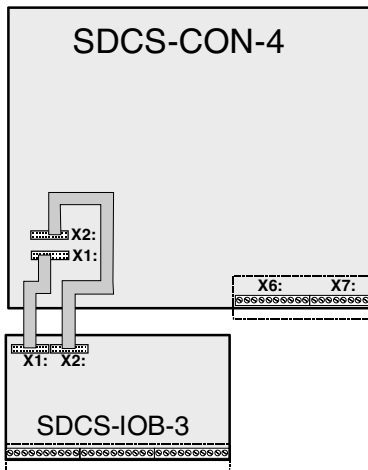

#### I/O's via SDCS-CON-4 and SDCS-IOB-3

**Analogue I/O's:** Standard + one channel for residual current measurement  
**digital I/O's:** not isolated  
**encoder input:** isolated  
**current source for:** PT100/PTC element

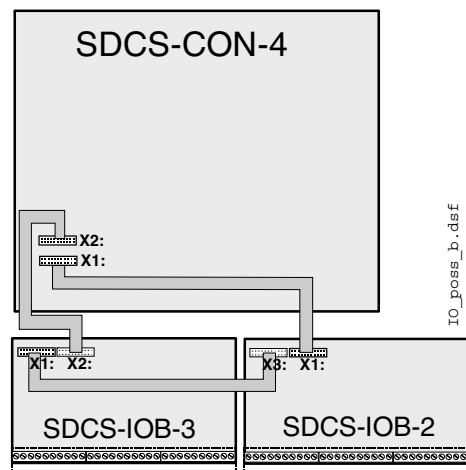

#### I/O's via SDCS-IOB-2 and SDCS-IOB-3

**Analogue I/O's:** Standard + one channel for residual current measurement  
**digital I/O's:** all isolated by means of optocoupler/relay, the signal status is indicated by LED  
**current source for:** PT100/PTC element

## Pulse encoder connection

### Connecting a pulse encoder to the DCS800 converter

The connection diagram for a pulse encoder to the electronics of a DCS converter is quite similar, if the SDCS-CON-4 or the SDCS-IOB-3 is used. The basic difference between these 2 boards is the galvanically isolated circuit and pulse receivers via opto coupler on the SDCS-IOB-3 board.

### Power supply for incremental encoder

SDCS-CON-4 and SDCS-IOB-3 board have jumpers to select a supply voltage. V17 LED on SDCS-IOB-3 indicates supply is OK.

Encoder supply	Hardware configuration		
	SDCS-CON-4 supplied by PIN-4	SDCS-CON-4 supplied by POW-1/POW-4	SDCS-IOB-3
5 V	sense controlled	sense controlled	sense controlled
12 V	-	no sense	sense controlled
24 V	no sense	no sense	no sense

Sense feedback connection is recommended when power supply level for differential pulse encoder is 5 V. The wiring is shown on figure below.

### Commissioning hint

#### Note:

If the drive's measured direction of rotation is wrong or does not correspond to measured EMF speed, the **SPEEDFB** fault may appear during start-up. If necessary correct by exchanging the field connection

If with a positive reference the position signal 3.07 or 3.08 signal does not look like the illustration below, then tracks A &  $\bar{A}$  must be exchanged with inverted signals. For single-ended encoders Tracks A and B must be exchanged.

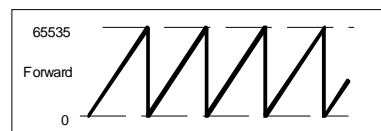
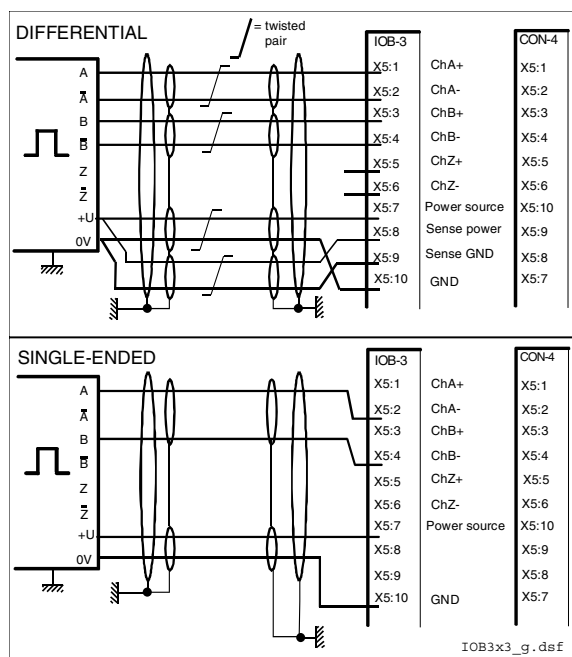

## Pulse encoder receiver

Two different incremental encoder connections are available.

- differential connection; pulse encoders generating either voltage or current signals can be used

- single-ended (push pull) connection; voltage signals

Restrictions using jumper S4 (CON-4): or S10 (IOB-3): depending on the board

Line termination via S4/S10 should not be used at 12 V or 24 V encoders, because of the power consumption taken from the encoder. If a pulse encoder with a build in current source is used a burden resistor of 120 Ω is activated via jumper S10: 1-2 on SDCS-IOB-3 a.s.o.

Pulse encoder connection principles

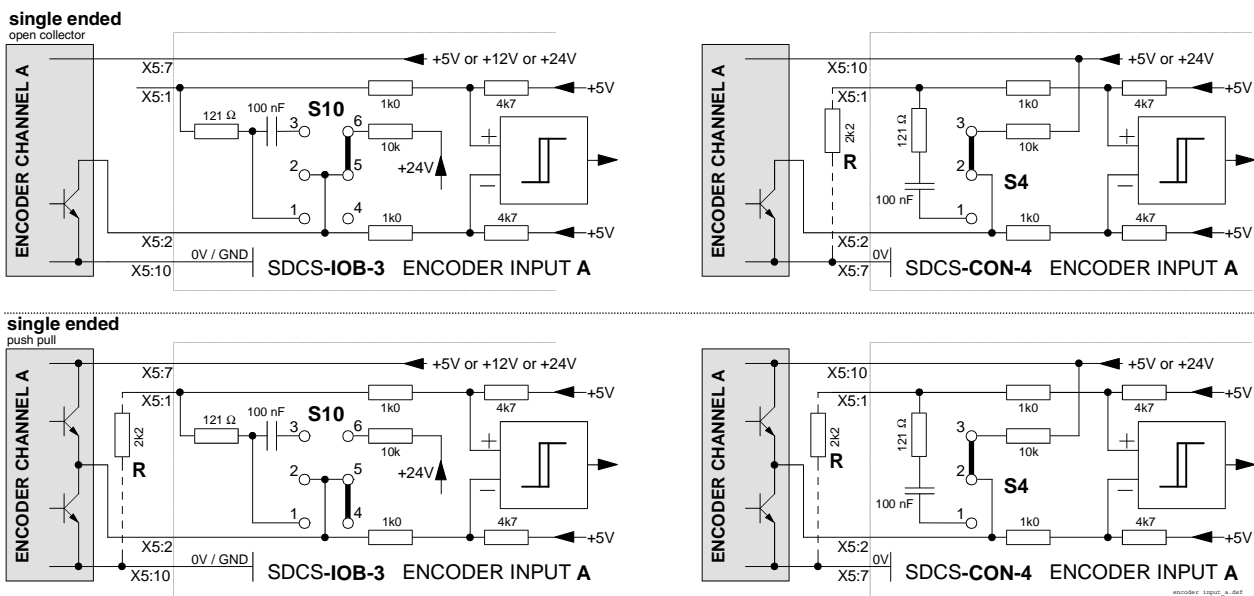

In case of a single ended 5 V encoder the jumpers S4 / S10 will be set to a neutral position. To get a threshold lower than 5 V each terminal X5:2 / X5:4 / X5:6 must be connected via a resistor R to GND.

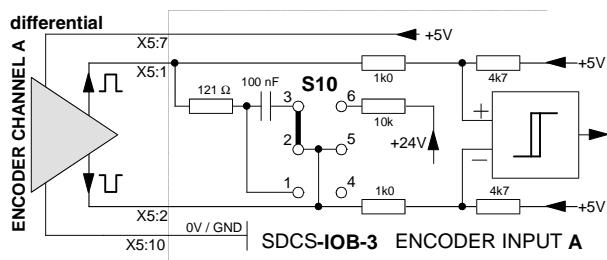

	CON-4		IOB-3	
	5 V	12/24 V	5 V	12/24 V
<b>differential voltage source</b>	<b>S4</b> 1-2 4-5 7-8	<b>S4</b> 3=park 6=park 9=park	<b>S10</b> 2-3 8-9 14-15	<b>S10</b> 4-5 10-11 16-17
<b>differential current source</b>	-	-	<b>S10</b> 1-2 7-8 13-14	-

**In any case, if SDCS-IOB-3 is used, see required settings of SDCS-CON-4 board**

The maximum distance between pulse encoder and interface board is dependent on the voltage drop on the connecting lines and on the output and input configuration of the used components. If cables are used according to the table below the voltage drop caused by the cable can be compensated by the voltage regulator.

Cable length	parallel wires for power source & GND	Cable used
0 ... 50 m	1x 0.25 mm <sup>2</sup>	12x 0.25 mm <sup>2</sup>
50 ... 100 m	2x 0.25 mm <sup>2</sup>	12x 0.25 mm <sup>2</sup>
100 ... 150 m	3x 0.25 mm <sup>2</sup>	14x 0.25 mm <sup>2</sup>

Use twisted pair cable with pair shielding plus overall shielding.

Cable length	parallel wires for power source & GND	Cable used
0 to 164 ft	1 x 24 AWG	12 x 24 AWG
164 to 328 ft	2 x 24 AWG	12 x 24 AWG
328 to 492 ft	3 x 24 AWG	14 x 24 AWG

## Connecting the signal and control cables

The cables for digital signals, which are longer than 3 m and all cables for analogue signals, must be screened. Each screen must be connected at both ends by metal clamps or comparable means directly on clean metal surfaces, if both earthing points belong to the same earth line. Otherwise a capacitor must be connected to earth on one end. In the converter cubicle this kind of connection must be made directly on the sheet metal as close as possible to the terminals and if the cable comes from outside also on the PE bar. At the other end of the cable the screen must be well connected with the housing of the signal emitter or receiver.

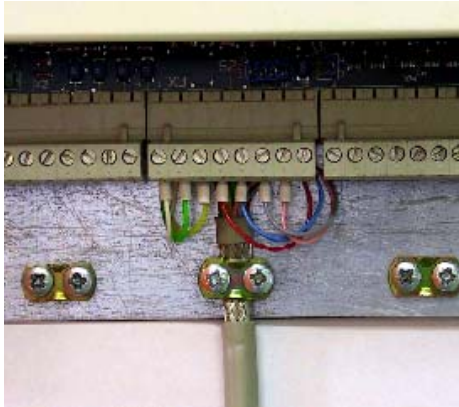

Connection of a cable screen with the aid of metal clamp to the metal surface of the PCB carrier at a DCS converter

Size D6, D7  
Screen connection



## Routing the cables

Route the motor cable away from other cable routes. Motor cables of several drives can be run in parallel installed next to each other. It is recommended that the motor cable, input power cable and control cables be installed on separate trays. Avoid long parallel runs of motor cables with other cables in order to decrease electromagnetic interference caused by the rapid changes in the drive output voltage.

Where control cables must cross power cables make sure they are arranged at an angle as near to 90 degrees as possible. Do not run extra cables through the drive.

The cable trays must have good electrical bonding to each other and to the grounding electrodes. Aluminium tray systems can be used to improve local equalizing of potential.

A diagram of the cable routing is shown below.

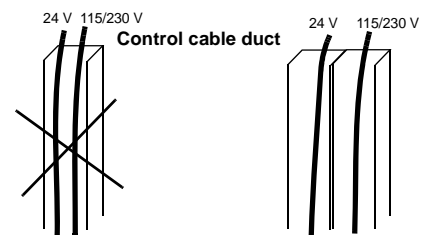
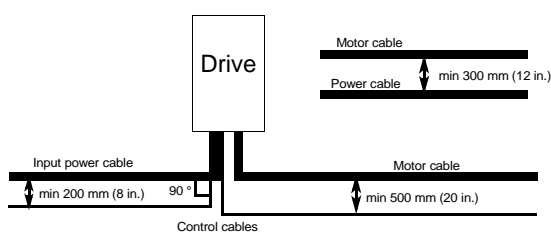

Not allowed unless the 24 V cable is insulated for 230 V or insulated with an insulation sleeving for 115/230 V.

Lead 24 V and 115/230 V control cables in separate ducts inside the cabinet.

## DCS Link Wiring

DCS Link is a 500 Kbaud serial communication between:

- Drive to drive or
- Drive to Field exciter

based on CAN hardware and twisted pair cabling.

The topology of the bus must be: **Bus**

Switched OFF nodes can remain in the bus and do not disturb the serial communication.

The function of the interface is predefined:

- 1 Mailbox function for peer to peer communication
- 2 Communication to field exciter DCF 804, DCF803 and three-phase field supply of DCS800
- 3 Communication for 12-pulse operation, DCS800 to DCS800

### Cabling

Every bus node requires the setting of Node number.

The bus termination of twisted pair cable is performed with a pre-designed termination resistor 120 Ohm inside Drive / field exciter.

The termination resistance of 120 Ohm is selected for typical twisted pair cable. It must be located in both ends and activated by jumper or switch.

Preferred cable type: DEVICENET

Supplier: Helu Kabel, Germany; type 81910PUR

Belden, USA; type 3084A

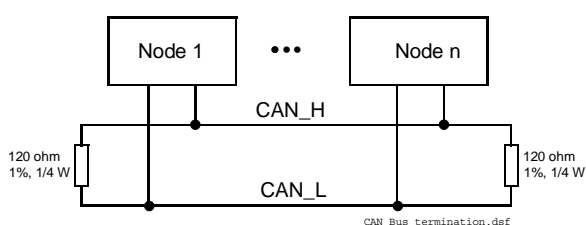

The bus ground (GNDB) is isolated. It can be ground terminated at one point only.

Example of two DCS800 D5 converters with FEX-425-Int internal field supply.

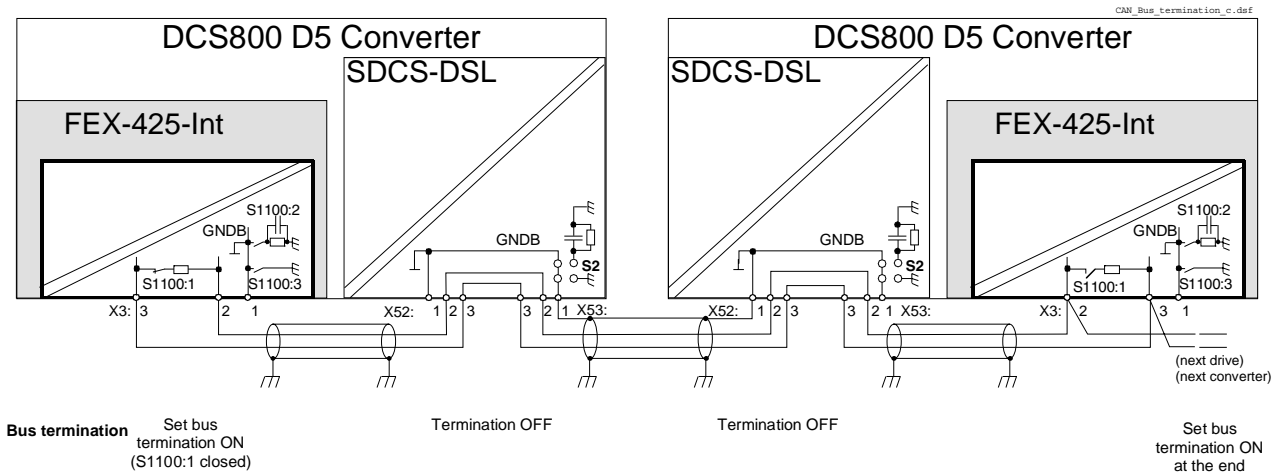

The connection of isolated GNDB between two or more serial communication interfaces is optional. It is recommended to connect GNDB if the supply voltage is above 690 V and the cabling is made from cubicle to cubicle.

Example of one DCS800 D5 converter plus external field supply.

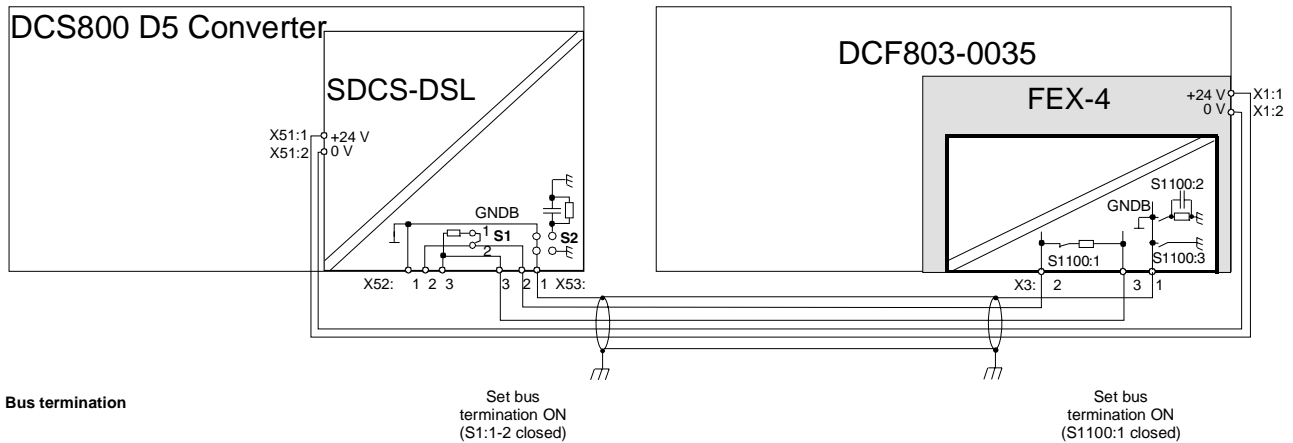

### Cable length

The cable length influences the maximum baudrate.

Baudrate	max. cable length
50 k	500 m
125 k	500 m
250 k	250 m
500 k	100 m
800 k	50 m
888 k	35 m
1000 k	25 m

default and recommended setting

The bus is designed for cable length up to 50 meters. Larger distances on request.



# Installation checklist

---

## Checklist

Check the mechanical and electrical installation of the drive before start-up. Go through the checklist below together with another person. Read the [Safety instructions](#) on the first pages of this manual before you work on the unit.

Check
<p><b>MECHANICAL INSTALLATION</b></p> <ul style="list-style-type: none"> <li><input type="checkbox"/> The ambient operating conditions are allowed. (See <a href="#">Mechanical installation, current ratings Ambient conditions</a>.)</li> <li><input type="checkbox"/> The unit is fixed properly on a vertical non-flammable wall. (See <a href="#">Mechanical installation</a>.)</li> <li><input type="checkbox"/> The cooling air will flow freely.</li> <li><input type="checkbox"/> The motor and the driven equipment are ready for start. (See <a href="#">Planning the electrical installation</a>)</li> <li><input type="checkbox"/> All screen terminals are checked for tightness.</li> <li><input type="checkbox"/> All cable connections are seated properly.</li> </ul> <p><b>ELECTRICAL INSTALLATION</b> (See <a href="#">Planning the electrical installation, Electrical installation</a>.)</p> <ul style="list-style-type: none"> <li><input type="checkbox"/> The drive is grounded properly.</li> <li><input type="checkbox"/> The mains (input power) voltage matches the drive nominal input voltage.</li> <li><input type="checkbox"/> The mains (input power) connections at U1, V1 and W1 and their tightening torques are OK.</li> <li><input type="checkbox"/> Appropriate mains (input power) fuses and disconnectors are installed.</li> <li><input type="checkbox"/> The motor connections at C1, D1 and F+, F- and their tightening torques are OK.</li> <li><input type="checkbox"/> Proper function of E_Stop circuit and relay.</li> <li><input type="checkbox"/> Fan power wiring connected.</li> <li><input type="checkbox"/> The external control connections inside the drive are OK.</li> <li><input type="checkbox"/> There are no tools, foreign objects or dust from drilling inside the drive.</li> <li><input type="checkbox"/> Drive, motor connection box and other covers are in place.</li> </ul>



# Maintenance

---

## What this chapter contains

This chapter contains preventive maintenance instructions.

**Reference:** *Service manual* - publ. no.: 3ADW000195

## Safety



**WARNING!** Read the [Safety instructions](#) on the first pages of this manual before performing any maintenance on the equipment. Ignoring the safety instructions can cause injury or death.

---

## Maintenance intervals

If installed in an appropriate environment, the drive requires very little maintenance. This table lists the routine maintenance intervals recommended by ABB.

Maintenance	Interval	Instruction
Heatsink temperature check and cleaning	Depends on the dustiness of the environment (every 6 to 12 months)	See <a href="#">Heatsink</a> .
Cooling fan change	Every six years	See <a href="#">Fan</a> .

## Heatsink

The heatsink fins pick up dust from the cooling air. The drive runs into overtemperature warnings and faults if the heatsink is not clean. In a “normal” environment (not dusty, not clean) the heatsink should be checked annually, in a dusty environment more often.

Clean the heatsink as follows (when necessary):

1. Remove the cooling fan (see section [Fan](#)).
2. Blow clean compressed air (not humid, no oil) from bottom to top and simultaneously use a vacuum cleaner at the air outlet to trap the dust. **Note:** If there is a risk of the dust entering adjoining equipment, perform the cleaning in another room.
3. Assemble back the cooling fan.

## Fan

The cooling fan lifespan of the drive is about 50 000 operating hours. The actual lifespan depends on the drive usage and ambient temperature.

Fan failure can be predicted by the increasing noise from fan bearings and the gradual rise in the heatsink temperature in spite of heatsink cleaning. If the drive is operated in a critical part of a process, fan replacement is recommended once these symptoms start appearing. Replacement fans are available from ABB. Do not use other than ABB specified spare parts.

### Fan replacement (D6, D7)

see *Service Manual*

# Technical data

## What this chapter contains

This chapter contains the technical specifications of the drive, e.g. the ratings, sizes and technical requirements, provisions for fulfilling the requirements for CE and other markings and warranty policy.

<b>Reference:</b>	<i>Hardware extension</i>	<i>RAIO Analog I/O Extension</i>	publ.no.:3AFE64484567
	<i>Hardware extension</i>	<i>RDIO Digital I/O Extension</i>	publ.no.:3AFE64485733
	<i>DCS800 1131 Programming target</i>		publ.no.:3ADW000199
	<i>Branching units NDBU-95</i>		publ.no.:3ADW000100

## Environmental Conditions

### System connection

Voltage, 3-phase:	230 to ≤1000 V acc. to IEC 60038
Voltage deviation:	±10% continuous; ±15% short-time *
Rated frequency:	50 Hz or 60 Hz
Static frequency deviation:	50 Hz ±2 %; 60 Hz ±2 %

Dynamic: frequency range:	50 Hz: ±5 Hz; 60 Hz: ± 5 Hz
df/dt:	17 % / s

\* = 0.5 to 30 cycles.

**Please note:** Special consideration must be taken for voltage deviation in regenerative mode.

### Degree of protection

Converter Module and options (line chokes, fuse holder,

field supply unit, etc.):	IP 00 / NEMA TYPE OPEN
Enclosed converters:	IP 20/21/31/41

### Paint finish

Converter module:	light grey RAL 9002
Enclosed converter:	light grey RAL 7035

### Environmental limit values

Permissible cooling air temp.	
- at converter module air inlet:	0 to +55°C
with rated DC current:	0 to +40°C
w. different DC curr. acc. Fig. below:	+30 to +55°C
- Options:	0 to +40°C
Relative humidity (at 5...+40°C):	5 to 95%, no condensation
Relative humidity (at 0...+5°C):	5 to 50%, no condensation
Change of the ambient temp.:	< 0.5°C / minute

Storage temperature:	-40 to +55°C
Transport temperature:	-40 to +70°C
Pollution degree (IEC 60664-1, IEC 60439-1):	2
Vibration class (IEC-60721-3-3)	3M3 - D1...D4 3M1 - D5...D7
Site elevation	
<1000 m above M.S.L.:	100%, without current reduction
>1000 m above M.S.L.:	with curr. reduct., see Fig. below

Size	Sound pressure level $L_p$ (1 m distance)		Vibration	Shock	Transport in original Package	Short circuit withstand rating The DCS800 is suitable for use in a circuit capable of delivering not more than:
	as module	enclosed conv.				
D1	55 dBA	54 dBA	1.5 mm, 2...9 Hz 0.5 g, 9...200 Hz	7 g / 22 ms	1.2 m	65 kA rms symmetrical amps at maximum 600 VAC
D2	55 dBA	55 dBA			0.25 m	
D3	60 dBA	73 dBA				
D4	66...70 dBA, depending on fan	77 dBA				
D5	73 dBA	78 dBA	0.3 mm, 2...9 Hz 0.1 g, 9...200 Hz	4 g / 22 ms	Shock monitor	100 kA rms symmetrical amps at maximum 600 VAC
D6	75 dBA	73 dBA				
D7	82 dBA	80 dBA				

Effect of the site elevation above sea level on the converter's load capacity

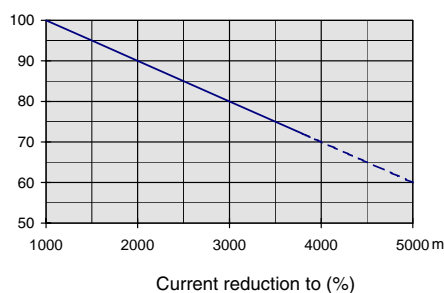

Effect of the ambient temperature on the converter module load capacity

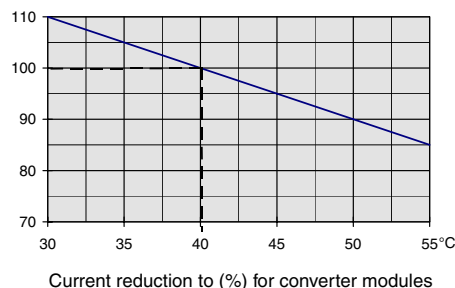

### Regulatory Compliance

The converter module and enclosed converter components are designed for use in industrial environments. In EEA countries, the components fulfil the requirements of the EU directives, see table below.

European Union Directive	Manufacturer's Assurance	Harmonized Standards	
		Converter module	Enclosed converter
<b>Machinery Directive</b>			
98/37/EEC 93/68/EEC	Declaration of Incorporation	EN 60204-1 [IEC 60204-1]	EN 60204-1 [IEC 60204-1]
<b>Low Voltage Directive</b>			
73/23/EEC 93/68/EEC	Declaration of Conformity	EN 61800-1 [IEC 61800-1] EN 60204-1 [IEC 60204-1]	EN 61800-1 [IEC 61800-1] EN 60204-1 [IEC 60204-1]
<b>EMC Directive</b>			
89/336/EEC 93/68/EEC	Declaration of Conformity  (Provided that all installation instructions concerning cable selection, cabling and EMC filters or dedicated transformer are followed.)	EN 61800-3 ① [IEC 61800-3]  ① in accordance with 3ADW 000 032	EN 61800-3 ① [IEC 61800-3]  ① in accordance with 3ADW 000 032/3ADW 000 091

### North American Standards

In North America the system components fulfil the requirements of the table below.

Rated supply voltage	Standards	
	Converter module	Enclosed converter
to 600 V	<ul style="list-style-type: none"> <li>• see UL Listing- www.ul.com / certificate no. E196914</li> <li>Approval: <sub>c</sub>UL<sub>us</sub> The spacings in the modules were evaluated to table 36.1 of UL 508 C. Spacings also comply with table 6 and table 40 of C22.2 No. 14-05.</li> <li>• or on request</li> </ul>	UL types: on request
>600 V to 990 V	EN / IEC xxxxx see table above. Available for converter modules including field exciter units.	EN / IEC types: on request (for details see table above)

## Current ratings - IEC non regenerative

The current ratings for the DCS800 with 50 Hz and 60 Hz supplies are given below. The symbols are described below the table.

Power converter module currents with corresponding load cycles.

The characteristics are based on an ambient temperature of max. 40°C and an elevation of max. 1000 m a.s.l.

Unit type	I <sub>DC I</sub>	I <sub>DC II</sub>		I <sub>DC III</sub>		I <sub>DC IV</sub>		Size	internal field curr.
		contin- ous	100 % 15 min	150 % 60 s	100 % 15 min	150 % 120 s	100 % 15 min		
<b>2-Q converters</b>									
<b>400 V / 525 V</b>	[A]	[A]		[A]		[A]			
DCS800-S01-0020-04/05	20	18	27	18	27	18	36	D1	6 A
DCS800-S01-0045-04/05	45	40	60	37	56	38	76		
DCS800-S01-0065-04/05	65	54	81	52	78	55	110		
DCS800-S01-0090-04/05	90	78	117	72	108	66	132		
DCS800-S01-0125-04/05	125	104	156	100	150	94	188		
DCS800-S01-0180-04/05	180	148	222	144	216	124	248	D2	15 A
DCS800-S01-0230-04/05	230	200	300	188	282	178	356	D3	20 A
DCS800-S01-0315-04/05	315	264	396	250	375	230	460		
DCS800-S01-0405-04/05	405	320	480	310	465	308	616		
DCS800-S01-0470-04/05	470	359	539	347	521	321	642	D4	25 A
DCS800-S01-0610-04/05	610	490	735	482	723	454	908		
DCS800-S01-0740-04/05	740	596	894	578	867	538	1076	D5	25 A * +S164
DCS800-S01-0900-04/05	900	700	1050	670	1005	620	1240		
DCS800-S01-1200-04/05	1200	888	1332	872	1308	764	1528	D6	-
DCS800-S01-1500-04/05	1500	1200	1800	1156	1734	1104	2208		
DCS800-S01-2000-04/05	2000	1479	2219	1421	2132	1361	2722	D7	-
DCS800-S01-2050-05	2050	1550	2325	1480	2220	1450	2900		
DCS800-S01-2500-04/05	2500	1980	2970	1880	2820	1920	3840	D7	-
DCS800-S01-3000-04/05	3000	2350	3525	2220	3330	2280	4560		
DCS800-S01-3300-04/05	3300	2416	3624	2300	3450	2277	4554	D7	-
DCS800-S01-4000-04/05	4000	2977	4466	2855	4283	2795	5590		
DCS800-S01-5200-04/05	5200	3800	5700	3669	5504	3733	7466		
<b>600 V / 690 V</b>									
DCS800-S01-0290-06	290	240	360	225	337	205	410	D3	-
DCS800-S01-0590-06	590	470	705	472	708	434	868	D4	-
DCS800-S01-0900-06/07	900	684	1026	670	1005	594	1188	D5	25 A * +S164
DCS800-S01-1500-06/07	1500	1200	1800	1104	1656	1104	2208		
DCS800-S01-2000-06/07	2000	1479	2219	1421	2132	1361	2722	D6	-
DCS800-S01-2050-06/07	2050	1520	2280	1450	2175	1430	2860		
DCS800-S01-2500-06/07	2500	1940	2910	1840	2760	1880	3760	D7	-
DCS800-S01-3000-06/07	3000	2530	3795	2410	3615	2430	4860		
DCS800-S01-3300-06/07	3300	2416	3624	2300	3450	2277	4554	D7	-
DCS800-S01-4000-06/07	4000	3036	4554	2900	4350	2950	5900		
DCS800-S01-4800-06/07	4800	3734	5601	3608	5412	3700	7400		
<b>800 V</b>									
DCS800-S01-1900-08	1900	1500	2250	1430	2145	1400	2800	D6	-
DCS800-S01-2500-08	2500	1920	2880	1820	2730	1860	3720		
DCS800-S01-3000-08	3000	2500	3750	2400	3600	2400	4800	D7	-
DCS800-S01-3300-08	3300	2655	3983	2540	3810	2485	4970		
DCS800-S01-4000-08	4000	3036	4554	2889	4334	2933	5866	D7	-
DCS800-S01-4800-08	4800	3734	5601	3608	5412	3673	7346		
<b>990 V</b>									
DCS800-S01-2050-10	2050	1577	2366	1500	2250	1471	2942	D7	-
DCS800-S01-2600-10	2600	2000	3000	1900	2850	1922	3844		
DCS800-S01-3300-10	3300	2551	3827	2428	3642	2458	4916		
DCS800-S01-4000-10	4000	2975	4463	2878	4317	2918	5836		
<b>1190 V</b>				Data on request					

\* as option

### Note

AC current  $I_{AC} = 0.82 \cdot I_{DC}$

## Current ratings - IEC regenerative

Unit type	I <sub>DC I</sub>	I <sub>DC II</sub>		I <sub>DC III</sub>		I <sub>DC IV</sub>		Size	internal field curr.
		continu-ous	100 % 15 min	150 % 60 s	100 % 15 min	150 % 120 s	100 % 15 min		
<b>4-Q converters</b>									
<b>400 V / 525 V</b>	[A]	[A]		[A]		[A]			
DCS800-S02-0025-04/05	25	23	35	22	33	21	42	D1	6 A
DCS800-S02-0050-04/05	50	45	68	43	65	38	76		
DCS800-S02-0075-04/05	75	66	99	64	96	57	114		
DCS800-S02-0100-04/05	100	78	117	75	113	67	134		
DCS800-S02-0140-04/05	140	110	165	105	158	99	198		
DCS800-S02-0200-04/05	200	152	228	148	222	126	252	D2	15 A
DCS800-S02-0260-04/05	260	214	321	206	309	184	368		
DCS800-S02-0350-04/05	350	286	429	276	414	265	530	D3	20 A
DCS800-S02-0450-04/05	450	360	540	346	519	315	630		
DCS800-S02-0520-04/05	520	398	597	385	578	356	712		
DCS800-S02-0680-04/05	680	544	816	538	807	492	984	D4	25 A
DCS800-S02-0820-04/05	820	664	996	648	972	598	1196		
DCS800-S02-1000-04/05	1000	766	1149	736	1104	675	1350	D5	25 A * +S164
DCS800-S02-1200-04/05	1200	888	1332	872	1308	764	1528		
DCS800-S02-1500-04/05	1500	1200	1800	1156	1734	1104	2208		
DCS800-S02-2000-04/05	2000	1479	2219	1421	2132	1361	2722	D6	-
DCS800-S02-2050-05	2050	1550	2325	1480	2220	1450	2900		
DCS800-S02-2500-04/05	2500	2000	3000	1930	2895	1790	3580	D7	-
DCS800-S02-3000-04/05	3000	2330	3495	2250	3375	2080	4160		
DCS800-S02-3300-04/05	3300	2416	3624	2300	3450	2277	4554	D7	-
DCS800-S02-4000-04/05	4000	2977	4466	2855	4283	2795	5590		
DCS800-S02-5200-04/05	5200	3800	5700	3669	5504	3733	7466		
<b>600 V / 690 V</b>									
DCS800-S02-0320-06	320	256	384	246	369	235	470	D3	-
DCS800-S02-0650-06	650	514	771	508	762	462	924	D4	-
DCS800-S02-0900-06/07	900	684	1026	670	1005	594	1188	D5	25 A * +S164
DCS800-S02-1500-06/07	1500	1200	1800	1104	1656	1104	2208		
DCS800-S02-2050-06/07	2050	1520	2280	1450	2175	1430	2860	D6	-
DCS800-S02-2500-06/07	2500	1940	2910	1870	2805	1740	3480		
DCS800-S02-3000-06/07	3000	2270	3405	2190	3285	2030	4060	D7	-
DCS800-S02-3300-06/07	3300	2416	3624	2300	3450	2277	4554		
DCS800-S02-4000-06/07	4000	3036	4554	2900	4350	2950	5900		
DCS800-S02-4800-06/07	4800	3734	5601	3608	5412	3700	7400		
<b>800 V</b>									
DCS800-S02-1900-08	1900	1500	2250	1430	2145	1400	2800	D6	-
DCS800-S02-2500-08	2500	1910	2865	1850	2775	1710	3420		
DCS800-S02-3000-08	3000	2250	3375	2160	3240	2000	4000		
DCS800-S02-3300-08	3300	2655	3983	2540	3810	2485	4970	D7	-
DCS800-S02-4000-08	4000	3036	4554	2889	4334	2933	5866		
DCS800-S02-4800-08	4800	3734	5601	3608	5412	3673	7346		
<b>990 V</b>									
DCS800-S02-2050-10	2050	1577	2366	1500	2250	1471	2942	D7	-
DCS800-S02-2600-10	2600	2000	3000	1900	2850	1922	3844		
DCS800-S02-3300-10	3300	2551	3827	2428	3642	2458	4916		
DCS800-S02-4000-10	4000	2975	4463	2878	4317	2918	5836		
<b>1190 V</b>				Data on request					

\* as option

### Note

AC current  $I_{AC} = 0.82 \cdot I_{DC}$

### Sizing

**Note 1:** The ratings apply at ambient temperature of 40 °C (104 °F). In lower temperatures the D5, D6, D7 ratings are higher (except  $I_{max}$ ).

**Note 2:** Use the DriveSize PC tool for a more accurate dimensioning if the ambient temperature is below 40 °C (104 °F) or the drive is loaded cyclically.

### Duty cycle





## Current ratings – North America non-regenerative

Type code Non-Regenerative	Frame Size	Input RMS Current $A_{rms}$	Normal Duty		Standard Duty		Heavy Duty		Internal field current	Air Flow 60 Hz ft <sup>3</sup> /min	Heat Dissipation BTU/Hr
			$I_{2Nd}$ Adc	$P_{2Nd}$ HP	$I_{2Sd}$ Adc	$P_{2Sd}$ HP	$I_{2Hd}$ Adc	$P_{2Hd}$ HP			
500 Vdc											
DCS800-S01-0020-05	D1	16	19	10	18	10	18	10	6A	nonvent.	375
DCS800-S01-0045-05		37	42	25	38	20	38	20		210	580
DCS800-S01-0065-05		53	61	30	54	30	54	30		210	751
DCS800-S01-0090-05		73	88	50	78	40	78	40		210	955
DCS800-S01-0125-05		102	124	75	111	60	104	60		210	1297
DCS800-S01-0180-05	D2	147	171	100	164	100	148	75	15A	210	1911
DCS800-S01-0230-05		188	219	125	205	125	205	125		210	2491
DCS800-S01-0315-05	D3	257	300	150	264	150	264	150	20A	210	3105
DCS800-S01-0405-05		330	385	200	325	200	325	200		420	3822
DCS800-S01-0470-05		384	447	250	405	250	405	250		420	4504
DCS800-S01-0610-05+S171	D4	498	580	300	484	300	490	300	25A	610	6005
DCS800-S01-0740-05+S171		604	704	400	670	400	664	400		610	7302
DCS800-S01-0900-05+S171		734	865	500	795	500	795	500		1160	9145
DCS800-S01-1200-05+S164	D5	979	1105	700	950	600	851	550	25A	500	17402
DCS800-S01-1500-05+S164		1224	1450	900	1320	800	1280	800		500	18084
DCS800-S01-2000-05+S164		1632	1904	1100	1480	900	1479	900		500	22520
DCS800-S01-2050-05	D6	1673	1985	1250	1585	1000	1585	1000	External	940	27297
DCS800-S01-2500-05		2040	2395	1500	1986	1250	1990	1250		940	30709
DCS800-S01-3000-05		2448	2820	1750	2416	1500	2416	1500		940	37875
DCS800-S01-3300-05	D7	2693	3178	2000	2416	1500	2416	1500	External	2500	39922
DCS800-S01-4000-05		3264	3690	2250	2890	1750	2897	1750		2500	44358
DCS800-S01-5200-05		4243	4820	3000	3972	2500	3800	2250		2500	64831
600 Vdc											
DCS800-S01-0290-06	D3	237	280	200	268	200	268	200	External	210	3105
DCS800-S01-0590-06+S171	D4	481	561	400	480	300	470	300	External	610	6347
DCS800-S01-0900-06	D5	734	828	600	665	500	665	500	External	500	17402
DCS800-S01-1500-06		1224	1428	1000	1325	1000	1325	1000		500	21496
DCS800-S01-2000-06		1632	1850	1250	1490	1100	1479	1100		500	27638
DCS800-S01-2050-06	D6	1673	1850	1250	1490	1100	1479	1100	External	940	31392
DCS800-S01-2500-06		2040	2380	1750	1990	1500	1990	1500		940	34804
DCS800-S01-3000-06		2448	2790	2000	2380	1750	2380	1750		940	41628
DCS800-S01-3300-06	D7	2693	3035	2250	2380	1750	2380	1750	External	2500	44699
DCS800-S01-4000-06		3264	3720	2500	2970	2250	2970	2250		2500	51523
DCS800-S01-4800-06		3917	4410	3250	3507	2500	3507	2500		2500	66537
700 Vdc											
DCS800-S01-0900-07	D5	734	820	700	620	500	620	500	External	500	17402
DCS800-S01-1500-07		1224	1428	1250	1160	1000	1160	1000		500	21496
DCS800-S01-2000-07		1632	1850	1500	1490	1250	1479	1250		500	27638
DCS800-S01-2050-07	D6	1673	1850	1500	1490	1250	1479	1250	External	940	31392
DCS800-S01-2500-07		2040	2380	2000	1990	1750	1990	1750		940	34804
DCS800-S01-3000-07		2448	2790	2500	2380	2000	2380	2000		940	41628
DCS800-S01-3300-07	D7	2693	3035	2500	2380	2000	2380	2000	External	2500	44669
DCS800-S01-4000-07		3264	3720	3250	2970	2500	2970	2500		2500	51523
DCS800-S01-4800-07		3917	4480	4000	3507	3000	3507	3000		2500	66537
360 - 800 Vdc line voltage	DATA AVAILABLE UPON REQUEST										
450 - 990 Vdc line voltage	DATA AVAILABLE UPON REQUEST										
540 - 1200 Vdc line voltage	DATA AVAILABLE UPON REQUEST										

Normal Duty: 110% overload for 60 seconds, then <= 100% for 10 minutes

Standard Duty: 150% overload for 30 seconds, then <= 100% for 15 minutes

Heavy Duty: 150% overload for 60 seconds, then <= 100% for 15 minutes

### Current ratings – North America regenerative

Type code Regenerative	Frame Size	Input RMS Current A <sub>rms</sub>	Normal Duty		Standard Duty		Heavy Duty		Internal Field current	Air Flow 60 Hz ft <sup>3</sup> /min	Heat Dissipation BTU/Hr
			I <sub>2Nd</sub> A <sub>dc</sub>	P <sub>2Nd</sub> HP	I <sub>2Sd</sub> A <sub>dc</sub>	P <sub>2Sd</sub> HP	I <sub>2Hd</sub> A <sub>dc</sub>	P <sub>2Hd</sub> HP			
500 Vdc											
DCS800-S02-0025-05	D1	20	23	10	20	10	20	10	6A	nonvent.	375
DCS800-S02-0050-05		41	47	25	38	20	38	20		210	580
DCS800-S02-0075-05		61	71	40	54	30	54	30		210	751
DCS800-S02-0100-05		82	95	50	84	50	79	40		210	955
DCS800-S02-0140-05		114	133	75	125	75	110	60		210	1297
DCS800-S02-0200-05	D2	163	190	100	166	100	166	100	15A	210	1911
DCS800-S02-0260-05		212	247	150	208	125	208	125		210	2491
DCS800-S02-0350-05	D3	286	333	200	287	150	264	150	20A	210	3105
DCS800-S02-0450-05		367	428	250	360	200	357	200		420	3822
DCS800-S02-0520-05		424	489	300	405	250	405	250		420	4504
DCS800-S02-0680-05+S171	D4	506	647	400	605	300	544	300	25A	610	6005
DCS800-S02-0820-05+S171		669	806	500	740	400	664	400		610	7302
DCS800-S02-1000-05+S171		816	965	600	815	500	810	500		1160	9145
DCS800-S02-1200-05+S164	D5	979	1105	700	950	600	851	500	25A	500	17402
DCS800-S02-1500-05+S164		1224	1450	900	1320	800	1280	800		500	18084
DCS800-S02-2000-05+S164		1632	1885	1100	1490	900	1479	900		500	22520
DCS800-S02-2050-05	D6	1673	1985	1250	1585	1000	1585	1000	External	940	27297
DCS800-S02-2500-05		2040	2395	1500	1995	1250	1990	1250		940	30709
DCS800-S02-3000-05		2448	2820	1750	2382	1500	2382	1500		940	37875
DCS800-S02-3300-05	D7	2693	3178	2000	2416	1500	2416	1500	External	2500	39922
DCS800-S02-4000-05		3264	3690	2250	2890	1750	2890	1750		2500	44358
DCS800-S02-5200-05		4243	4820	3000	3972	2500	3800	2250		2500	64831
600 Vdc											
DCS800-S02-0320-06	D3	261	295	200	268	200	268	200	External	210	3105
DCS800-S02-0650-06+S171	D4	530	619	400	540	400	540	400	External	610	6347
DCS800-S02-0900-06	D5	734	828	600	665	500	665	500	External	500	17402
DCS800-S02-1500-06		1224	1428	1000	1325	1000	1325	1000		500	21496
DCS800-S02-2050-06	D6	1673	1850	1250	1490	1100	1490	1100	External	940	31392
DCS800-S02-2500-06		2040	2380	1750	1980	1500	1980	1500		940	34804
DCS800-S02-3000-06		2448	2790	2000	2293	1750	2293	1750		940	41628
DCS800-S02-3300-06	D7	2693	3035	2250	2370	1750	2370	1750	External	2500	44699
DCS800-S02-4000-06		3264	3720	2500	2970	2250	2970	2250		2500	51523
DCS800-S02-4800-06		3917	4410	3250	3507	2500	3507	2500		2500	66537
700 Vdc											
DCS800-S02-0900-07	D5	734	820	700	620	500	620	500	External	500	17402
DCS800-S02-1500-07		1224	1428	1250	1160	1000	1160	1000		500	21496
DCS800-S02-2050-07	D6	1673	1850	1500	1490	1250	1490	1250	External	940	31392
DCS800-S02-2500-07		2040	2380	2000	1990	1750	1983	1750		940	34804
DCS800-S02-3000-07		2448	2790	2500	2280	2000	2275	2000		940	41628
DCS800-S02-3300-07	D7	2693	3035	2500	2380	2000	2380	2000	External	2500	44669
DCS800-S02-4000-07		3264	3720	3250	2965	2500	2965	2500		2500	51523
DCS800-S02-4800-07		3917	4480	4000	3507	3000	3507	3000		2500	66537
360 - 800 Vdc line voltage	DATA AVAILABLE UPON REQUEST										
450 - 990 Vdc line voltage	DATA AVAILABLE UPON REQUEST										
540 - 1200 Vdc line voltage	DATA AVAILABLE UPON REQUEST										

Normal Duty: 110% overload for 60 seconds, then <= 100% for 10 minutes  
 Standard Duty: 150% overload for 30 seconds, then <= 100% for 15 minutes  
 Heavy Duty: 150% overload for 60 seconds, then <= 100% for 15 minutes

## Control Board SDCS-CON-4

Layout of the control board SDCS-CON-4

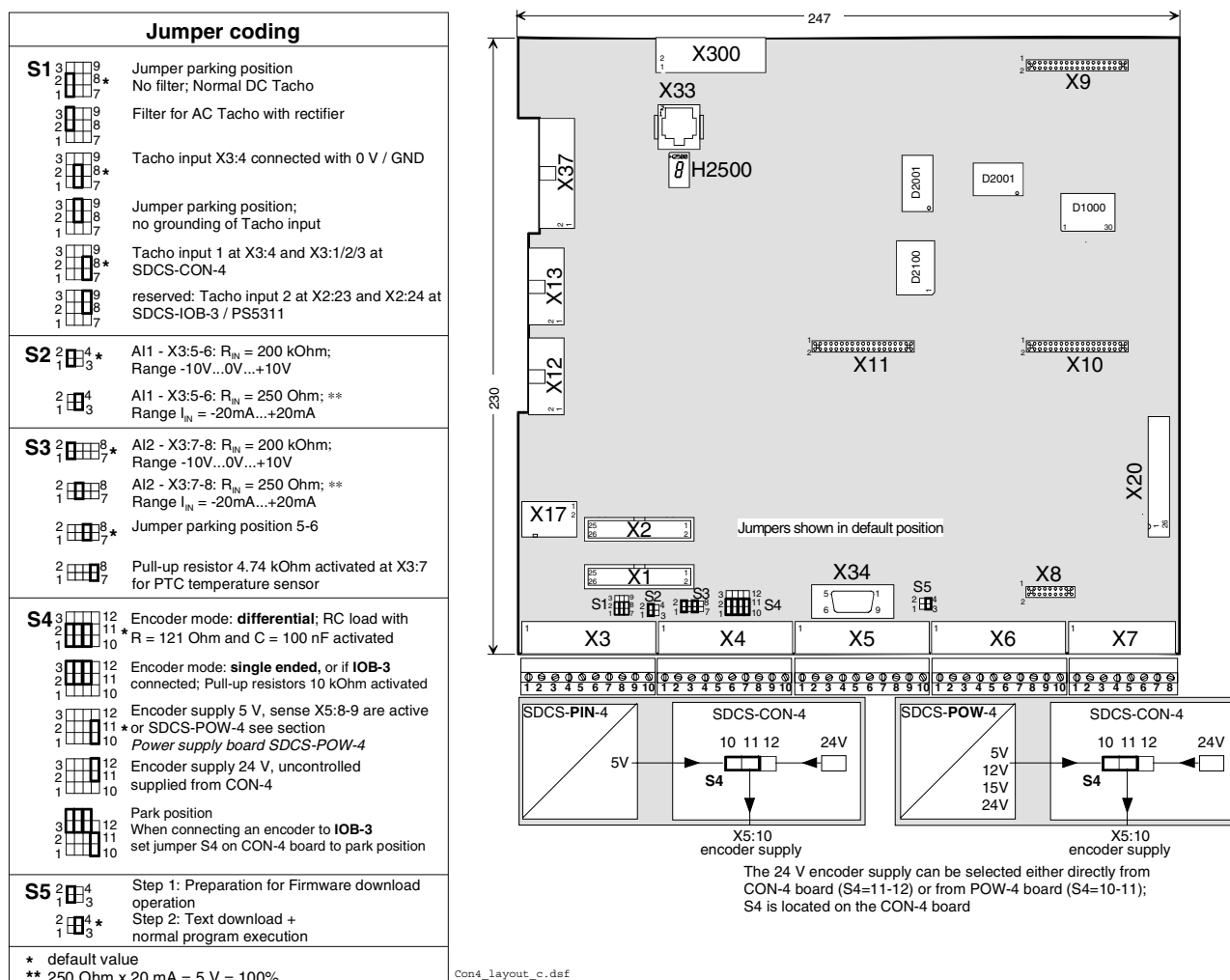

### Memory circuit

SDCS-CON-4 board is equipped with FlashPROM which contains the firmware plus the stored parameters. Parameters handled by DCS800 panel or DWL, PCTool or by Serial communication parameter service are stored immediately in the FlashPROM.

Parameters handled by cyclic serial communication (dataset table Group 90 - 92 and pointers group 51) are not stored in the Flash PROM. They must be stored by means of ParAppSave (16.6) service.

The faultlogger entries are stored in the FlashPROM during power down (auxiliary power supply OFF).

### Watchdog function

The control board has an internal watchdog. The watchdog controls the running of the control board program. If the watchdog trips, it has the following effects:

- Writing to FPROM is disabled.
- Thyristor firing control is reset and disabled.
- Digital outputs are forced low.
- Programmable analogue outputs are reset to zero, 0V.

## Seven segment display

A seven segment display is located on the control board SDCS-CON-4 and it shows the state of drive.

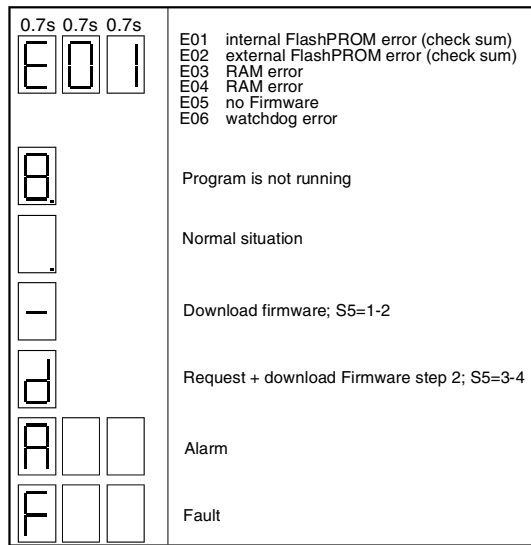

7seg\_DCS8.dsF

## Terminal description

**X37:** Connector is used for supply of SDCS-CON-4 from SDCS-POW-1, SDCS-POW-4, SDCS-PIN-4 supply voltage can be measured to ground.

X37:3= 48V

X37:5=24V

X37:7=15V

X37:11=-15V

X37:13=5V encoder

X37:23=5V CPU

### Supply voltage monitoring

5V CPU is monitored by 4.75 V and forces CPU to reset. In parallel the CPU monitors Powerfail signal from power supply (SDCS-PIN-4 or SDCS-POW-4).

**X12:** and **X13:** connector are used for measurement voltage, current and temperature and firing thyristors by SDCS-PIN-4/PIN-41/PIN-46/PIN-41/PIN-51.

see chapter *Technical data*

**X17:** and **X300:** are routine test connectors.

**X1:** and **X2:** are used to connect SDCS-IOB-2 and SDCS-IOB-3 board.

see chapter *Technical data*

**X33:** is used to connect DCS800 Panel. It can be connected direct via 40 mm jack or via CAT 1:1 cable (RJ45).

**X34:** is used for download firmware for DWL and IEC61131 programming connection.

The **RS232** interface is normally used for setting parameter in the drive via the DWL PC Tool.  
The default settings of this interface are as follows:

Signal level:	RS232 (+12V / -12V)
Data format:	UART
Message format:	Modbus-Protocol
Transmission method:	half-duplex
Baudrate:	DriveWindow Light: variable CodeSys download: 38.4 kBaud FDT firmware download: self-adapting
Number of Data bits:	8
Number of Stop bits:	1
Parity-Bit:	odd

X34:	Description
1	not connected
2	TxD
3	RxD
4	not connected
5	SGND Signal ground
6...9	not connected

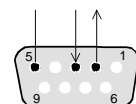

X34:

**X8:** is needed for SDCS-DSL-4 board which provides the serial communication interface to field exciters, 12-pulse converters, master-follower and mailbox to other converters.

**X9:**, **X10:** and **X11:** are used for extension IO modules and serial communication interface adapter.

For detailed description see manual *Hardware extension RAIO Analog I/O Extension*

*Hardware extension RDIO Digital I/O Extension*

*DCS800 61131 Programming target*

see chapter SDCS-COM-8 board

X20 (Slot 4) is used for Memory Card, see description IEC61131 programming.

Prepared function of:

	Slot 1 X9:	Slot 2 X10:	Slot 3 X11:	Slot 4 X20:
RDIO / RAIO	x	x	x	
R... Fieldbus adapter	x			
SDCS-COM-8			x	
Second fieldbus RMBA		x	x	
Memory Card				x

### Digital and analogue I/O connection of the SDCS-CON-4

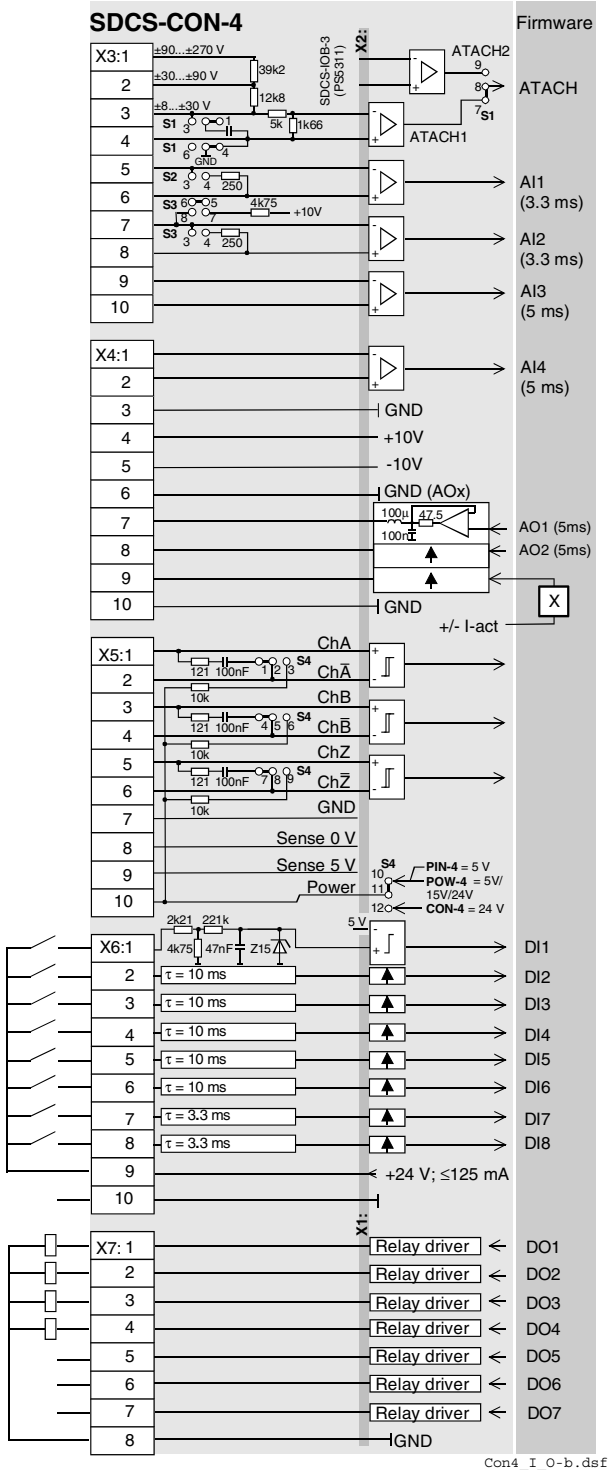

Con4\_I\_O-b.dsf

Resolution [bit]	Input/output values Hardware	Scaling by	Common mode range	Remarks
15 + sign	$\pm 90 \dots \pm 270 \text{ V}$ $\pm 30 \dots 90 \text{ V}$ $\pm 8 \dots 30 \text{ V}$	Firmware	$\pm 15 \text{ V}$	
15 + sign	$-10 \dots 0 \dots +10 \text{ V}$	Firmware	$\pm 15 \text{ V}$	
15 + sign	$-10 \dots 0 \dots +10 \text{ V}$	Firmware	$\pm 15 \text{ V}$	
15 + sign	$-10 \dots 0 \dots +10 \text{ V}$	Firmware	$\pm 15 \text{ V}$	
15 + sign	$-10 \dots 0 \dots +10 \text{ V}$	Firmware	$\pm 15 \text{ V}$	

			Power	
	+10 V		$\leq 5 \text{ mA}$	for ext. use
	-10 V		$\leq 5 \text{ mA}$	e.g. refer. pot.
11 + sign	$-10 \dots 0 \dots +10 \text{ V}$	Firmware	$\leq 5 \text{ mA}$	
11 + sign	$-10 \dots 0 \dots +10 \text{ V}$	Firmware	$\leq 5 \text{ mA}$	
	$-10 \dots 0 \dots +10 \text{ V}$	Firmware + Hardw.	$\leq 5 \text{ mA}$	8 V -> min. of 325% of [99.03] or 230% of [4.05]

Encoder supply		Remarks
		Inputs not isolated Impedance = 120 $\Omega$ if selected max. frequency $\leq 300 \text{ kHz}$
5 V	$\leq 250 \text{ mA}$	Sense lines for GND and supply to correct voltage drops on cable (only if 5 V encoder is in use).
24 V	$\leq 200 \text{ mA}$	

Input value	Signal definition by	Remarks
0...7.3 V 7.5...50 V	Firmware	-> "0" status -> "1" status

Output value	Signal definition by	Remarks
50 * mA 22 V at no load	Firmware	Current limit for all 7 outputs = 160 mA Do not apply any reverse voltages!

\* short circuit protected

① gain can be varied in 15 steps between 1 and 4 by software parameter

## Interface Board SDCS-COM-8

This board must be used together with a DCS800 to provide same serial communication DDCS options as ACS800.

Furthermore the board is equipped with four optical channels (max. data transmission speed is 4 Mb for each optical channel):

- **Channel 0** is used to communicate data from the overriding control (FCI, APC2, AC800M, Nxxx-xx (adapter modules for fieldbus), AC80) or via adapter modules from other controllers) to the DCS800-drive.
- **Channel 1** is used for DDCS I/O extension. AIMA-01 board see separate documentation.
- **Channel 2** (Master-Follower) is used to operate two or more drives dependent on each other.
- **Channel 3** is prepared to connect the PC tool for commissioning and maintenance (DriveWindow).
- **Connector X19** is used for CDP 312 panel as well as interface board NDPI.

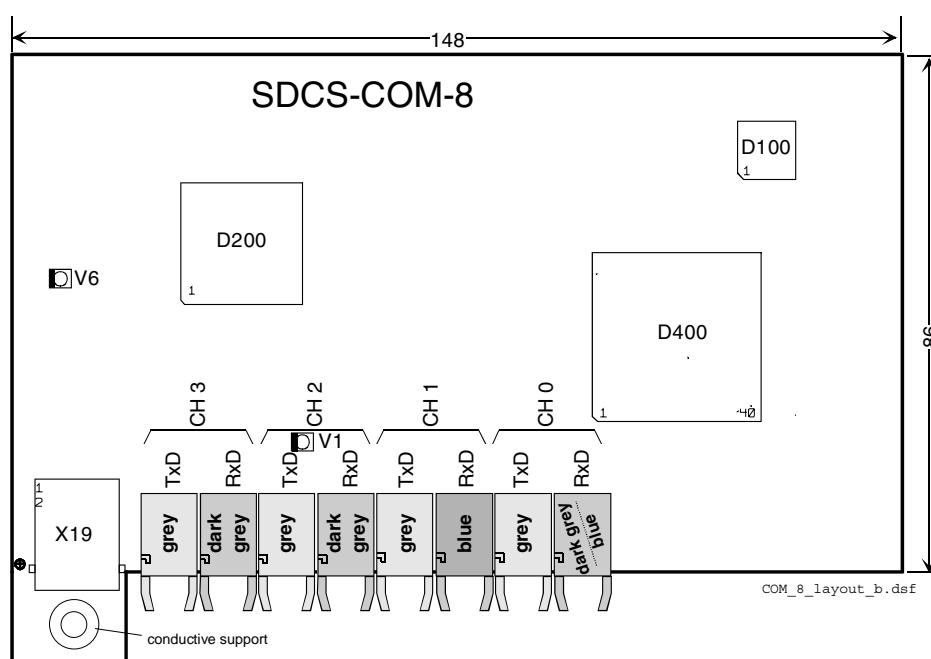

### Explanation of LEDs on SDCS-COM-8

LED	color	Meaning
V6	green	5 V supply ok
V1	red	blinking: boot procedure permanent: SDCS-COM-8 fault

Type	Revision	optical components				Channel 0 used for	max. driver current	Conductive support	
		Ch 0 PLC	Ch 1 I/O	Ch 2 M/F	Ch 3 DW				
SDCS-COM-81	from D...F	10 Mb	5 Mb	10 Mb	10 Mb	other interfaces	Ch 0, 2, 3	50 mA	
SDCS-COM-82	from D...F	5 Mb	5 Mb	10 Mb	10 Mb	Fieldbus adapter modules Nxxx-xx	Ch 2, 3	50 mA	
SDCS-COM-81	from G...F	10 Mb	5 Mb	10 Mb	10 Mb	other interfaces	Ch 0, 2, 3	50 mA	x
SDCS-COM-82	from G...F	5 Mb	5 Mb	10 Mb	10 Mb	Fieldbus adapter modules Nxxx-xx	Ch 2, 3	50 mA	x

Color of optical components:

5 Mb -> blue driver current maximum 30 mA

**Remark:** Only channels with the same components (e.g. 10 Mb component) may be connected to each other.

### Ch2 SDCS-COM-8 Master-Follower connections

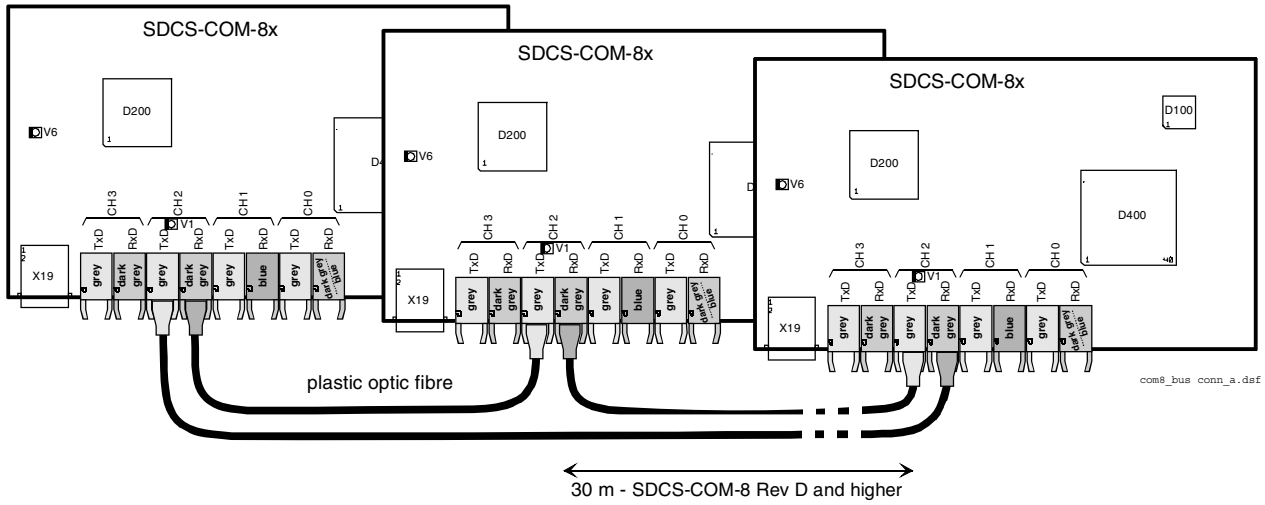

### Ch0 Drive Bus connection to Advant Controller (star)

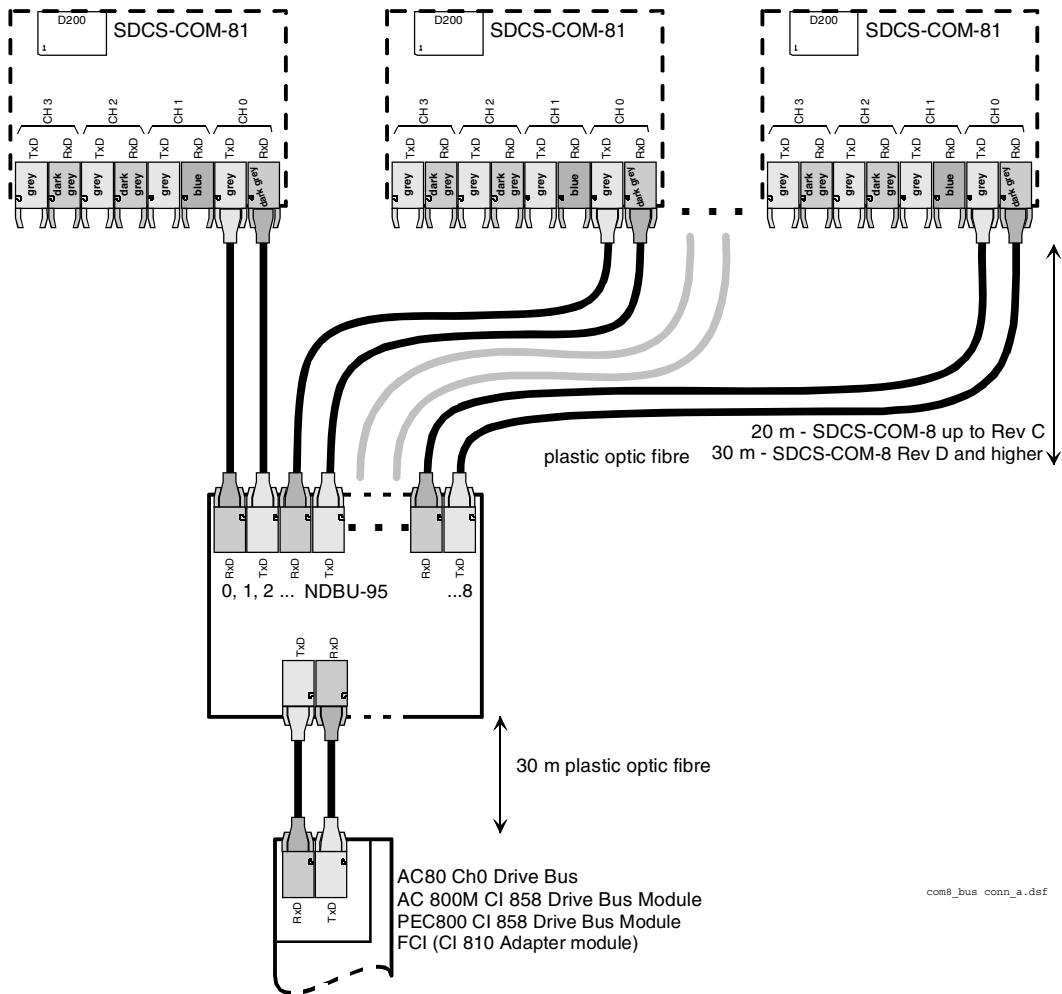



### Ch0 Connection to overriding control (Nxxx fieldbus adapter)

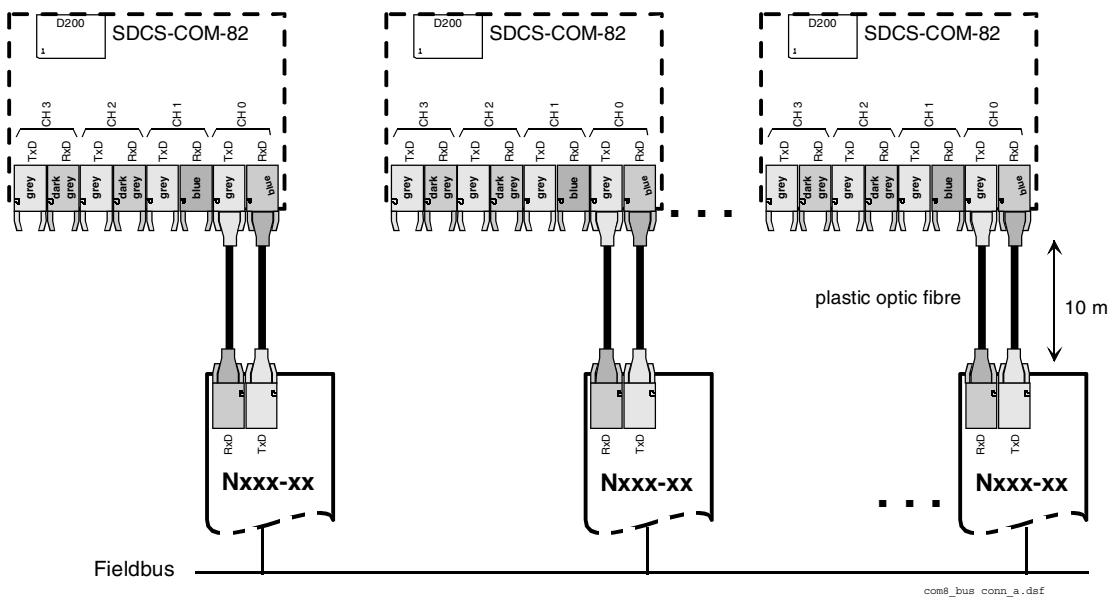

### Ch3 Ring connection to PC tool DriveWindow

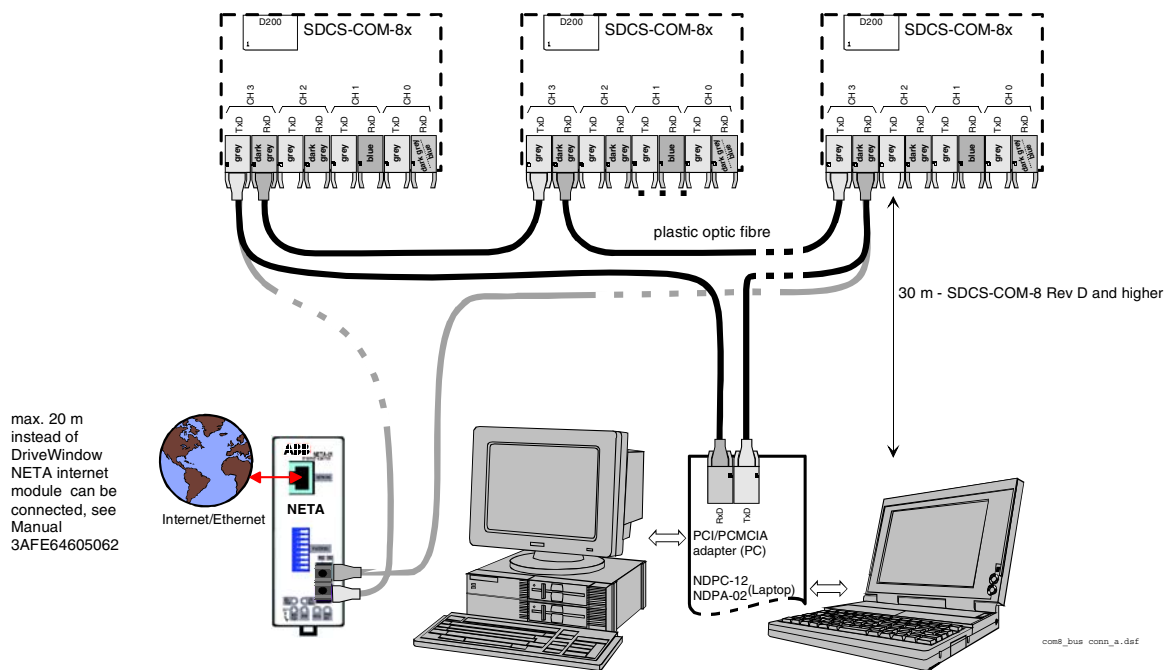

### Ch3 Star connection to PC tool DriveWindow

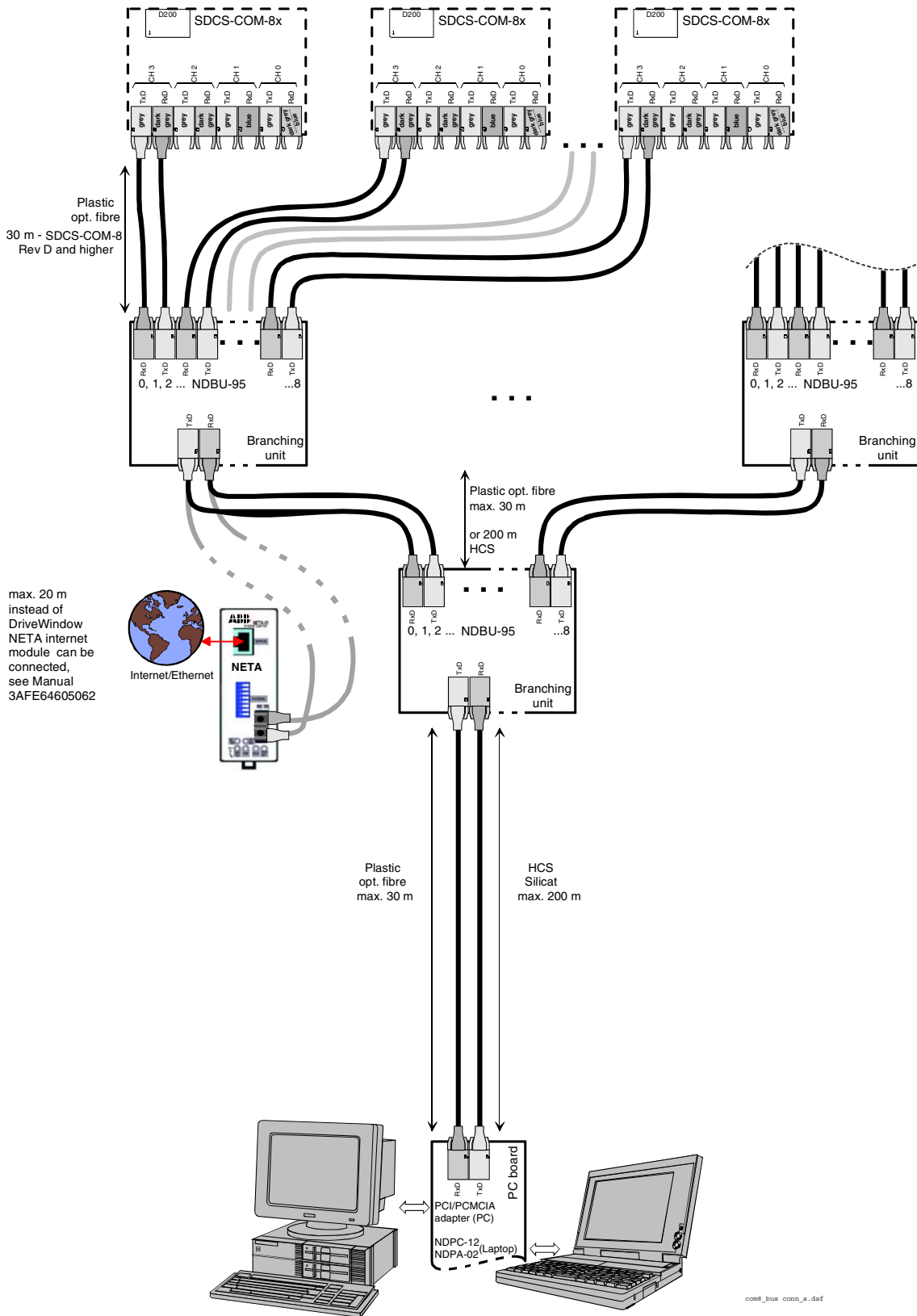

## DDCS Branching unit NDBU-95

DDCS Branching Unit (DBU) is used (for DCS 600/DCS800) to implement the star topology of DDCS link. This allows a slave unit to fail or become unpowered without disabling the communication. The NDBU receives messages from the master (PC) and sends them to all the slave units simultaneously. Each slave unit has an individual address and only the addressed slave unit sends a reply message to the master. It is also possible to use NDBU thus enabling peer-to-peer communication.

NDBU-95 DDCS Branching Unit has nine output channels where messages from the master are sent. The reply message sent by one slave unit is delivered to the master and it can be delivered also to other slaves if necessary. Several NDBU-95s can be used in parallel, in series or in any combination of these. The maximum distance between the master and NDBU-95 as well as between two NDBU-95s, see manual *Branching units NDBU-95*.

### Technical specifications

#### Optical links:

Master channels	1 DDCS input and 1 DDCS output
Slave channels	9 DDCS inputs and 9 DDCS outputs
Data rate	1 - 4 MBd, programmable
Driving current	20 mA, 30 mA, 50 mA + channel disabling, programmable
Monitoring	a green LED for each channel, switched on when NDBU is receiving messages
Transmission device	10 Mb component for each channel

#### Power supply:

Input voltage	+24 VDC $\pm$ 10%
Input current	300 mA
Monitoring	a green LED switched on when the output voltage is normal

**Operating temperature:** +0 ... +50 °C

**PCB dimensions:** s. diagram beside

**Remark:** Only channels with the same components (e.g. 10 Mb component) may be connected to each other.

For further information see Appendix D in the DriveWindow User's Manual.

#### Note

For addressing and automatic node numbering of the drives and branching units see DriveWindow documentation.

Layout of the NDBU-95 branching unit

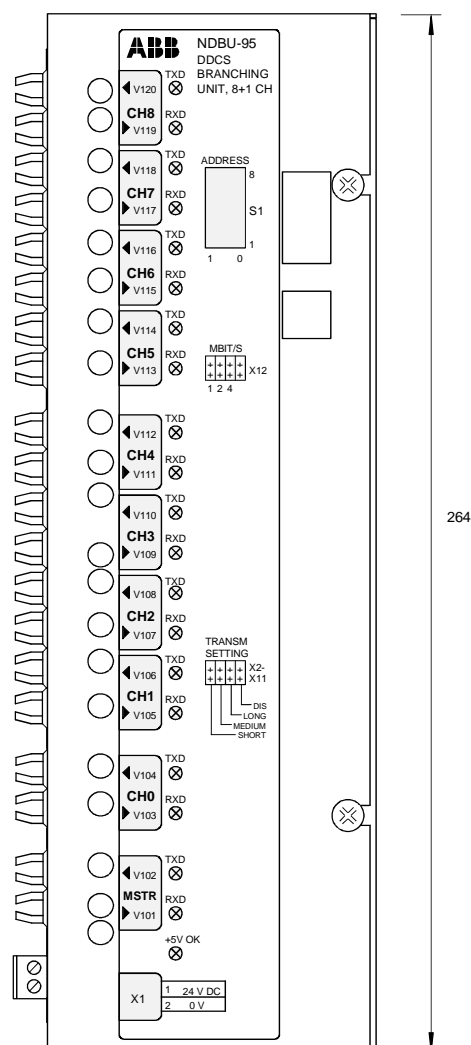
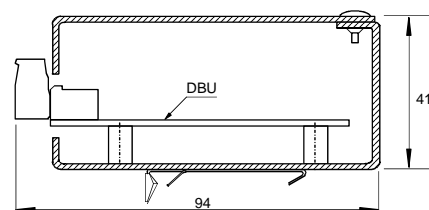

## SDCS-DSL Board

The SDCS-DSL board provides a drive to drive communication. The communication hardware and protocol is based on CAN bus.

This communication will be used for 12-pulse operation, communication to field exciter either single phase or three phase field exciter.

The communication hardware is equipped with an isolated supply and isolated transmitter. The terminator can be set by Jumper S2 and S1 selection of termination see section *DCS Link Wiring*

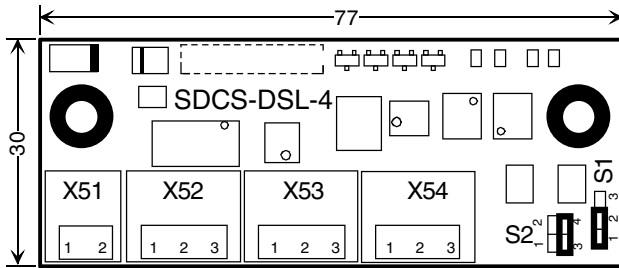

DSL-4\_drw\_b.dsf

Jumper coding	
<b>S1 Bus termination</b>	
	120 Ohm
	* no termination, park position
<b>S2 Ground termination</b>	
	0 Ohm (direct) ground termination
	200 kOhm R-C ground termination
	* no termination, park position
* default value	

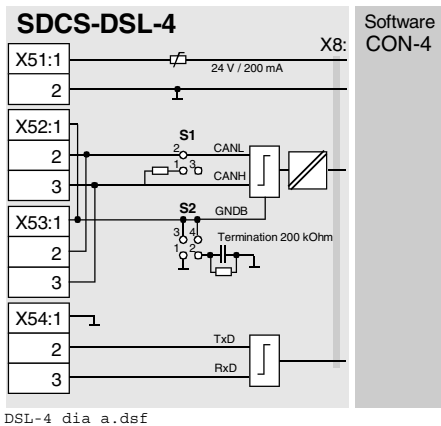

Supply	Remarks
24 V	≤200 mA
24 V grounded supply for FEX425 internal and DCF803-0035 field exciter units; short circuit protected 250 mA	

DSL communication		Remarks
Bus termination		
S1	1-2	120 ohm
	2-3	no termination; park position
Ground termination		
S2	2-4	200 kOhm R-C ground termination
	1-3	0 Ohm ground termination
	3-4	no termination; park position
RS 485 communication		Remarks
		no isolation

## Digital I/O board SDCS-IOB-2

As described at the beginning of the chapter, there are various options for configuring the inputs/outputs. The board IOB-2x has 8 digital inputs and 8 digital outputs.

There are three different types existing, which differ at the input voltage level:

- SDCS-IOB-21 24...48V DC
- SDCS-IOB-22 115 V AC
- SDCS-IOB-23 230 V AC

The inputs are filtered and galvanically isolated by using optocouplers. Inputs can form two galvanically separated groups by using either X7:1 or X7:2.

If these boards are in use, they have to be mounted outside the DCS module. They must be mounted in a way, that the conductive supports have a good connection to ground of the installation.

I/O via SDCS-IOB-2x / IOB-3 and SDCS-CON-4

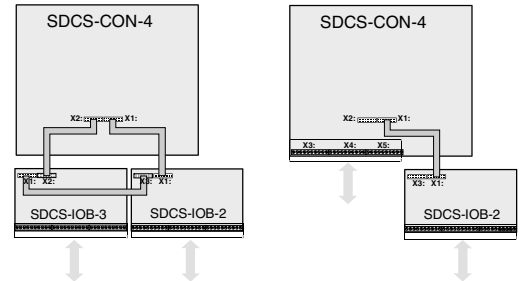

The cable length between X1:/X1: and X2:/X2: is max. 1.7 m (D1...D4 converters)  
 is max. 4 m screened (required for D7 converters)  
 between X1:/X3: is max. 0.5 m because of EMC reasons. See chapter *Other cables*.

Layout and jumper settings of the SDCS-IOB-2x board

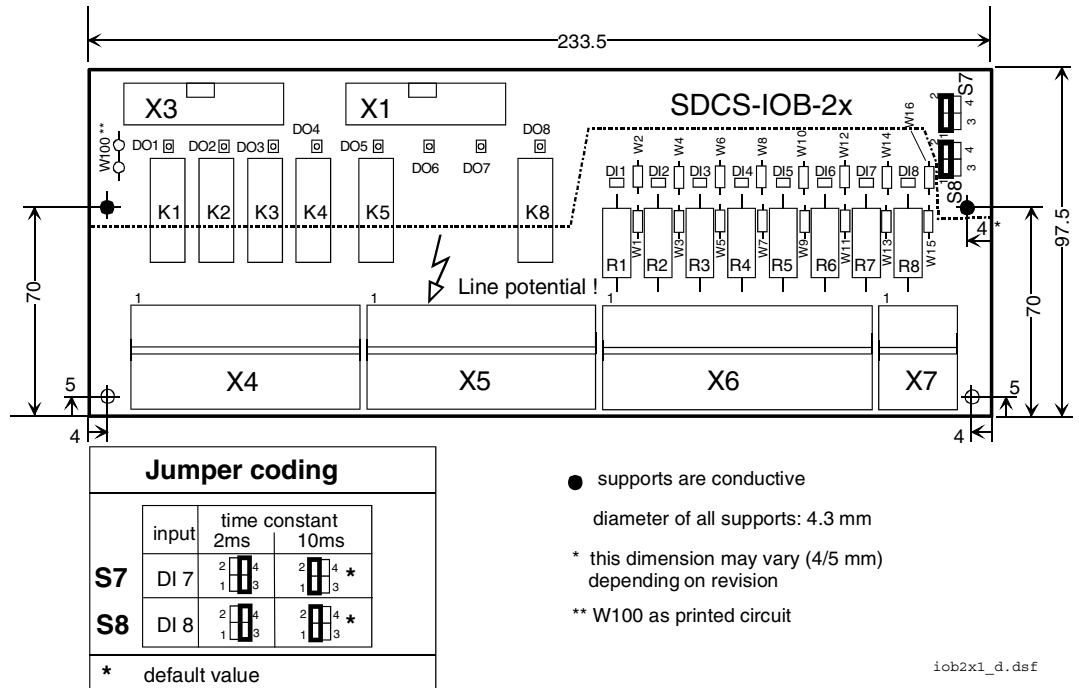

There is a card holder available as option for fastening the SDCS-IOB-2 board. For more information see chapter *Dimensional drawings*.

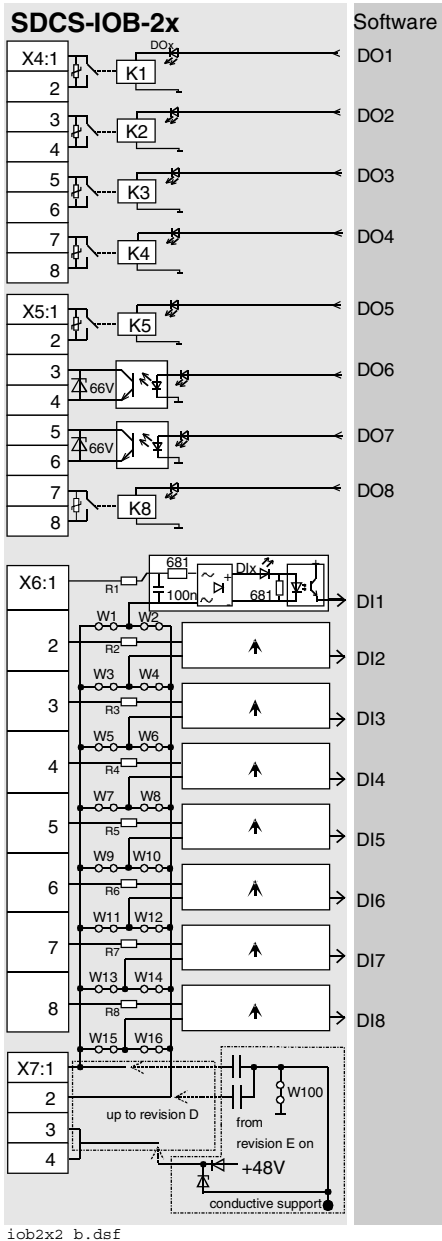

**Note:**

When the SDCS-CON-4 control board with the SDCS-IOB-2 I/O board is installed, terminals X6: and X7: on the SDCS-CON-4 must not be used.

Output value	Signal definition by	Remarks
K1...K5, K8	Firmware	potential-isolated by relays (NO contact element) Contact ratings: <b>AC:</b> ≤250 V~/ ≤3 A~ <b>DC:</b> ≤24 V~/ ≤3 A- or ≤115/230 V~/ ≤0.3 A- MOV-protected (275 V)
K6, K7	Firmware	potential-isolated by optocoupler Switching capacity: ≤50 mA external voltage: ≤24 V-

X4:, X5: are screw-clamp terminal types for leads up to 4 mm<sup>2</sup> cross-sectional area.

Default values are shown within the software diagrams.

The ground potential of the digital outputs may vary within ±100 V to each other.

Input value	Signal definition by	Remarks
Channel 1...8	Firmware	potential-isolated by optocoupler <b>(24...48V-)</b> R1...R8 = 4.7 kΩ -> "0 signal"
IOB-21		0...8 V -> "1 signal"
IOB-22		18...60 V -> "0 signal"
IOB-23	Firmware	0...20 V -> "1 signal"
		60...130 V <b>(230 V~)</b> R1...R8 = 47 kΩ -> "0 signal"
		0...40 V -> "1 sig."
		90...250 V including tolerance; absolute max. values

X6: / X7: are screw-clamp terminal types for leads up to 4 mm<sup>2</sup> cross-sectional area

**Input resistance:** see diagram.

**Input smoothing time constant:** see diagram.

**Smoothing time constant of channel 7 and 8** can be changed; see fig. before.

**Power supply for digital inputs X7:3,4:**

- 48V / ≤50mA
- not galv. isolated from the DCS electronics!
- only available at **SDCS-IOB-21**

If the inputs are supplied from the internal +48 V (X7:3 and/or X7:4) a connection must be done from either X7:1 and/or X7:2 to ground of the DCS800 module. In default condition ground is identical to the converter's frame.

If the inputs are supplied by any external source (+48 V DC, 115 V AC or 230 V AC) the neutral line / - line must be connected to either X7:1 or X7:2. If the inputs should be controlled with the same voltage level, but from two different voltage sources, having probably two different ground levels, the first neutral line should be connected to X7:1 and the second to X7:2. In this case the jumpers Wx connecting the inputs to X7:2, but controlled by the source, connected to X7:1, must be cut off.

The same method is needed for the other jumpers Wx.

High frequency grounding is done by 100 nF capacitor.

## Analogue and encoder I/O board SDCS-IOB-3

As described at the beginning of the chapter, there are various options for configuring the inputs/outputs. The board SDCS-IOB-3 consists of the 5 analogue inputs, 3 analogue outputs, the galvanical isolated pulse encoder interface and a current source for temperature measuring devices. If these boards are in use, they have to be mounted outside the DCS module. They must be mounted in a way, that the conductive supports have a good connection to ground of the installation. The cable length between X1:/X1: and X2:/X2: is max. 1.7 m (D1...D4 converters) is max. 4 m screened (required for D7 converters) between X1:/X3: is max. 0.5 m because of EMC reasons.

I/O via SDCS-IOB-2x / IOB-3 and SDCS-CON-4

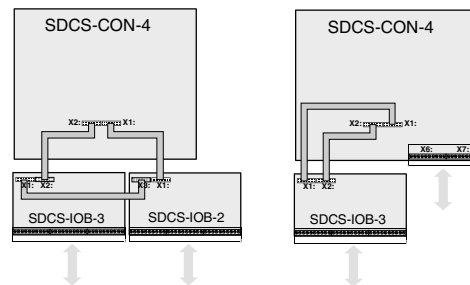

### Layout and jumper settings of the SDCS-IOB-3 board

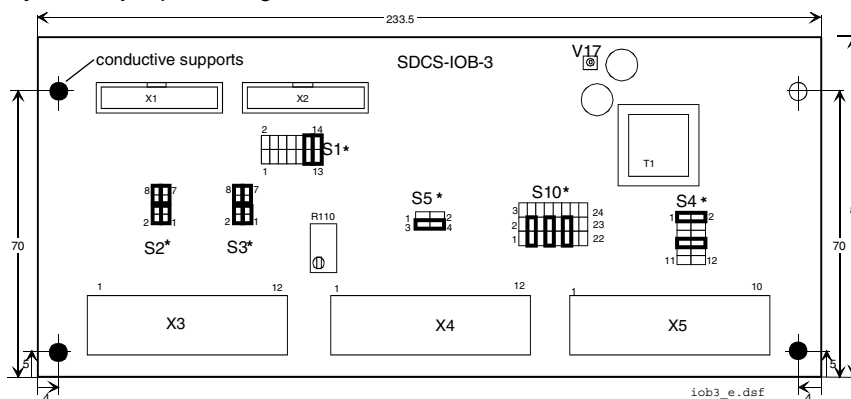

#### Jumper coding

Functionality of analogue inputs			
S1	Ch	Paralleling of 500 Ω between input terminal for 0/4...20 mA	Residual current measurement X3:11 X3:12
S2	AI1	S1:1-2	gain = 1 * -10V...+10V
S3	AI2	S1:3-4	gain = 10 -1V...+1V
	AI3	S1:5-6	
	AI4	S1:7-8	
		S1:9-10	

S10	Characteristics for pulse encoder inputs
	single ended push/pull * (5V/12V/24V)
	single ended open collector
	differential: 5 V      12/24 V *      13 mA

  

\* default value

When using SDCS-IOB-3 encoder input, the following S4 jumper setting on SDCS-CON-4 has to be made

**S4 on SDCS-CON-4**

There is a card holder available as option for fastening the SDCS-IOB-3 board. For more information see chapter *Dimensional drawings*.

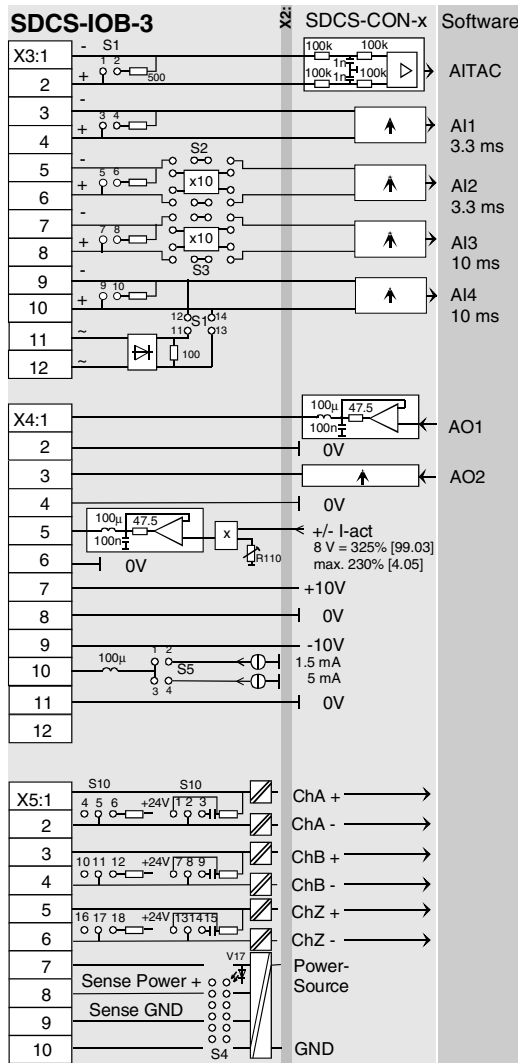

iob3x2\_g.def

**Note:**

When the SDCS-CON-4 control board with the SDCS-IOB-3 I/O board is installed, analogue tachometer input at SDCS-CON-4 should be used:

Terminals X3: (except for connector 1, 2, 3, 4), X4: and X5: on the SDCS-CON-4 must not be used.

Resolution [bit]	Input/output values	Scaling by	Common mode range	Remarks
15 + sign	-10...0...+10 V	Firmware	±20 V	①②③⑥
15 + sign	-10...0...+10 V	Firmware	±20 V	①②③
15 + sign	-10...0...+10 V	Firmware	±40 V	①②③④⑤
15 + sign	-10...0...+10 V	Firmware	±40 V	①②③④⑤
15 + sign	-10...0...+10 V	Firmware	±40 V	①②③
				⑦
			<b>Power</b>	
11 + sign	-10...0...+10 V	Firmware	≤5 mA*	
11 + sign	-10...0...+10 V	Firmware	≤5 mA*	
analogue	-10...0...+10 V	R110	≤5 mA*	gain: 0.5...5
	R <sub>i</sub> = 3 Ω		≤5 mA*	for external use
			≤5 mA*	e.g. reference pot.
	1.5 mA 5 mA			Curr. source for PTC or PT100

Encoder supply	Remarks
5 V 12 V / 24 V	Inputs not isolated Impedance = 120 Ω if selected max. frequency ≤300 kHz
	Sense lines for GND and supply to correct voltage drops on cable (only if 5V/12V encoder is in use)

- ① total smoothing time ≤2 ms
  - ② -20...0...+20 mA by setting S1
  - ③ 4...20 mA by ② + Software function
  - ④ -1...0...-1 V by setting S2/S3 (CMR ±10 V)
  - ⑤ -2...0...-2 mA by setting S2/S3 + S1 (CMR ±10 V)
  - ⑥ designated for PT100 evaluation per firmware and hardware
  - ⑦ should always be used directly at SDCS-CON-4 X3:1...4
- \* short circuit proof

⑦ **Residual current detection** is selected as default. The jumpers S1:11-12 and S1:13-14 are set, inputs X3:9 and X3:10 and jumper S1:9-10 must not be used and inputs X3:11 and X3:12 serve as input for the current signal taken from a current transformer. This detection is based on a sum current transformer where the secondary is connected through a diode bridge to 100 Ohm resistor. Voltage will appear across the resistor, if the sum of the 3-phase current is not zero. In case AI4 should be used for a different purpose, use the inputs/jumpers accordingly and take the block diagram as a help.

**Restrictions using jumper S1, S2 or S3:**

The selection for the burden resistor across the input terminals can be done independent from S2 or S3 settings for inputs AITAC, AI1, AI2, AI3 and AI4.

If the gain is set to 10 by using S2 or S3 and the 500 Ω burden resistor is activated, the input signal level is changed to -2 mA...0...+2 mA.

For input AI4 there are the following configurations available:

- input range "20mA", or
- input range "10V", or
- earth fault monitoring by Isum not equal to zero via X3:11 and X3:12



## Power Supply Board SDCS-POW-4

The SDCS-POW-4 board is designed for DCS800 converter modules and is mounted on the electronic support. This board is used for all types of modules type D5, D6 and D7 (>1000 A and rebuild system DCS800-R).

The SDCS-POW-4 works on a switched mode basis in fly back configuration. It generates all necessary DC voltages for the SDCS-CON-4 and all other electronic boards. The input voltage is automatically detected and set to either 230 V AC or to 115 V AC. The following figure shows the instructions for the selection of the encoder supply voltage.

If SDCS-CON-4 input X5: is used for encoder speed measurement, the incremental encoder supply voltage for 5V, 12 V or 15 V must be selected by jumpers S3, S4 and S5.

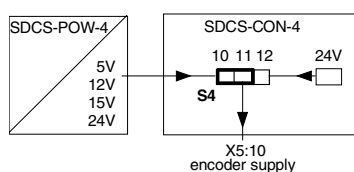

The 24 V encoder supply can be selected either directly from CON-4 board (S4=11-12) or from POW-4 board (S4=10-11); S4 is located on the CON-4 board

Jumper coding					
X3	Encoder supply selection				
X4	X3	X4	X5	Sense-function	
X5	5 V *				yes
	12 V				yes
	15 V				no
	24 V				no

\* default value

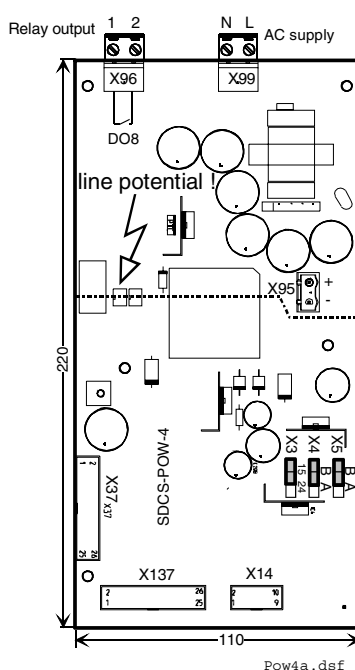

X37 and X137 are connected in parallel  
X14 is used for SDCS-PAR-1 hard parallel converters

### Auxiliary supply voltage X99

Supply voltage	115 V AC	230 V AC
Tolerance	-15%/+10%	-15%/+10%
Frequency	45 Hz ... 65 Hz	45 Hz ... 65 Hz
Power consumption	120 VA	120 VA
Power loss	≤60 W	≤60 W
Inrush current *	20 A / 20 ms	10 A / 20 ms
recommended fusing	6 AT	6 AT
Mains buffering	min 30 ms	min 300 ms
Powerfail	95 V	95 V

\* Frequently switching ON and OFF increases inrush current

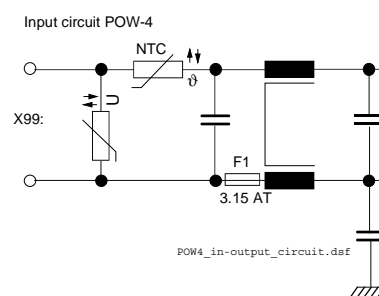

### Output X96-DO8

Potential isolated by relay (NO contact)  
MOV- element (275 V)

Contact rating: **AC:** ≤250 V~/ ≤3 A~  
**DC:** ≤24 V~/ ≤3 A  
or ≤115/230 V~/ ≤0.3 A-

### Backup supply X95

These two terminals are used to add additional capacitance to the existing ones to increase the mains buffering time. More detailed data is available on request via your ABB representative.

# Interface Board SDCS-PIN-4

## General

The SDCS-PIN-4 board is designed for DCS800 Converter modules sizes D1 up to size D4 (20 A...1000 A) the board has three different functions:

1. Power supply of CON-4 board and the connected plug-in modules
2. Control of armature bridge and measurement
3. Control of on-board field exciter and field current measurement

The board is mounted conducting ground at points (  ) inside the module.

The board is used for supply voltages from 230 V up to 525 V, 600 V.

The converter identification is made by TYPECODE 97.01 (and not by hardware)!

The converter identification manages the burden resistor setting and 2-Q or 4-Q bridges operation.

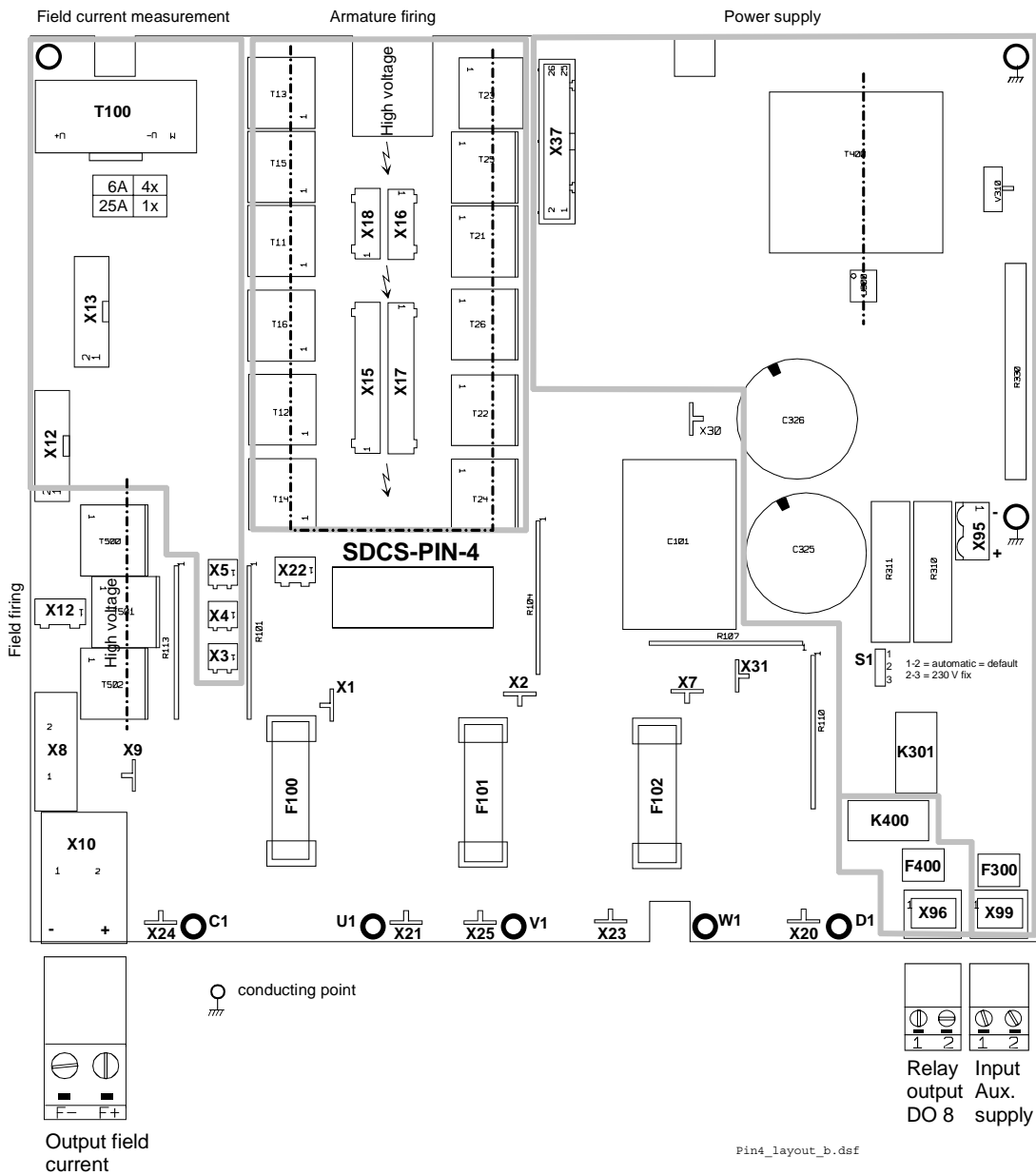

Different functional areas on SDCS-PIN-4

## Power supply

The power supply (X99:) operates on fly back configuration. The internal DC link voltage is 310 V.

The power supply automatically adapts the supply input voltage either 230 V or 115 V and switches relays K301.

In case of varying 230 V input voltage (e.g. generator network) the operation must be clamped to 230 V by Jumper S1= 2-3 230 V operation

## Technical data

### AC Supply voltage

Supply voltage	115 V AC	230 V AC
Tolerance	-15%/+10%	-15%/+10%
Frequency	45 Hz ... 65 Hz	45 Hz ... 65 Hz
Power consumption	120 VA	120 VA
Power loss	≤60 W	≤60 W
Inrush current	20 A / 20 ms	10 A / 20 ms
recommended fusing	6 AT	6 AT
Mains buffering	min 30 ms	min 30 ms
Powerfail	95 V	185 V

### Backup supply

The terminal X95 are used to add additional capacitance to the existing ones to increase the mains buffering time. More detailed data is available on request via your ABB representative.

### S1

1-2 -> automatic detection of input voltage range (default)

2-3 -> 230 V operation fix

### X96: Output DO8

Isolated relay (NO contact)

Contact rating: AC: 230 V~/ <3 A~

DC: 24 V-/ <3 A-

or 115/230 V-/ <0.3 A-

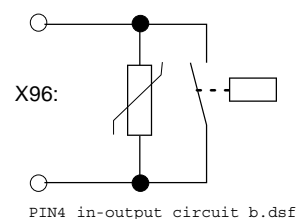

### X99: Input circuit PIN-4

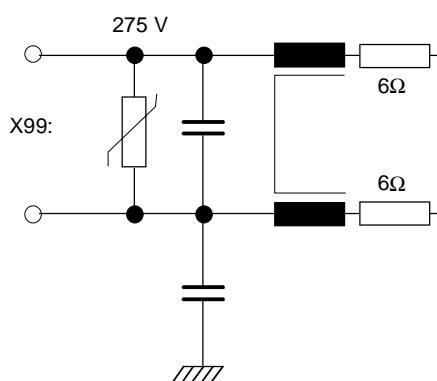

## Armature circuit interface

The function for armature circuit interface consist of:

- Firing the armature bridge of 6 or 12 thyristors.
- High ohmic measurement of DC and AC voltage.
- Interface for AC current transformer for current measurement.
- Snubber circuit for the thyristor protection together with resistor R1 on heatsink.
- Interface for heatsink temperature measurement with a PTC resistor.
- Fuses for overvoltage protection and field circuit.

The same board can be used for 3 phase field exciters without modification.

The current measurement is adjusted by TYPECODE parameter 97.01 and automatic adjusted by rated motor current setting.

## Field circuit interface

The On board field exciter is located internally. The firing pulses are synchronized from mains circuit L1, L2, L3 and SDCS-CON-4 board. The pulses are amplified on PIN4 board. The hardware structure is a three phase half controlled bridge supplied direct from mains circuit U1, V1, W1 via fuses F100, F101, F102.

If the On board field exciter is not needed it can be switched OFF by firmware.

The function of field circuit interface consists of:

- Firing the field bridge three phase half controlled bridge.
- Measurement of DC field current, the scaling is automatically selected via rated motor field current.
- Snubber circuit are shared with armature bridge.
- Fuses F100, F101, F102 for cable and motor field protection.
- 600 V converter are always without Onboard field exciter

### Ratings

AC voltage range	110...500 V (525 V)
AC insulation voltage	500 V
Frequency	50 Hz / 60Hz
AC input current	< field current
Minimum Current	300 mA

Size	D1	D2	D3	D4
DC output current	6A	15A	20A	25A
max. cross sectional area	6 mm <sup>2</sup> AWG 10	6 mm <sup>2</sup> AWG 10	6 mm <sup>2</sup> AWG 10	6 mm <sup>2</sup> AWG 10
min. cross sectional area	1 mm <sup>2</sup> AWG 16	2.5 mm <sup>2</sup> AWG 13	4 mm <sup>2</sup> AWG 11	6 mm <sup>2</sup> AWG 10
Fuse type	KTK - 25			



## Power Interface SDCS-PIN-46/SDCS-PIN-48/SDCS-PIN-5x

The Power Interface of DCS converter modules model D5/D6/D7 from 900 A up to 5200 A consists of two boards - the measuring board SDCS-PIN-51 and the pulse transformer board SDCS-PIN-48.

The following figures show the different connections between the SDCS-PIN-48 and SDCS-PIN-51 board depending on the application 2- or 4-quadrant and the construction type.

The firing board SDCS-PIN-46 is used for converters DCS800-S02-2500, DCS800-S02-3000 double bridge D6 modules.

2-Quadrant application, no parallel thyristors - Construction type D5/D6/D7

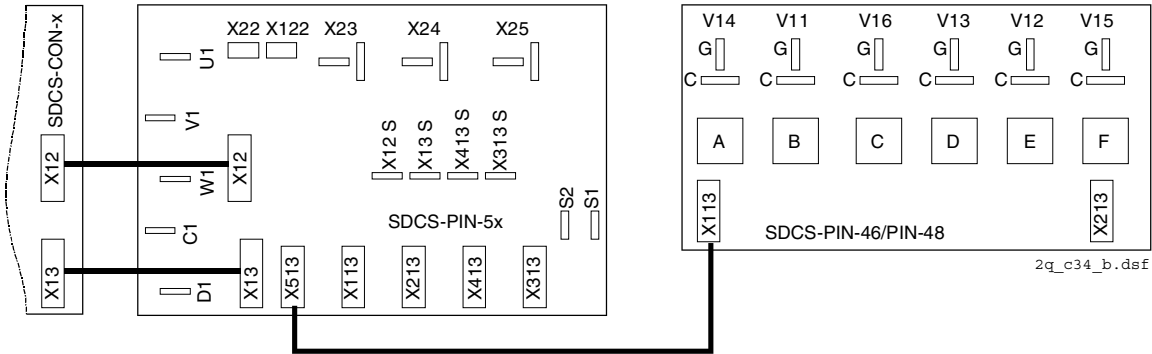

4-Quadrant application, no parallel thyristors - Construction type D5/D6/D7

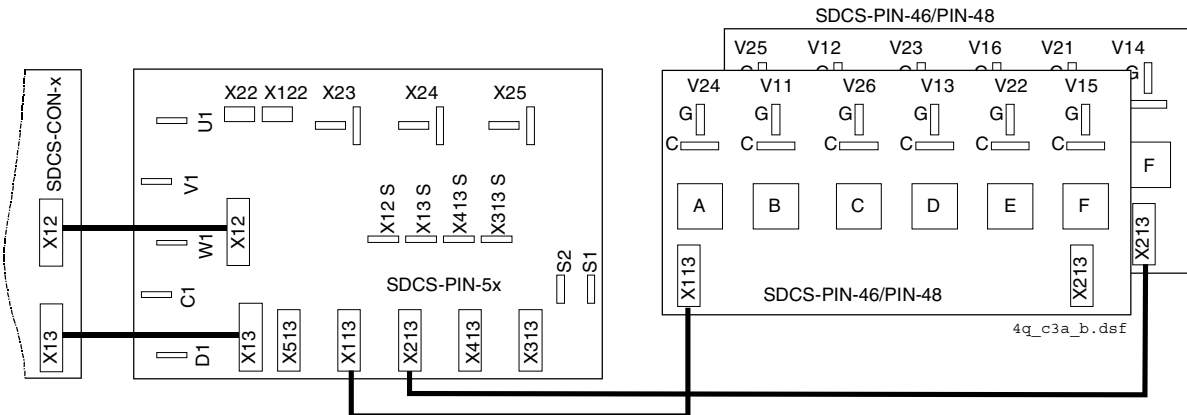

Pulse transformer board SDCS-PIN-46/PIN-48

Layout of the SDCS-PIN-46/PIN-48 pulse transformer board

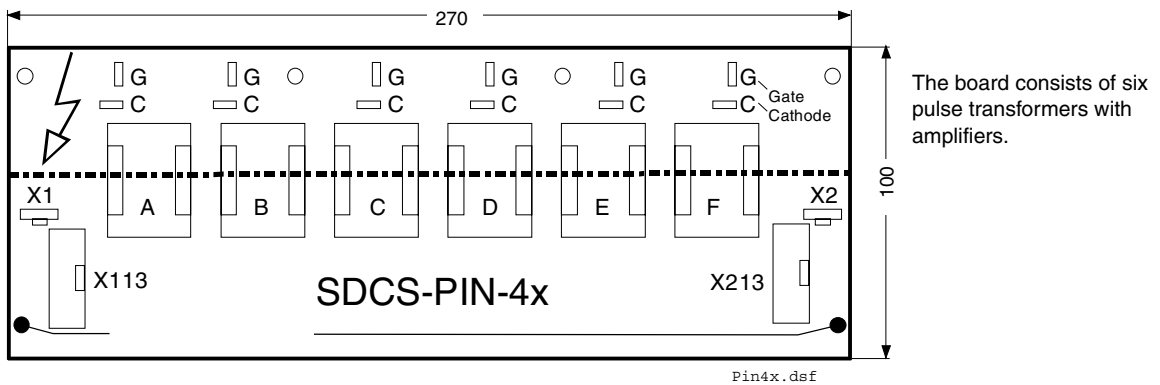

**Measuring board SDCS-PIN-51**

This board is always used together with SDCS-PIN-4x board. On this board there are the circuits located needed for current, voltage and temperature measuring and for hardware coding.

The current is measured by current transformers at the main AC inputs, rectified by a diode bridge and scaled with burden resistors. The nominal current is adjusted by cutting out resistors (R1 ... R21) from the board according to the current coding table. The resistors R22 ... R26 are used for the current equal to zero detection. These resistors must be cut off too, according to the current coding table. Voltages (U1, V1, W1 and C1(+) and D1(-)) are measured by using high ohm resistor chains. Scaling of AC and DC voltage is done by activating 1 MΩ resistors (= cutting out short circuit wires, which are represented by low ohmic resistors).

The voltage measurement uses 5 resistor:

- U1:W1 to W5
- V1:W6 to W11
- W1:W12 to W16
- C1(+):W17 to W21
- D1(-):W22 to W26

If there is a need for voltage adaptation, all 5 chains must be handled in the same way.

**Note!** Actual voltage signals U1, V1, W1, C1(+) and D1(-) of the main circuit are not galvanically isolated from the control board. Because of that a current of less than 1 mA will flow to earth. When galvanically isolated measurement is needed, please contact your ABB representative..

Layout of the SDCS-PIN-51 board

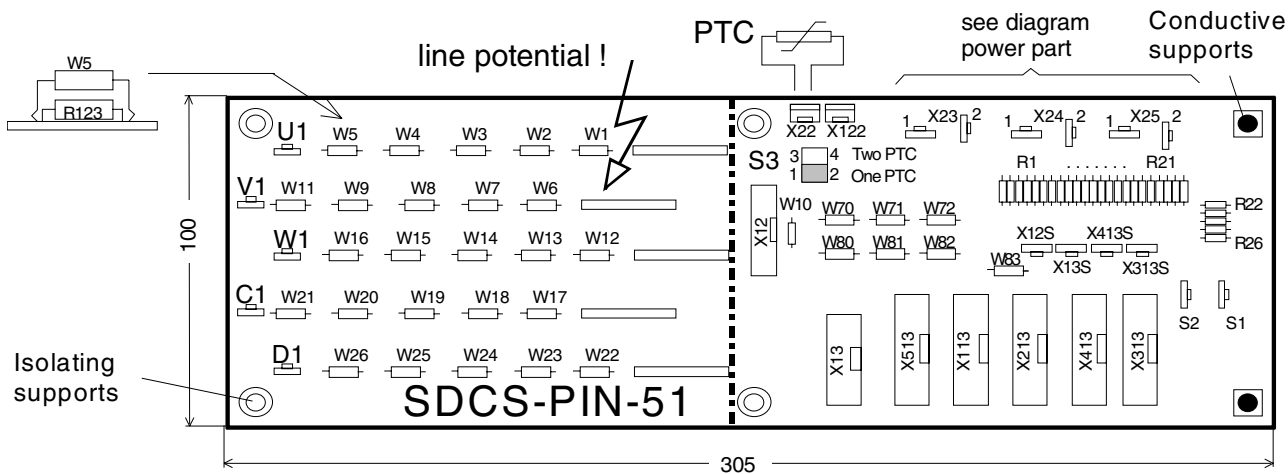

Settings of the SDCS-PIN-51 board if a DCS converter is equipped with it by ABB

**Current coding**

Construction type		D5				D6				D7					
Current transf. ratio		2500:1				2500:1				4000:1					
Rated current [A DC]		900	1200	1500	2000	1900	2050	2500	3000	2050	2600	3300	4000	4800	5200
R1-R4	18 Ω	○—○	○—○	○—○	○—○	○—○	○—○	○—○	○—○	○—○	○—○	○—○	○—○	○—○	○—○
R5	18 Ω	○—○	○—○	○—○	○—○	○—○	○—○	○—○	○—○	○—○	○—○	○—○	○—○	○—○	○—○
R6	18 Ω	○—○	○—○	○—○	○—○	○—○	○—○	○—○	○—○	○—○	○—○	○—○	○—○	○—○	○—○
R7	18 Ω	○—○	○—○	○—○	○—○	○—○	○—○	○—○	○—○	○—○	○—○	○—○	○—○	○—○	○—○
R8	18 Ω	○—○	○—○	○—○	○—○	○—○	○—○	○—○	○—○	○—○	○—○	○—○	○—○	○—○	○—○
R9	18 Ω	○—○	○—○	○—○	○—○	○—○	○—○	○—○	○—○	○—○	○—○	○—○	○—○	○—○	○—○
R10	18 Ω	○—○	○—○	○—○	○—○	○—○	○—○	○—○	○—○	○—○	○—○	○—○	○—○	○—○	○—○
R11	18 Ω	⊗×○	⊗×○	⊗×○	⊗×○	○—○	○—○	○—○	○—○	○—○	○—○	○—○	○—○	○—○	○—○
R12	18 Ω	⊗×○	⊗×○	⊗×○	⊗×○	○—○	○—○	○—○	○—○	○—○	○—○	○—○	○—○	○—○	○—○
R13	18 Ω	⊗×○	⊗×○	⊗×○	⊗×○	○—○	○—○	○—○	○—○	○—○	○—○	○—○	○—○	○—○	○—○
R14	18 Ω	⊗×○	⊗×○	⊗×○	⊗×○	○—○	○—○	○—○	○—○	○—○	○—○	○—○	○—○	○—○	○—○
R15	18 Ω	⊗×○	⊗×○	⊗×○	⊗×○	○—○	○—○	○—○	○—○	○—○	○—○	○—○	○—○	○—○	○—○
R16	18 Ω	⊗×○	⊗×○	⊗×○	⊗×○	○—○	○—○	○—○	○—○	○—○	○—○	○—○	○—○	○—○	○—○
R17	33 Ω	⊗×○	⊗×○	⊗×○	⊗×○	○—○	○—○	○—○	○—○	○—○	○—○	○—○	○—○	○—○	○—○
R18	68 Ω	⊗×○	⊗×○	⊗×○	⊗×○	○—○	○—○	○—○	○—○	○—○	○—○	○—○	○—○	○—○	○—○
R19	120 Ω	⊗×○	⊗×○	⊗×○	⊗×○	○—○	○—○	○—○	○—○	○—○	○—○	○—○	○—○	○—○	○—○
R20	270 Ω	⊗×○	⊗×○	⊗×○	⊗×○	○—○	○—○	○—○	○—○	○—○	○—○	○—○	○—○	○—○	○—○
R21	560 Ω	⊗×○	⊗×○	⊗×○	⊗×○	○—○	○—○	○—○	○—○	○—○	○—○	○—○	○—○	○—○	○—○
R22	47 Ω	○—○	○—○	○—○	○—○	○—○	○—○	○—○	○—○	○—○	○—○	○—○	○—○	○—○	○—○
R23	47 Ω	○—○	○—○	○—○	○—○	○—○	○—○	○—○	○—○	○—○	○—○	○—○	○—○	○—○	○—○
R24	47 Ω	○—○	○—○	○—○	○—○	○—○	○—○	○—○	○—○	○—○	○—○	○—○	○—○	○—○	○—○
R25	47 Ω	○—○	○—○	○—○	○—○	○—○	○—○	○—○	○—○	○—○	○—○	○—○	○—○	○—○	○—○
R26	100 Ω	○—○	○—○	○—○	○—○	○—○	○—○	○—○	○—○	○—○	○—○	○—○	○—○	○—○	○—○

code\_tab\_PIN1\_PIN20\_PIN51\_e.dsf

**Voltage coding**

Construction type	D5			D6 / D7				D7	D7
Conv. nom. voltage [V] ① U1 [V AC]	Y=4 (400V) Y=5 (500V)	Y=6 (600V)	Y=7 (690V)	Y=4 (400V) Y=5 (500V)	Y=6 (600V)	Y=7 (690V)	Y=8 (800V)	Y=9 (990V)	Y=1 (>1000V)
Voltage measurement scaled by type code parameter selection	500 V	600 V	690 V	500 V	600 V	690 V	800 V	1000 V	
Measuring board SDCS	PIN-51	PIN-51	PIN-51	PIN-51	PIN-51	PIN-51	PIN-51	PIN-51	see chapter Galvanic isolation
W1, 6, 12, 17, 22	○—○	⊗×○	⊗×○	○—○	⊗×○	⊗×○	⊗×○	⊗×○	
W2, 7, 13, 18, 23	○—○	○—○	⊗×○	○—○	○—○	⊗×○	⊗×○	⊗×○	
W3, 8, 14, 19, 24	○—○	○—○	○—○	○—○	○—○	○—○	⊗×○	⊗×○	
W4, 9, 15, 20, 25	○—○	○—○	○—○	○—○	○—○	○—○	○—○	⊗×○	
W5, 11, 16, 21, 26	○—○	○—○	○—○	○—○	○—○	○—○	○—○	⊗×○	

① the converters can be used at lower line voltage than specified by the y-value without hardware modifications, if the nominal line voltage applied to the converter is not lower than 45% for y=5...9 and not lower than 55% for y=4.

<p><b>Temp. sensor coding</b></p> <p>R 57 as a temp. sensor for D5, D6, D7</p> <p>S3</p>	<p style="text-align: center;">don't care</p> <p>W10</p>
<p><b>Board used as a spare part:</b></p> <ul style="list-style-type: none"> <li>default: all jumpers Wxx, Rxx are in ○—○ condition</li> <li>ensure the correct converter type related settings</li> </ul>	<p style="text-align: center;">indicates a removed jumper</p> <p style="text-align: center;">⊗×○</p>



Typical armature circuit thyristor converter diagram with SDCS-PIN-48 and SDCS-PIN-51 boards for a 4-Quadrant D7 type converter

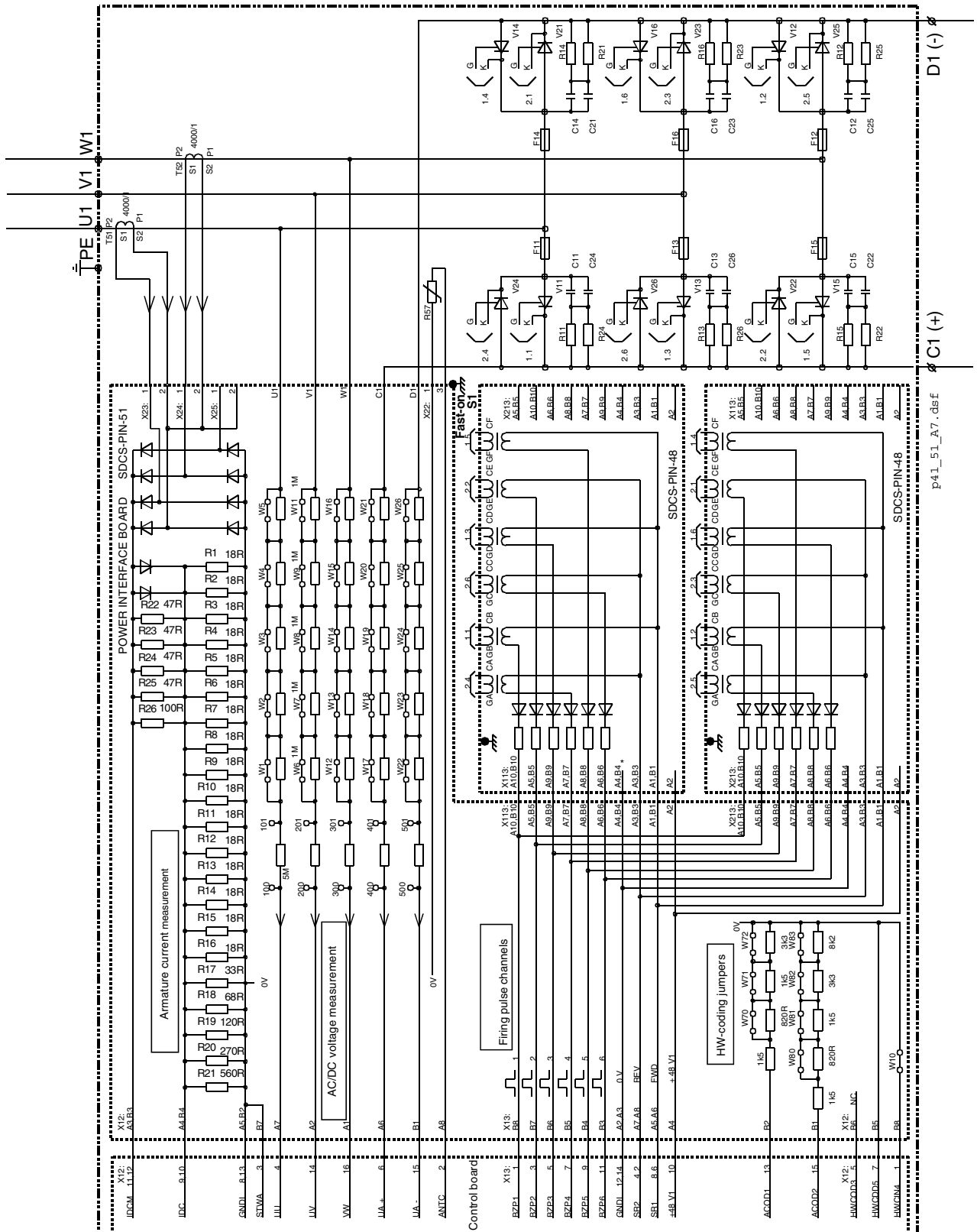

# Interface Board SDCS-SUB-4

## General

On SDCS-PIN-4 and SDCS-PIN-51 the line voltage and DC voltage measurement is done by high ohmic resistors typical 5 M ohm for 500 V units.

Voltages below 100 V line voltage must be adapted by smaller resistance and rescaled measurement channel. Such rescaling provide improved mains synchronization and DC measurement resolution at small voltage.

SDCS-SUB-4 board provides a different scaling of voltage measurement. The default selection is 1.17 Mohm with maximum mains voltage of 120 V. The maximum measurement voltage scale is 200 V. Adjust voltage scaling parameter according to table below.

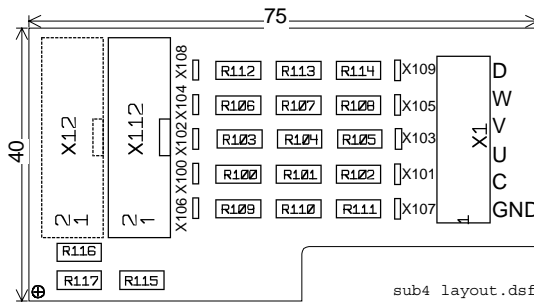

Mains voltage	chain R <sub>C</sub> ...R <sub>D</sub>	Setting 97.03	Size
30...120 V	appr. 1.17 MOhm	117 V	D1...D4
A92/T90 (600V)	27.4 kOhm	0 V	D1...D4

Example: chain R<sub>C</sub>=R109+R110+R111

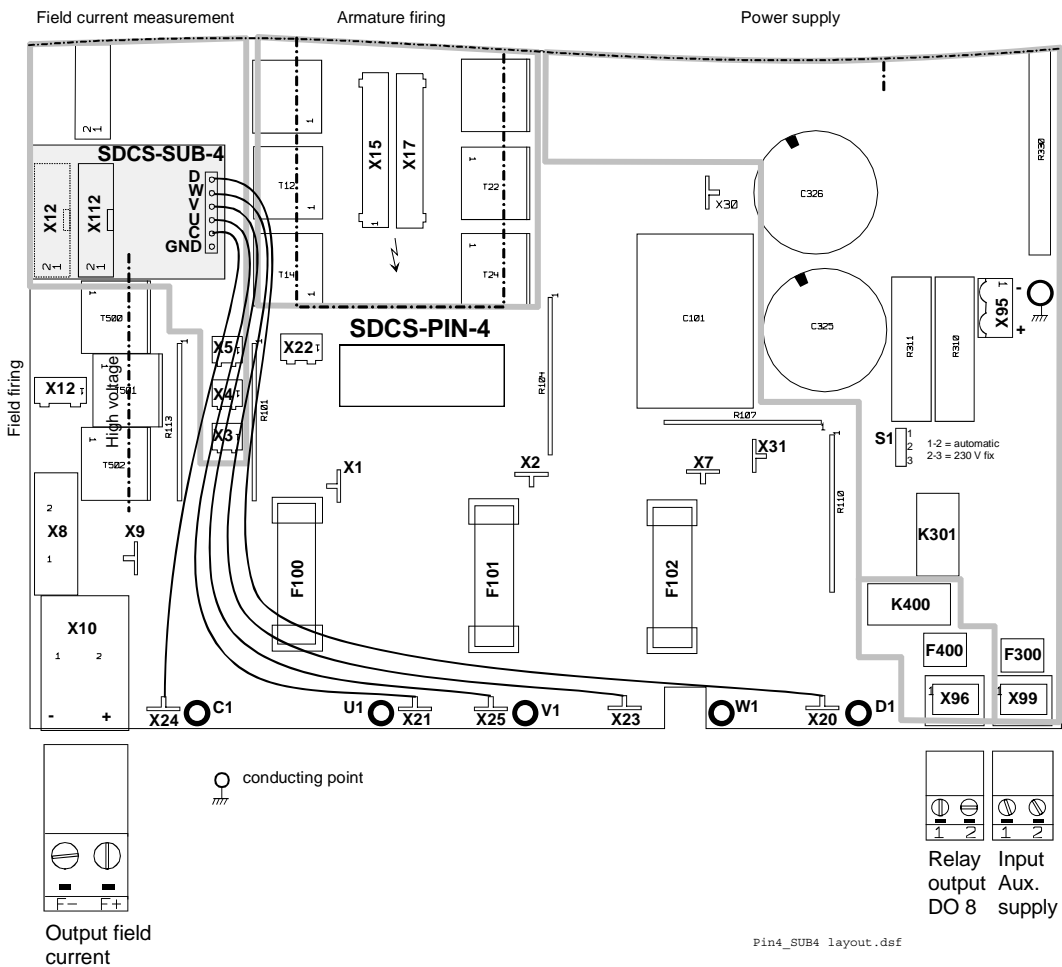

Layout of SDCS-SUB-4 and location on SDCS-PIN-4

Typical armature circuit thyristor converter diagram with SDCS-PIN-4 and SDCS-SUB-4 board

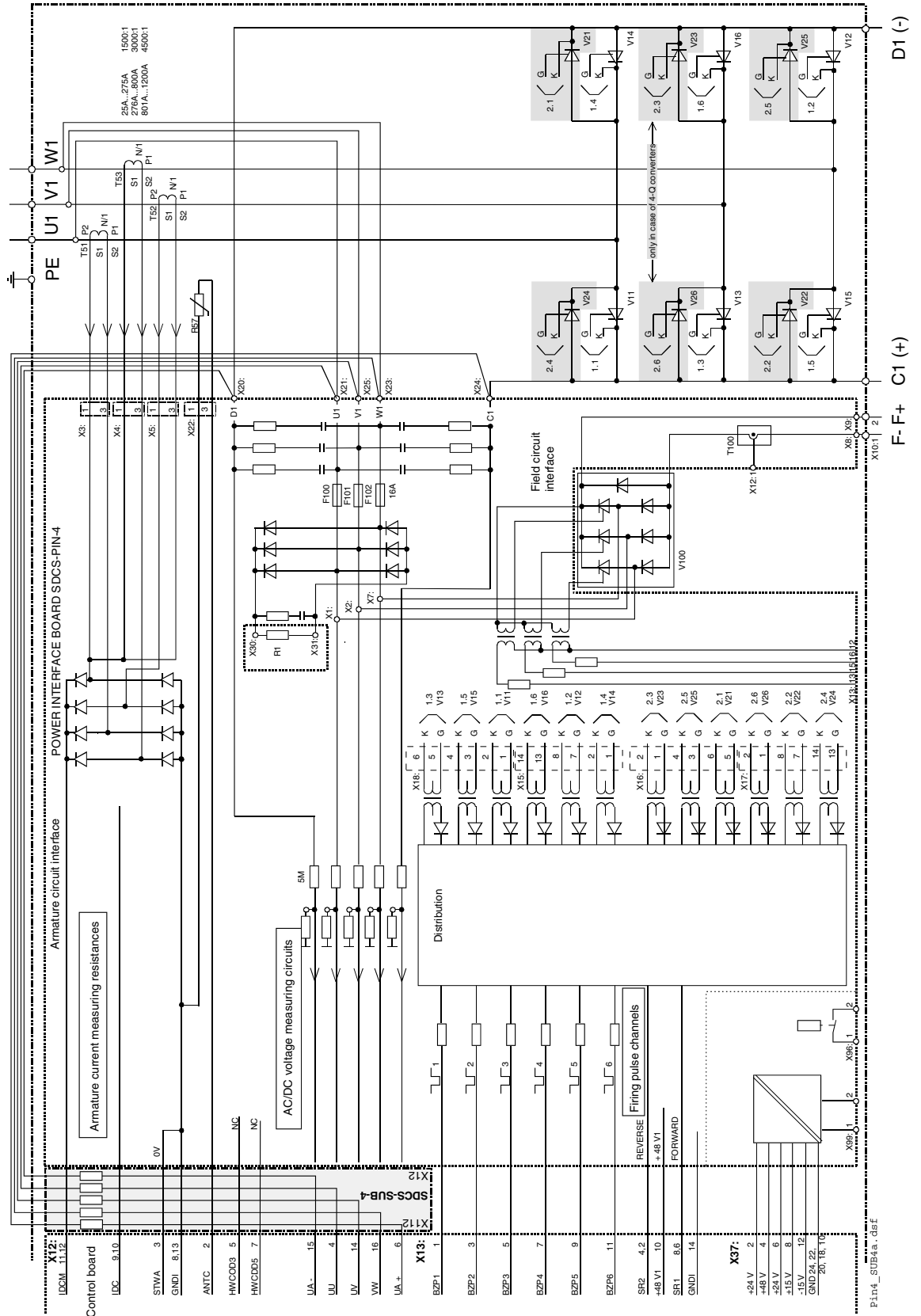

## Galvanic isolation - T90, A92

The Galvanic isolation is an option for converters in the current range 2050...5200 A DC and rated voltages  $\leq 1000$  V. For converters with a rated AC voltage of 1190 V and 12-pulse serial  $> 2 \times 500$  V the galvanic isolation is a standard equipment. It is used to replace the high-ohmic resistance voltage measurement and gives the advantage of a total isolation from power part to electronic part.

The transformer T90 and the DC transducer A92 are located outside the converter module. The internal AC and DC voltage measurement channels are opened and connected to the T90 and A92 units.

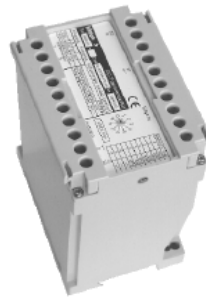

8601A1

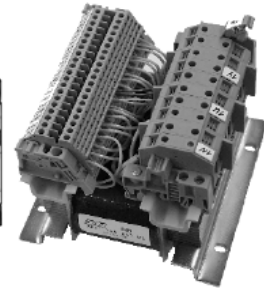
42000D3  
42001D3

3ADT 745047

Hard and software settings:

Voltage coding on measuring board						
Construction type	D5 / D6 / D7					
Conv. nom. voltage [V] *	Y=4 (400V) Y=5 (500V)	Y=6 (600V)	Y=7 (690V)	Y=8 (800V)	Y=9 (990V)	Y=1 (1200V)
Rated mains voltage [V AC]	220...500	270...600	300...690	350...800	450...990	530...1200
Value f. conv. nom. volt at SET(TINGS) block *	500	600	690	800	990	1200
Measuring board SDCS-	<b>PIN-51</b>	<b>PIN-51</b>	<b>PIN-51</b>	<b>PIN-51</b>	<b>PIN-51</b>	<b>PIN-51</b>
Resistors W1...W26						
	all resistors are 0 $\Omega$					
Galvanic isolation						
Resistors Rx on PIN51	27.4 k $\Omega$	27.4 k $\Omega$	27.4 k $\Omega$	27.4 k $\Omega$	27.4 k $\Omega$	27.4 k $\Omega$
DC-DC transducer <b>A92</b>	<b>8680A1</b>					
Switch position R <sub>G</sub> *	<b>7</b> (675 V)	<b>6</b> (810 V)	<b>5</b> (945 V)	<b>4</b> (1080 V)	<b>2</b> (1350 V)	<b>1</b> (1620 V)
DC-DC transducer <b>A92</b>	<b>42000D3</b>					
Switch position R <sub>G</sub> *	x	<b>C</b> (0.8 kV)	<b>D</b> (1 kV)	x	x	x
DC-DC transducer <b>A92</b>	<b>42001D3</b>					
Switch position R <sub>G</sub> *	x	x	x	x	<b>A</b> (1.4 kV)	<b>B</b> (1.6 kV)
Transformer <b>T90</b>	<b>3ADT 745047</b>					
Secondary Terminals *	2U1 2V1 2W1 2N	2U2 2V2 2W2 2N	2U3 2V3 2W3 2N	2U4 2V4 2W4 2N	2U5 2V5 2W5 2N	2U6 2V6 2W6 2N

\* 12-pulse serial and sequential have a different selection between **SConvScaleVolt (97.03)** and the scaling of measurement channel. See *12-pulse manual for DCS 800*.

Typical armature circuit thyristor converter diagram with SDCS-PIN-48 and SDCS-PIN-51 boards for a 4-Q D7 type converter with galvanic isolation

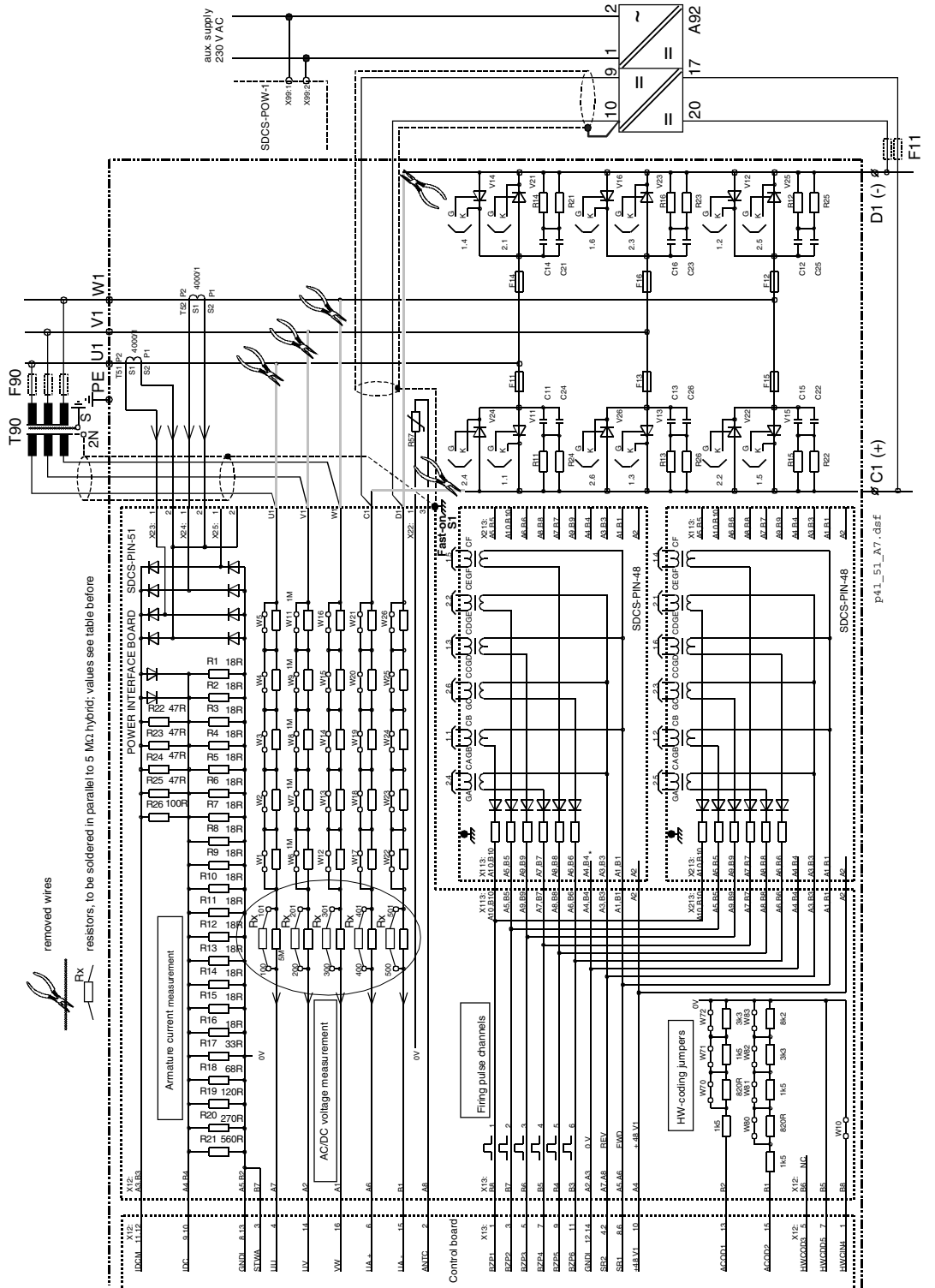

### DC-DC transducer A92

Principle circuit diagram of the DC-DC transducer A92

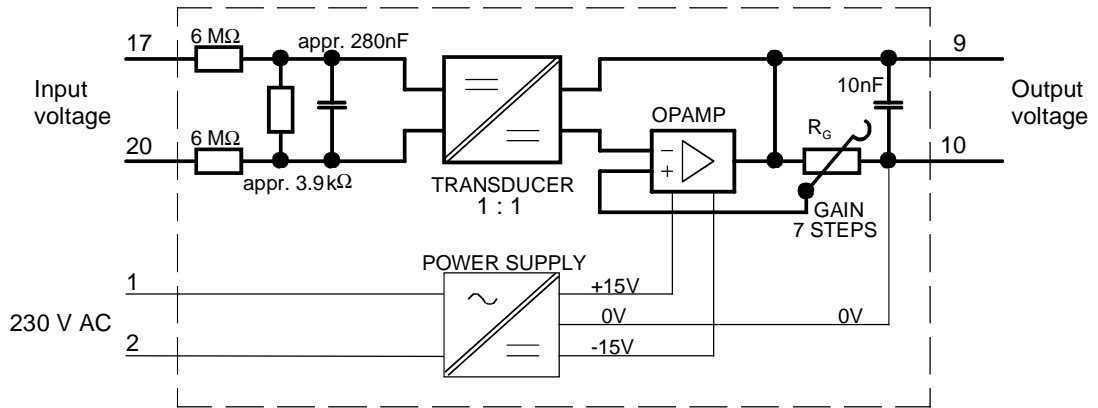

#### Data

Selectable voltage gains:	675	810	945	1080	1215	1350	1620	V DC
Switch position	7	6	5	4	3	2	1	

- Output voltage: 9,84 V / 5 mA
- Auxiliary power: 230 V ± 15 %; 50/60 Hz; 3 W
- Clearance in air: Auxiliary power to Output: >13 mm  
Input/Output to Auxiliary power: >14 mm
- Insulation voltage: 2000 V
- Insulation test voltage: 5000 V
- Ambient temperature range: - 10 ...+ 70 °C
- Weight: appr. 0.4 kg

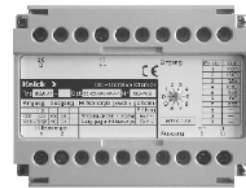

The voltage gain and frequency response is especially designed for DCS800 converters.

#### Dimensions in mm

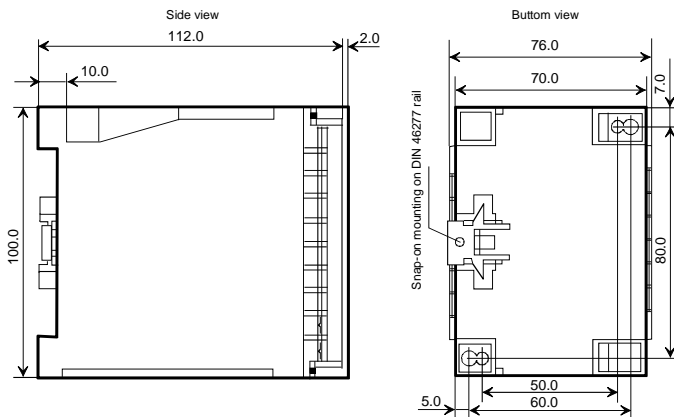

#### Location of terminals

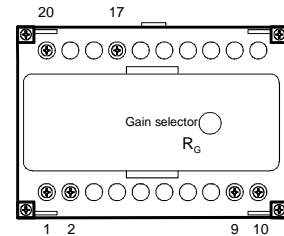

## Transformer T90

Principle diagram of the transformer T90

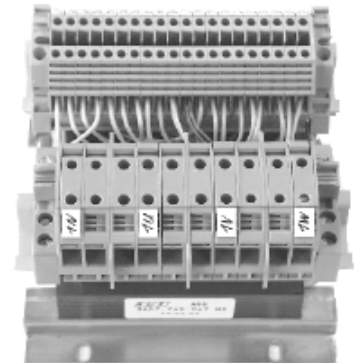
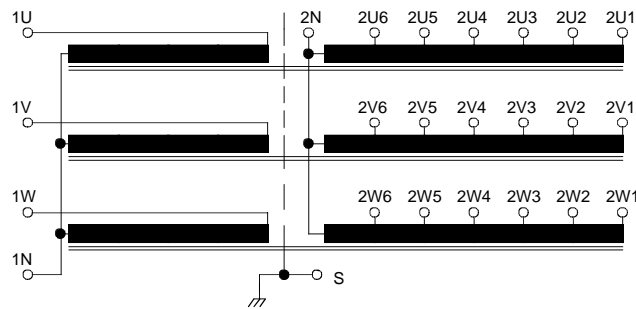

### Data

Selectable transfer ratios $U_{prim}$ :	502, 601, 701, 800, 1000, 1200 V AC rms
Output voltage:	7.3 V AC rms
Insulation voltage:	1200 V
Isolation test voltage:	3500 V
Ambient temperature range:	- 10 ...+ 70 °C
Weight:	- 10 ...+ 70 °C
Weight:	2.1 kg

### Dimensions in mm

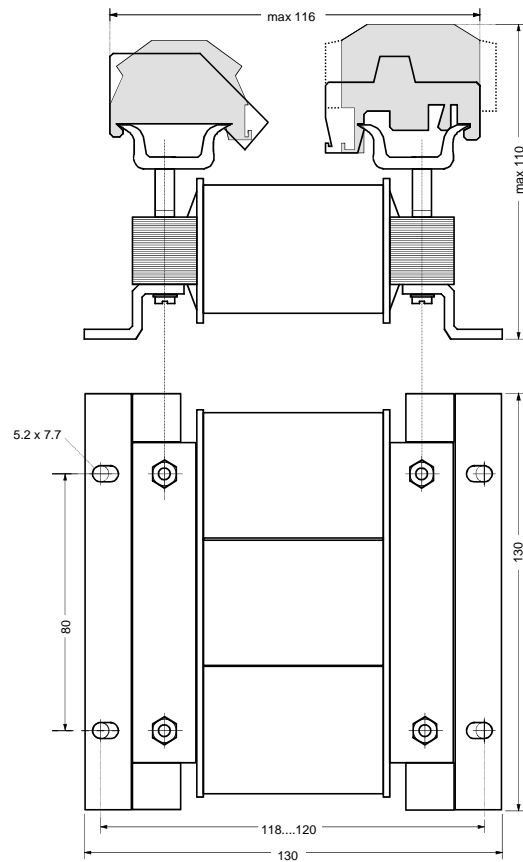

### Remark

The terminals on the primary side of the transformer are in special design (lug terminals).

Handling hints: First turn the screw counter-clockwise to the end stop, then swing out the shrouding cover. Put in the cable lug, swing in the shrouding cover and fasten the connection by turning the screw clockwise.

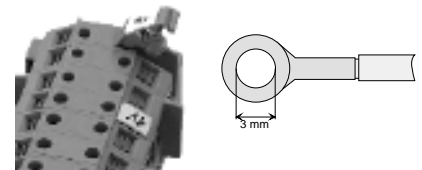





# Dimensional drawings

Dimensional drawings of the DCS800 are shown below. The dimensions are given in millimeters.

## Module D1

- DCS800-S01-0020
- DCS800-S01-0045
- DCS800-S01-0065
- DCS800-S01-0090
- DCS800-S01-0125

- DCS800-S02-0025
- DCS800-S02-0050
- DCS800-S02-0075
- DCS800-S02-0100
- DCS800-S02-0140

## Module D2

- DCS800-S01-0180
- DCS800-S01-0230

- DCS800-S02-0200
- DCS800-S02-0260

## Module D3

- DCS800-S01-0315
- DCS800-S01-0405
- DCS800-S01-0470

- DCS800-S02-0350
- DCS800-S02-0450
- DCS800-S02-0520

## 600 V types

- DCS800-S01-0290
- DCS800-S02-0320

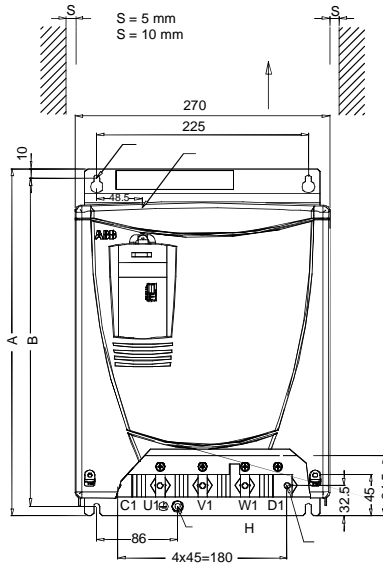

Größe	A	B	C	D	E	F	G	H	Gewicht
D1	370	350	142	200	67	98	145	M6	ca. 11kg
D2	370	350	209	267	121,5	163,5	212	M10	ca. 16kg
D3	459	437,5	262,5	310	147,5	205	252	M10	ca. 25kg

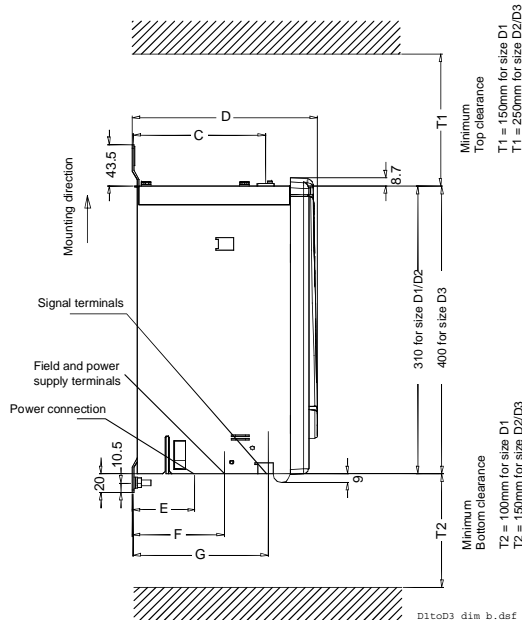

## Module D4

DCS800-S01-0610  
 DCS800-S01-0740  
 DCS800-S01-0900

DCS800-S02-0680  
 DCS800-S02-0820  
 DCS800-S02-1000

### 600 V types

DCS800-S01-0590  
 DCS800-S02-0650

Weight appr. 38 kg

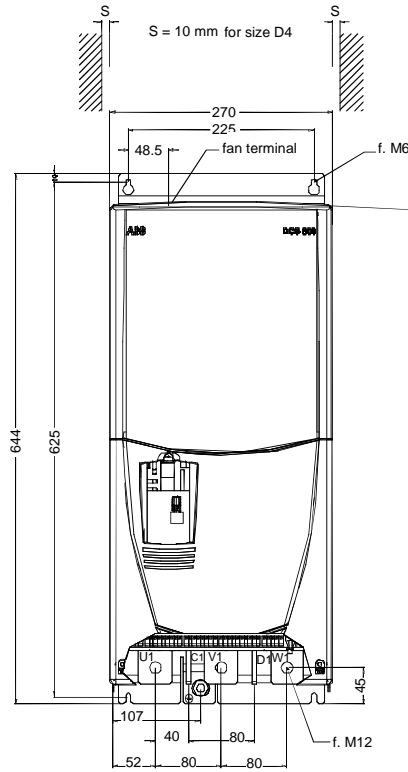

Power terminal: Busbar 40x5 mm  
 Weight appr. 38 kg

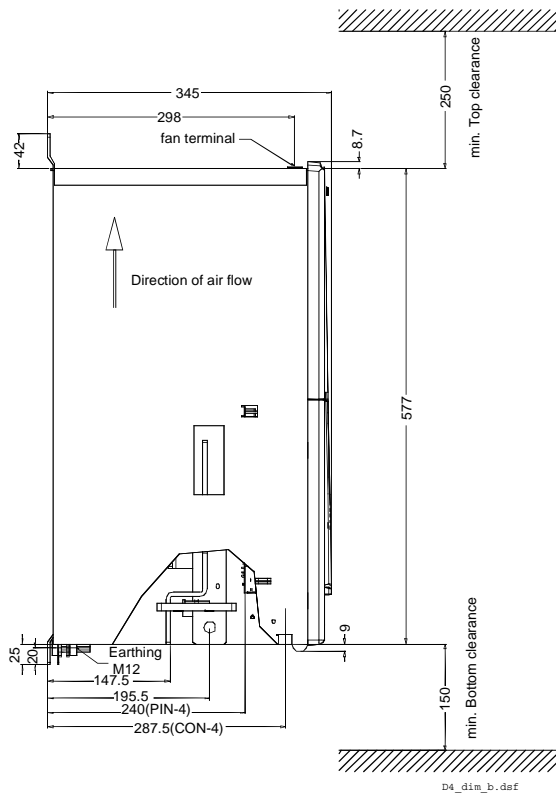

D4\_dim\_b.dwg

## Module D5

DCS800-S0x-0900  
 DCS800-S0x-1200  
 DCS800-S0x-1500  
 DCS800-S0x-2000

Weight appr. 110 kg

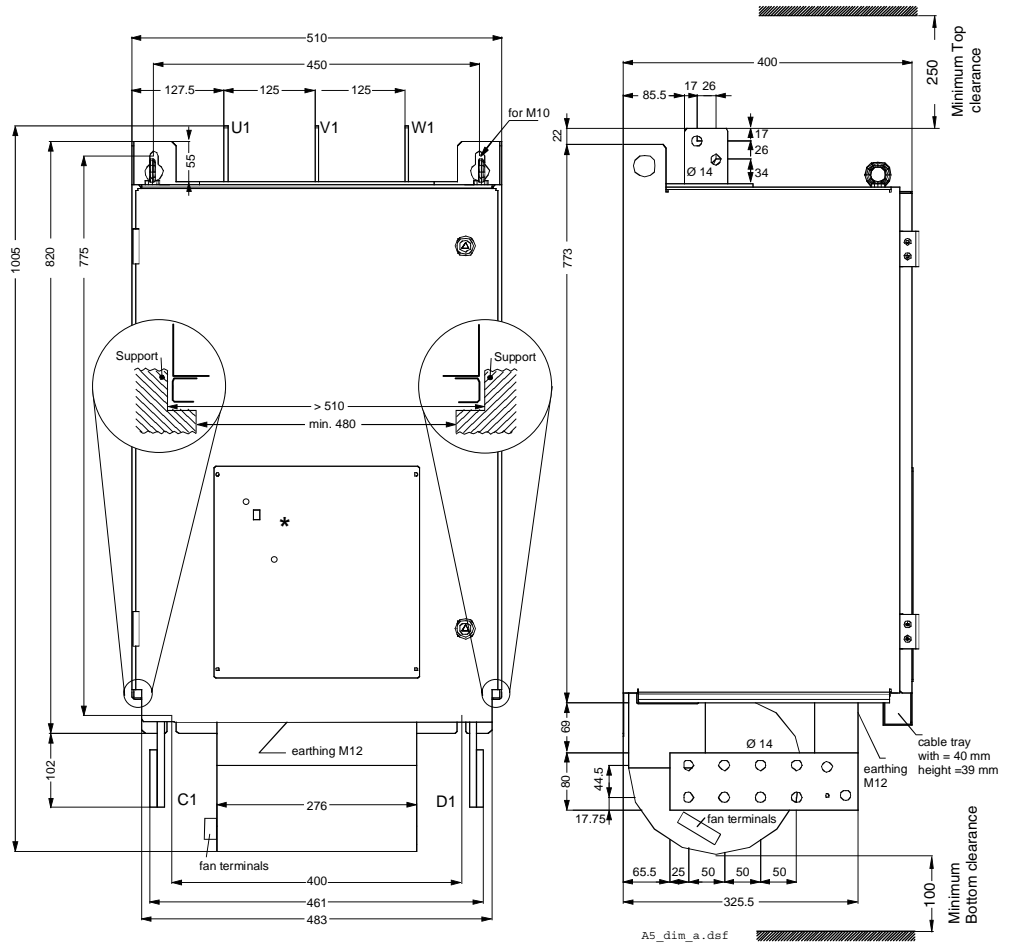

Busbars in mm:  
**DC 80 x 10**  
**AC 60 x 5**

### Mounting the converter module D5 inside an enclosure

Two supports should be mounted inside the enclosure in such a way, that they can carry the converter's weight when placing the converter later on. The minimum distance between the supports should not be less than 480 mm because of electrical clearance (DC busbars).

An L-shape support as indicated will allow to place the converter temporarily close to the front end of the support (weight still taken by a lifting device) and then push it back to the back plate of the enclosure. The upper and lower holes in the back plate of the converter should be used to fix the converter in that position.

### Module D6

- DCS800-S0x-1900
- DCS800-S0x-2050
- DCS800-S0x-2500
- DCS800-S0x-3000

Weight appr. 180 kg

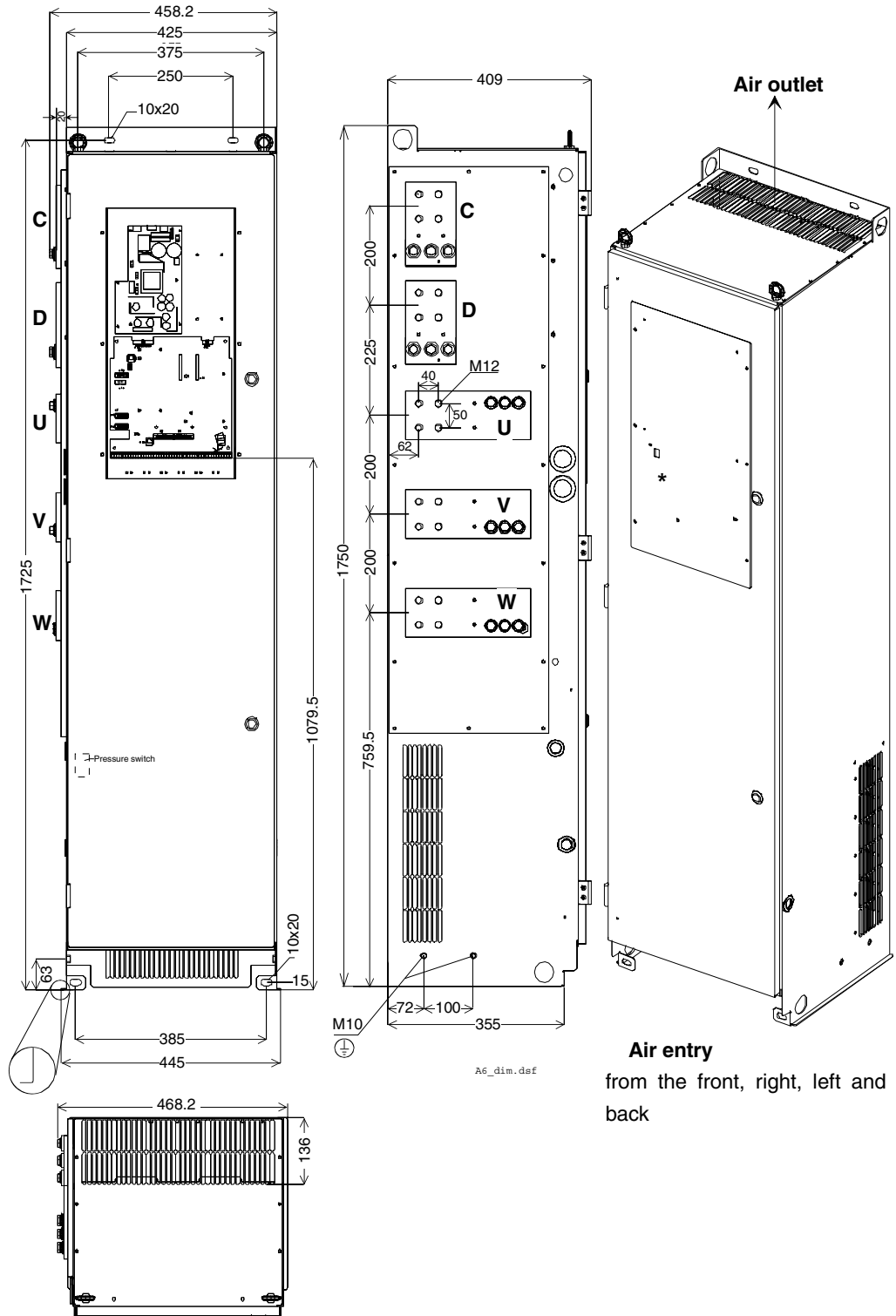



## Module D7 right-hand

DCS800-S0x-2050-xxR  
 DCS800-S0x-2600-xxR  
 DCS800-S0x-3300-xxR  
 DCS800-S0x-4000-xxR  
 DCS800-S0x-4800-xxR  
 DCS800-S0x-5200-xxR

Weight appr. 315 kg

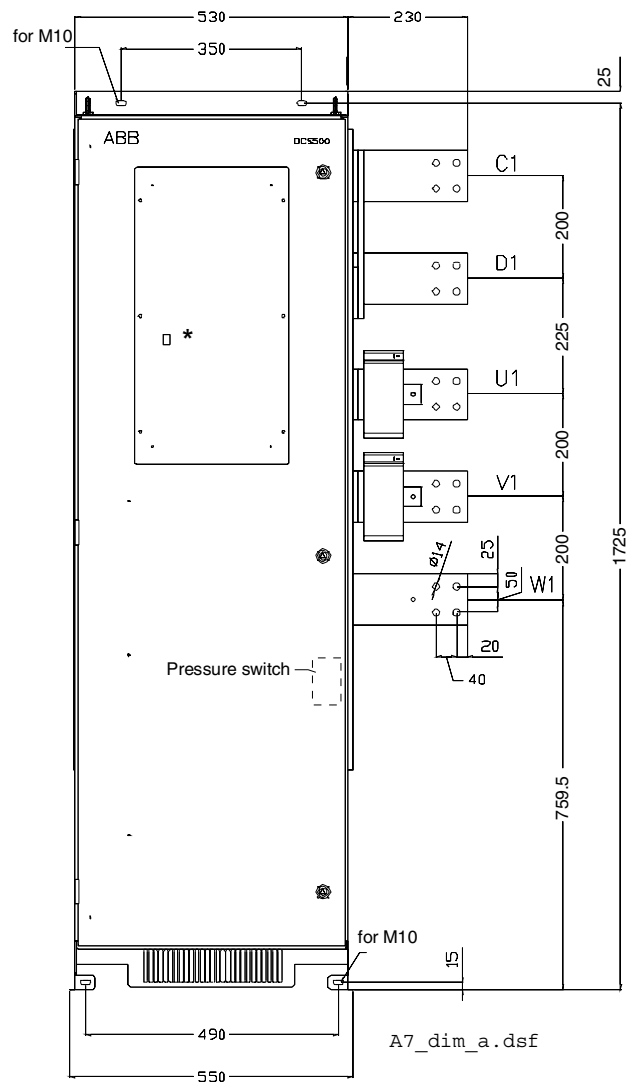
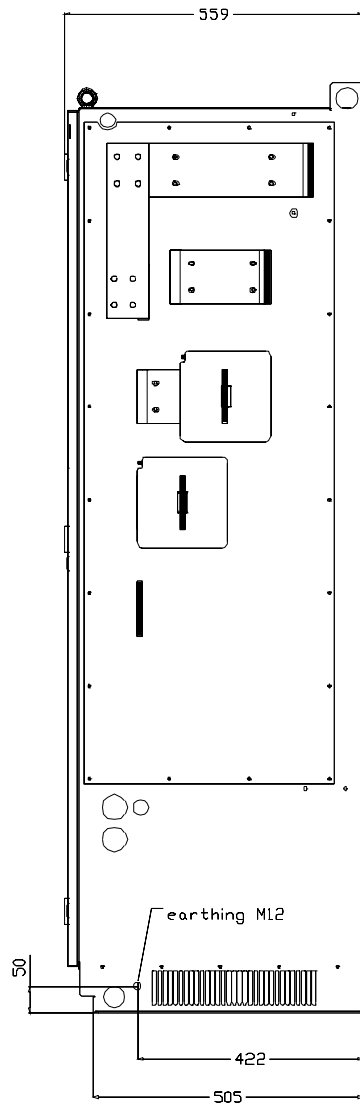

Busbars in mm:  
**AC and DC 100 x 10**

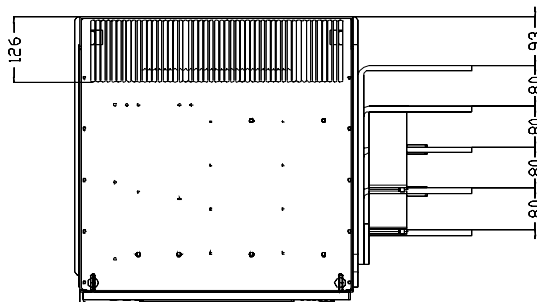

## Fuses installed inside the converter

Converter type	Model	Fuse F1	Size	Type
<b>400 V / 500 V</b>				
DCS800-S0x-1200-04/05	D5	800A 660V UR	5	170M 6162
DCS800-S0x-1500-04/05	D5	1250A 660V UR	5	170M 6166
DCS800-S0x-2000-04/05	D5	1600A 660V UR	5	170M 6169
DCS800-S0x-2050-51	D6	1500A 660V UR	5	170M 6168
DCS800-S0x-2500-04/05	D6	900A 660V UR ①	5	170M 6163
DCS800-S01-3000-04/05	D6	1250A 660V UR ①	5	170M 6166
DCS800-S02-3000-04/05	D6	1250A 660V UR ①	5	170M 6166
DCS800-S0x-3300-04/05	D7	2500A 660V UR	7	170M 7026
DCS800-S0x-4000-04/05	D7	3000A 660V UR	7	170M 7028
DCS800-S0x-5200-04/05	D7	3500A 660V UR	7	170M 7057
<b>600 V / 690 V</b>				
DCS800-S0x-0900-06/07	D5	630A 1250V UR	6	170M 6144
DCS800-S0x-1500-06/07	D5	1100A 1250V UR	6	170M 6149
DCS800-S01-2000-06/07	D5	1400A 1100V UR	6	170M 6151
DCS800-S0x-2050-06/07	D6	700A 1250V UR ①	6	170M 6145
DCS800-S0x-2500-06/07	D6	1000A 1250V UR ①	6	170M 6148
DCS800-S01-3000-06/07	D6	1100A 1250V UR ①	6	170M 6149
DCS800-S02-3000-06/07	D6	1100A 1250V UR ①	6	170M 6149
DCS800-S0x-3300-06/07	D7	2500A 1000V UR	8	170M 7036
DCS800-S0x-4000-06/07	D7	3000A 1000V UR	8	170M 7156
DCS800-S0x-4800-06/07	D7	3000A 1000V UR	8	170M 7156
<b>790 V</b>				
DCS800-S0x-1900-08	D6	700A 1250V UR ①	6	170M 6145
DCS800-S0x-2050-08	D6	700A 1250V UR ①	6	170M 6145
DCS800-S0x-2500-08	D6	1000A 1250V UR ①	6	170M 6148
DCS800-S01-3000-08	D6	1100A 1250V UR ①	6	170M 6149
DCS800-S02-3000-08	D6	1100A 1250V UR ①	6	170M 6149
DCS800-S0x-3300-08	D7	2500A 1000V UR	8	170M 7036
DCS800-S0x-4000-08	D7	3000A 1000V UR	8	170M 7156
DCS800-S0x-4800-08	D7	3000A 1000V UR	8	170M 7156
<b>1000 V</b>				
DCS800-S0x-2050-10	D7	1800A 1250V UR	9	170M 7976
DCS800-S0x-2600-10	D7	1800A 1250V UR	9	170M 7976
DCS800-S0x-3300-10	D7	2500A 1250V UR	9	170M 7978
DCS800-S0x-4000-10	D7	2500A 1250V UR	9	170M 7978

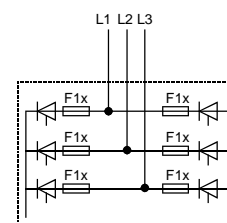

① 12 fuses per bridge (2x per F1x)

**Size 5, 6**

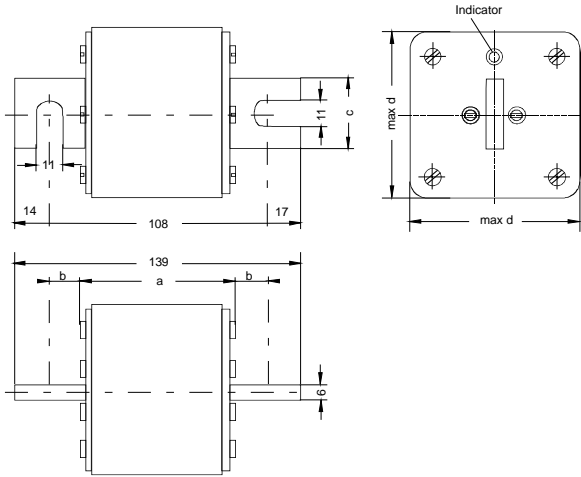

Size	a	b	c	d
5	50	29	30	76
6	80	14	30	76

**Size 7...10**

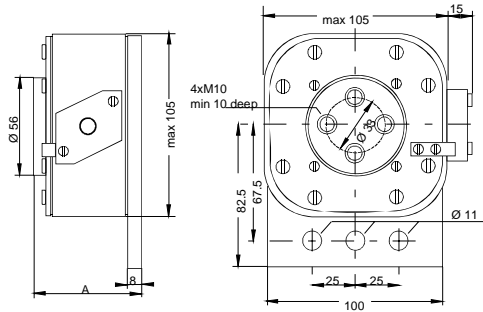

Size	A
7	62
8	90
9	105
10	120

**Remark:**

Given dimensions may be exceeded in some cases. Please take them only for information.

**Card holder for SDCS-IOB-2/3**

IOB assembly / mounting kit 3ADT783046

- card holder
  - finger protection cover
  - screen clamp
- (IOB-2x / IOB-3 not included)

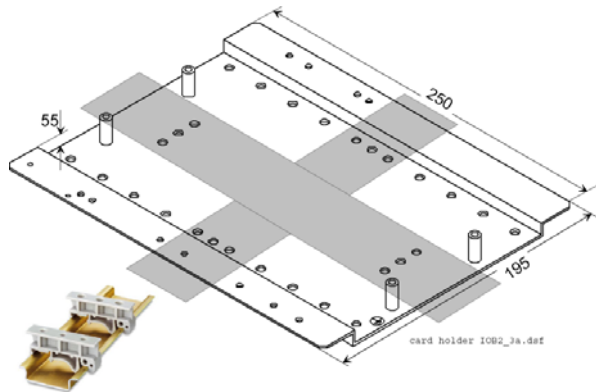
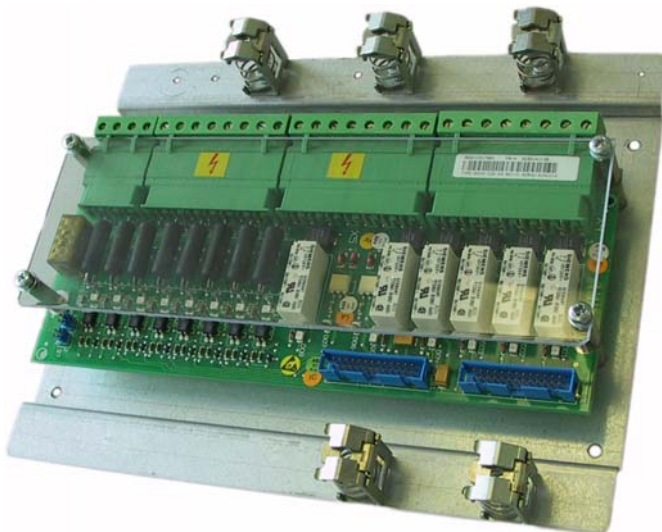

with universal Phoenix clamp 1202713 it is possible to mount the card holder on standard rail system in horizontally or vertically direction



# Accessories

## DCF803-0035 and FEX 425 internal

The field exciter DCF803-0035 and FEX425intern are half controlled three-phase field converter. Both field converters are based on the same controller board SDCS FEX4. The board is equipped with own synchronization and current control. The current measurement circuit is automatic scaled based on rated motor field current. The field exciter is fully controlled and monitored via serial communication from the armature converter.

The field exciter is prepared to operate as three phase as well as single phase converter. Single phase operation is provided with terminals U and W

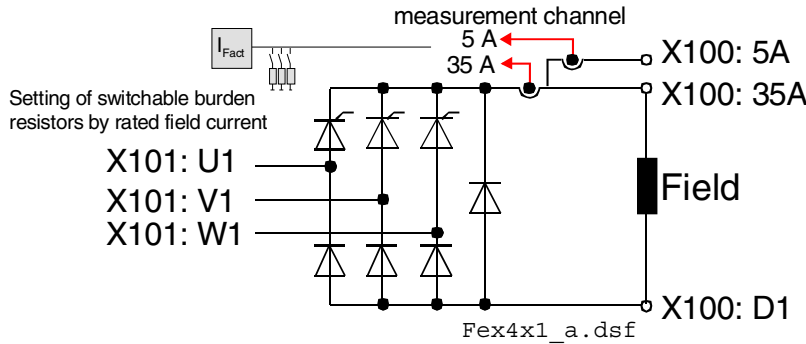

Layout of the SDCS-FEX-4 board

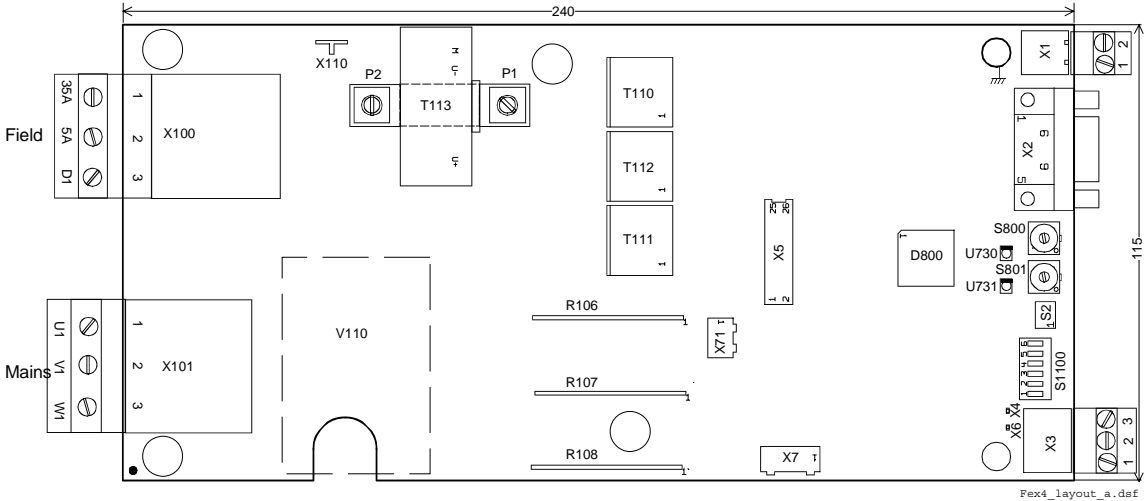

X1:	24 V supply
X1:1	24 V DC
X1:2	0 V DC

X3:	DSL Link
X3:1	GND B
X3:2	CAN L
X3:3	CAN H

## Electrical data

Power circuit	
AC Field input voltage	110 V -15%...500 V +10% single or three-phase
AC input current	< DC output current
Frequency	same as DCS Converter module
AC isolation voltage	600 V
Line reactor	external
Line fuses	KTK25 for FEX425 internal; external for DCF803-0035
DC output current *	300 mA (min)...25 A= FEX425 internal; ...35 A = DCF803-0035
Powerloss	< 130 W ( at rated current)
Auxiliary supply	
DC input voltage	24 V DC
Input current	< 200 mA supplied from SDCS-DSL-4 X51
Buffering	10ms

\* 3-phase or single phase operation

## Control unit

The control includes the following main blocks:

- Micro controller H8 for current control synchronization and fault handling.
- Two channel actual field current measurement of DC circuit.
- H8 controller for serial communication based on CAN standard.
- Driver circuit for firing of half control bridge.
- The software is stored in the flash PROM memory. This software contains
  - PI current control for field circuit
  - Fault and reset logic
  - Synchronization and PLL function
  - setting of current measurement channel

The setting and updating of all control parameters are set from armature converter via DCS link serial communication. Actual field current reference, current control and status bits are cyclic sent via DCS link serial communication.

The field exciter is equipped with an autoscaling function of burden resistor based on nominal field current of motor.

## Power section

The power section is a three-phase half controlled bridge with free-wheeling diode.

The external field exciter DCF803-0035 is the three-phase half controlled bridge including snubbers based on SDCS-FEX-4 board. Line fuses and the line reactor and transformer must be located outside the housing.

The internal field exciter FEX425 is a ready installed field exciter in a D5 armature converter. The unit is based on a SCDS-FEX-4 board and contains also line fuses. The supply must be connected by independant line reactors located outside of the D5 module, see drawing in chapter *The DCS800*, section *Armature circuit converter DCS800-S D5...D7*.

If the unit is used as a single phase supply the terminal U and W must be used. For single-phase supply an autotransformer for voltage adaptation is recommended.

Please see comparison of output voltage ripple between single-phase and three phase-supply.

Voltage ripple of  $U_{DC}$  voltage depending on operation modes

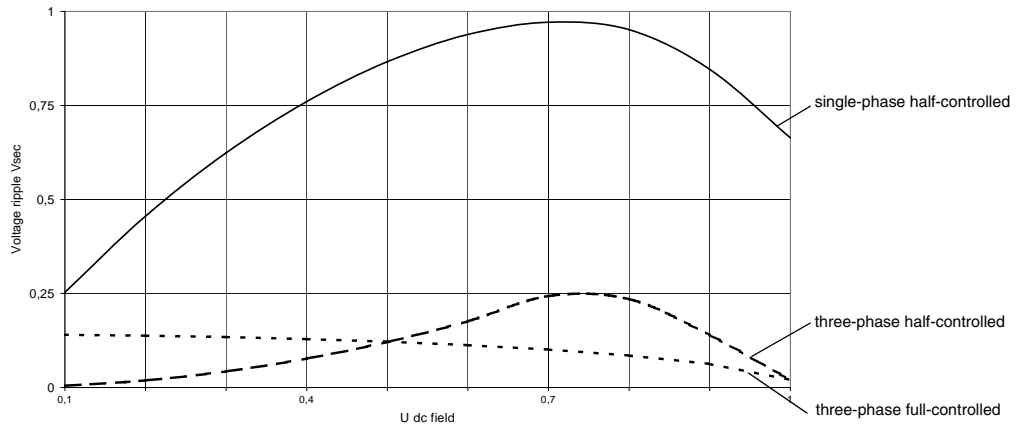

### DCS LINK communication

The field converter is controlled from armature converter via DCS link serial communication based on CAN hardware.

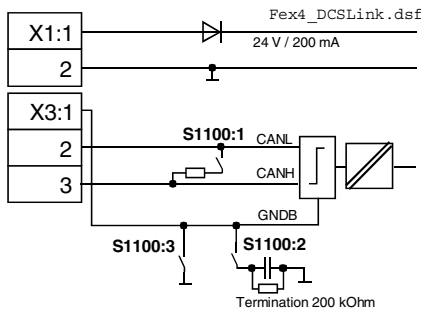

Supply		Remarks
24 V	≤200 mA	24 V grounded supply f. SDCS-FEX-4

DSL communication		Remarks
<b>Bus termination</b>		
S1100	:1 = ON	120 ohm
	:1 = OFF	no termination
<b>Ground termination</b>		
S1100	:2 = ON	200 kOhm R-C ground termination
	:3 = ON	0 Ohm ground termination
	:2, :3 = OFF	no termination

Node address is set by: S800 digit 0 (node address 00 is not possible!)  
S801 digit 10

Same node address must be selected in the corresponding armature converter.  
example: node address=13 ==> S800 = 3 and S801 = 1

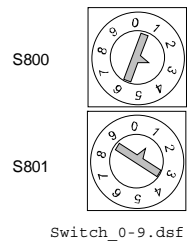

Selection of communication speed is set by S1100

S1100:6	S1100:5	S1100:4	Baudrate kBaud *	Selection of armature converter, param [94.02]
OFF	OFF	OFF	20	0
OFF	OFF	ON	50	1
OFF	ON	OFF	125	2
OFF	ON	ON	250	3
ON	OFF	OFF	500	4
ON	OFF	ON	800	5
ON	ON	OFF	888	6
ON	ON	ON	1000	7

\* see Parameter [94.08], [94.09]

## Diagnosis

All messages are sent to armature converter and displayed by armature converter control panel. If communication is broken or node numbers are mixed up a simple fault display on SDCS-FEX-4 board can be used. Therefore the unit is equipped with two small LED.

U730 = Green

U731 = Yellow

Following messages are displayed:

both OFF	no 24V supply
green and yellow continues	No firmware
green blinking	25 A / 35 A output active, waiting for DCSLINK communication
green continues	25 A / 35 A output active, DCSLINK communication OK
yellow blinking	5A output active (X100:2), waiting for DCSLINK communication
yellow continues	5A output active (X100:2), DCSLINK communication OK

green and yellow toggling:

X times yellow    Y times green

X=1	Y=1	Alarm	phase missed	
	Y=2	Alarm	maximum temperature heatsink	
X=2	Y=1	Fault	DCS link serial communication failed	
	Y=2	Fault	Synchronization fault	
	Y=3	Fault	Overcurrent	
	Y=5	Fault	Field AC supply voltage < 30V	
	Y=6	Fault	Field AC supply voltage < 650V	
	Y=9	Fault	maximum temperature heatsink	
	Y=12	Fault	Auxiliary voltage	
	Y=14	Fault	general hardware	No RESET
	Y=15	Fault	general software	No RESET

### RS232-Port

The RS232 interface is used for download the 'Field exciter firmware package'.

The default settings of this interface are as follows:		X2:	Description
Signal level:	RS232	1	not connected
Data format:	UART	2	TxD
Message format:	Modbus-Protocol	3	RxD
Transmission method:	half-duplex	4	not connected
Baudrate:	9.600 Baud	5	SGND Signal ground
Number of Data bits:	8	6...9	not connected
Number of Stop bits:	1		
Parity-Bit:	odd		

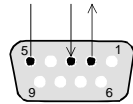

The firmware download is activated by setting S2:1-2 during auxiliary voltage is switched ON. Setting for field exciter mode is S2:3-4 (default).

### FEX425 INTERNAL (Fex-425-Int) Hardware configuration (size D5)

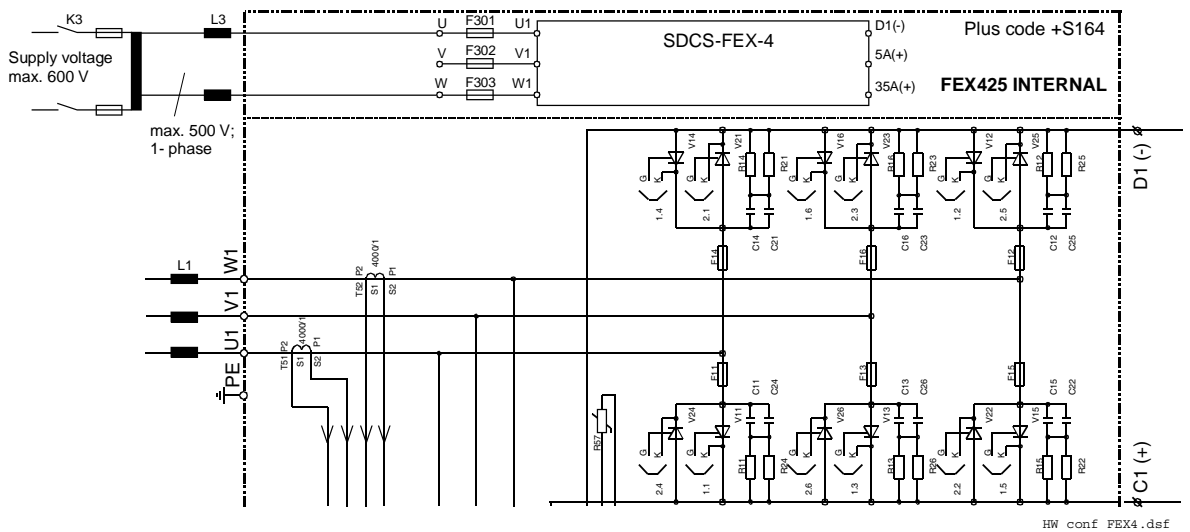
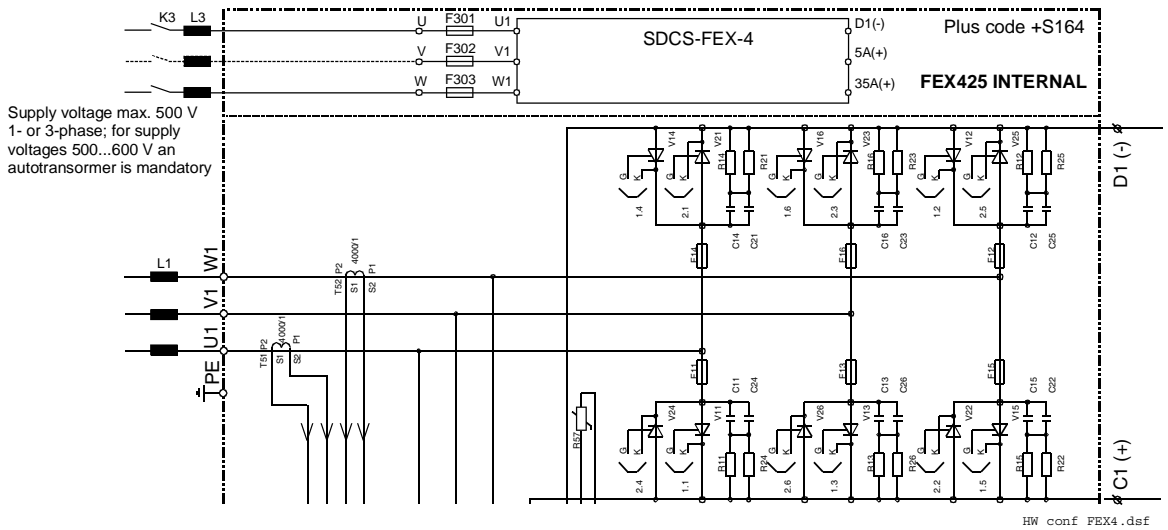

Further information about line reactors see sections *Line reactor L3 (ND30)* and *Line reactors type ND401...413 (ND402)* in this chapter.

**Dimensions**

6 kg

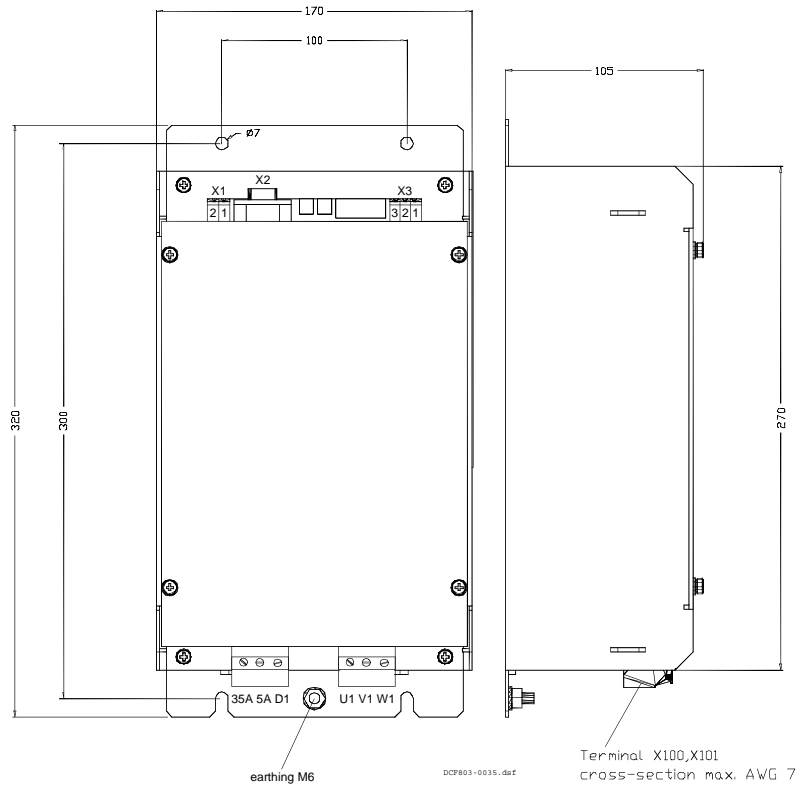

DCF803-0035

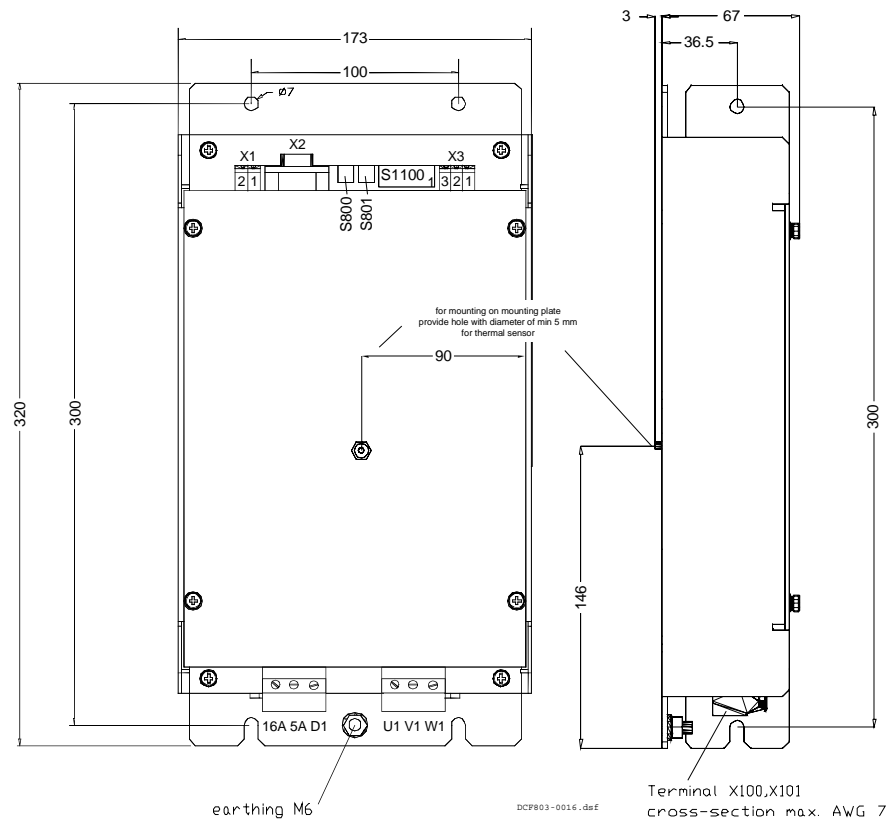

DCF803-0016

**Accessories**

## DCF505 / DCF506 Overvoltage Protection

The three-phase converter can be used as motor field supply. This operation needs a separate active Overvoltage Protection unit DCF 505 or DCF 506 to protect the power part against inadmissibly high voltages.

The protection unit activates a free-wheeling circuit between the F+ and F- connectors if an overvoltage occurs. The DCF 505/506 consists of a trigger unit (SDCS-FEP-x) and a free-wheeling thyristor (two in anti-parallel at DCF 506).

The DCF 506 consist of a relay output to indicate a free-wheeling condition to the field supply converter. When the free-wheeling function is triggered, it will last until the DC current is less than appr. 0.5 A. During this time the relay contacts are closed.

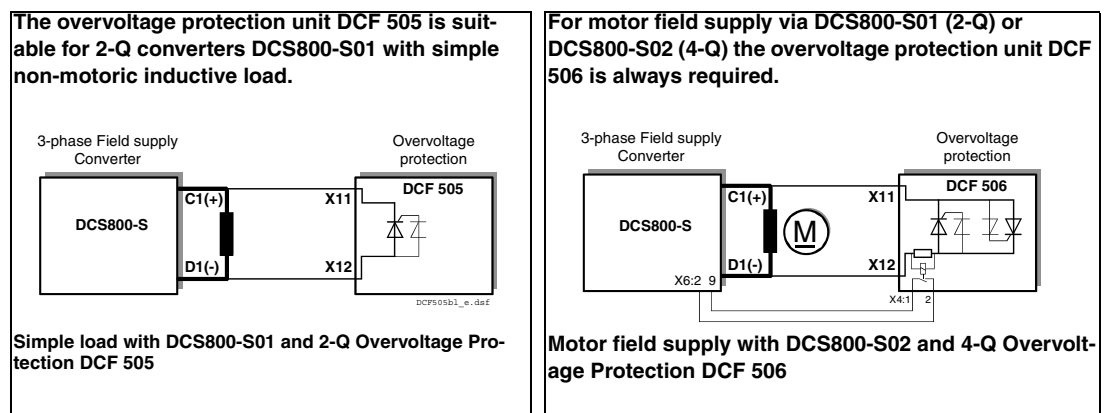

### Assignment Field supply converter to Overvoltage protection unit

Field supply converter for motor fields *	Overvoltage Protection
<b>2-Q, 500 V</b>	
DCS800-S01-0020-05	DCF506-0140-51
DCS800-S01-0045-05	
DCS800-S01-0065-05	
DCS800-S01-0090-05	
DCS800-S01-0180-05	
DCS800-S01-0315-05	DCF506-0520-51
DCS800-S01-0405-05	
<b>4-Q, 500V</b>	
DCS800-S02-0025-05	DCF506-0140-51
DCS800-S02-0050-05	
DCS800-S02-0075-05	
DCS800-S02-0100-05	
DCS800-S02-0200-05	
DCS800-S02-0350-05	DCF506-0520-51
DCS800-S02-0450-05	
<b>Inductive load supply for other applications</b>	
<b>4-Q, 500V</b>	
DCS800-S02-1200-05	DCF506-1200-51
DCS800-S02-1500-05	
<b>4-Q, 690V</b>	
DCS800-S02-0900-07	DCF506-1500-71
DCS800-S02-1500-07	

\* These converter types are released for field supply operation. A derating of 10% is recommended. See also dimensioning of installation (fuses, reactors, contactors).

**Diagramm**

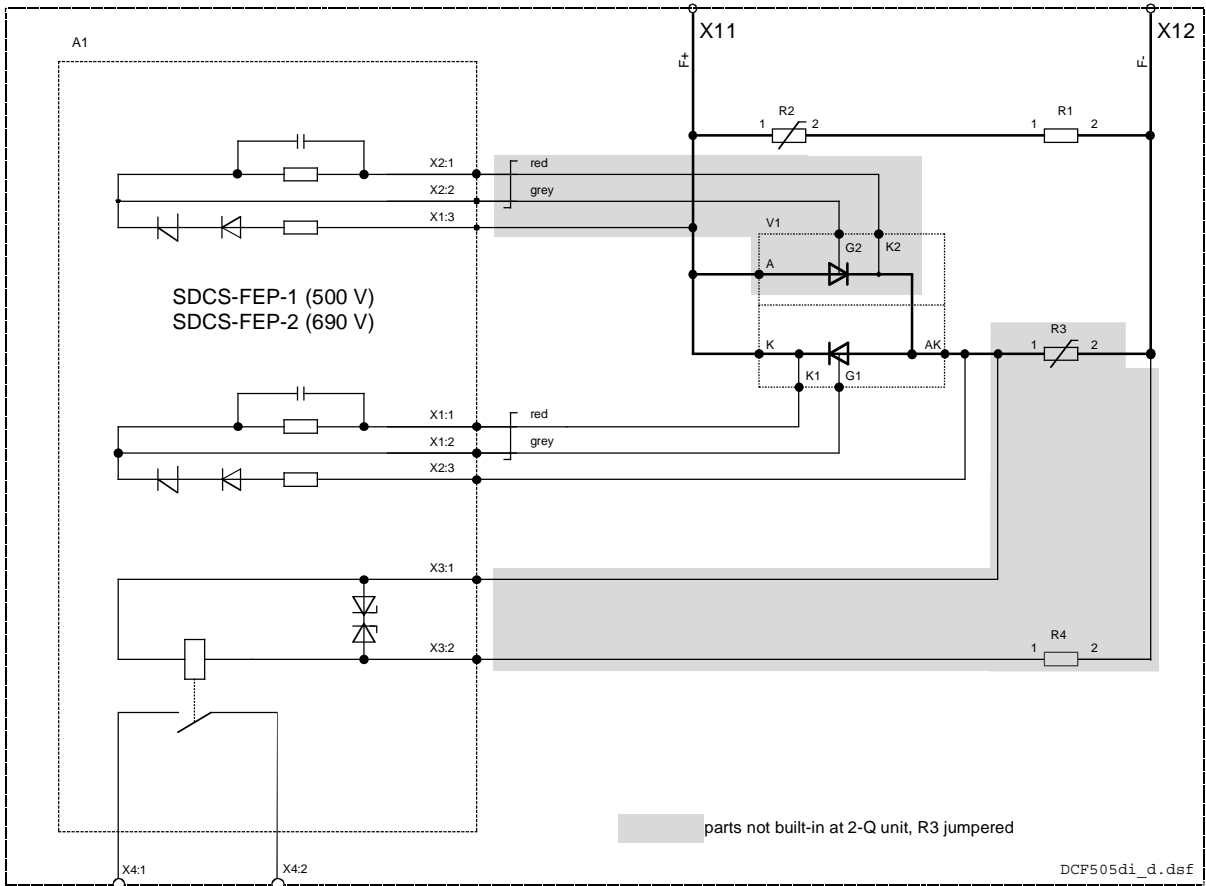

**Overvoltage Protection DCF 505 / DCF 506**

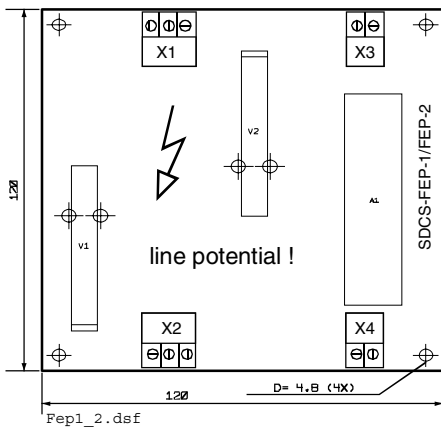

**Output X4:1-2**

Potential isolated by relay (NO contact)  
 Contacts no protected  
 Contact rating: **AC:** ≤60 V~/ ≤50 mA~  
**DC:** ≤60V~/ ≤50 mA-

**Layout of SDCS-FEP-1/FEP-2**

There are two trigger units in use:

- SDCS-FEP-1 for systems, used at line voltages up to 500 V; this board is equipped with a 1400 V trigger diode.
- SDCS-FEP-2 for systems, used at line voltages up to 690 V; this board is equipped with a 1800 V trigger diode.



**Dimensions**

- Overvoltage Protection
- DCF 505-0140/0520-51**
- DCF 505-1200-51**
- DCF 506-0140/0520-51**

Dimensions in mm  
Weight appr. 8 kg

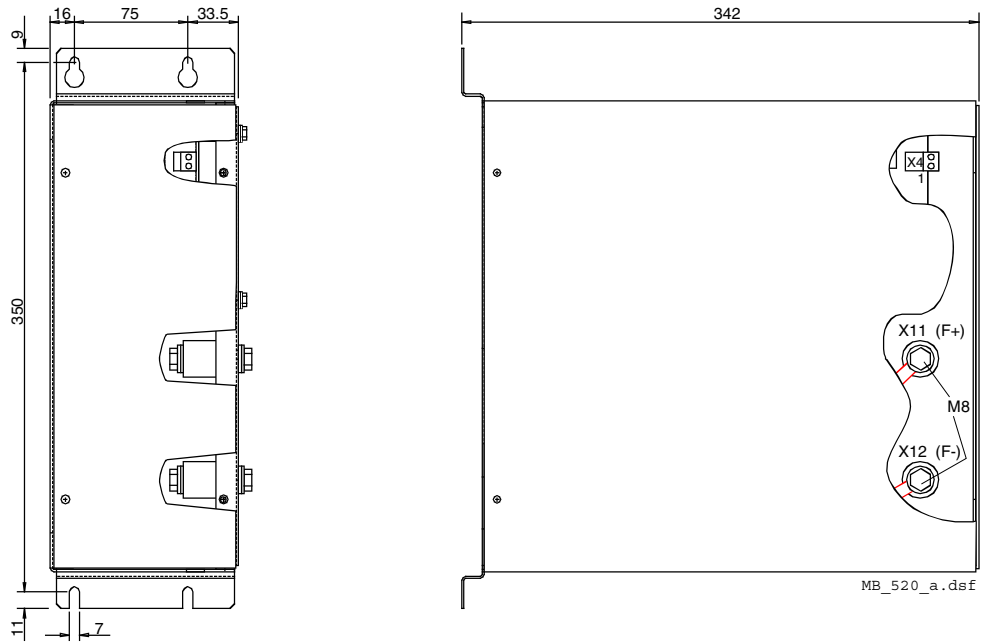

- Overvoltage Protection
- DCF 506-1200-51**
- DCF 506-1500-51**
- DCF 506-1500-71**

Dimensions in mm  
Weight appr. 20 kg

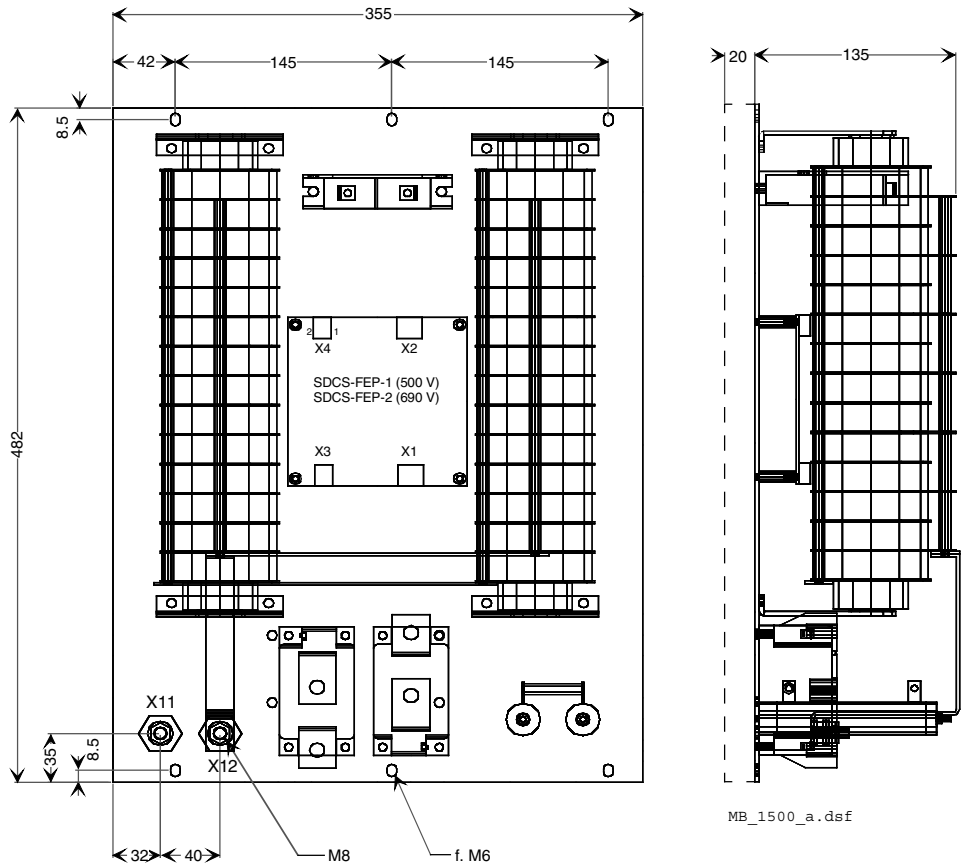

## Fuses and fuse holders IEC

Type	Resistance [mΩ]	Fuse F1	Size	Fuse holder
170M 1558	30	10A 660V UR	0	OFAX 00 S3L
170M 1559	21	20A 660V UR	0	OFAX 00 S3L
170M 1561	15	25A 660V UR	0	OFAX 00 S3L
170M 1564	6	50A 660V UR	0	OFAX 00 S3L
170M 1565	4	63A 660V UR	0	OFAX 00 S3L
170M 1566	3	80A 660V UR	0	OFAX 00 S3L
170M 1568	1.8	125A 660V UR	0	OFAX 00 S3L
170M 3815	0.87	200A 660V UR	1	OFAX 1 S3
170M 3816	0.59	250A 600V UR	1	OFAX 1 S3
170M 3817	0.47	315A 660V UR	1	OFAX 1 S3
170M 3819	0.37	400A 660V UR	1	OFAX 1 S3
170M 5810	0.30	500A 660V UR	2	OFAX 2 S3
170M 6811	0.22	700A 660V UR	3	OFAX 3 S3
170M 6813	0.15	900A 660V UR	3	OFAX 3 S3
170M 6163	0.15	900A 660V UR	4	170H 3006
170M 6166	0.09	1250A 660V UR	4	170H 3006

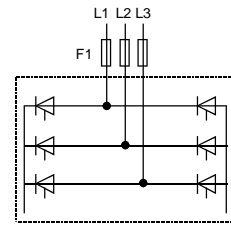

### Dimensions [mm] Size 0...4

Size 0...3

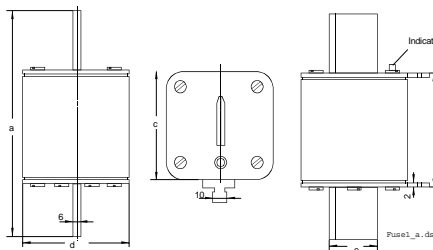

Size	a	b	c	d	e
0	78,5	50	35	21	15
1	135	69	45	45	20
2	150	69	55	55	26
3	150	68	76	76	33

Size 4

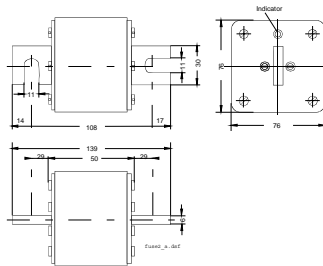

### Main dimensions of fuse holders

Fuse holder	HxWxD [mm]	Protection
OFAX 00 S3L	148x112x111	IP20
OFAX 1 S3	250x174x123	IP20
OFAX 2 S3	250x214x133	IP20
OFAX 3 S3	265x246x160	IP20

OFAX ...

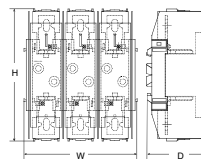

### 170H 3006 (IP00)

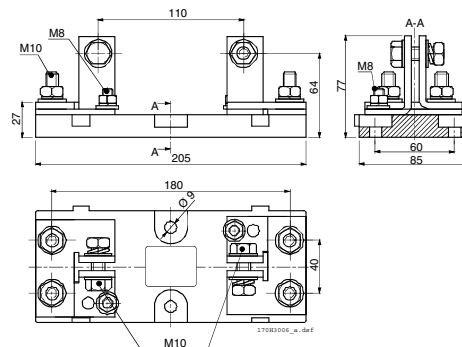

## Fuses and fuse holders - North America

The table shows the recommended fuses and fuse holders for each converter type for the incoming three-phase AC line. If DC fuses are also required, use the same type and size.

Type of Converter		Fuse*	Fuse Holder*	Design Figure
2-Q Converter	4-Q Converter	North America	single-pole	
DCS800-SO1-0020-05	DCS800-SO2-0025-05	FWP-50B	1BS101	1
DCS800-SO1-0045-05	DCS800-SO2-0050-05	FWP-80B	1BS101	1
DCS800-SO1-0065-05	DCS800-SO2-0075-05	FWP-125A	1BS103	1
DCS800-SO1-0090-05	DCS800-SO2-0100-05	FWP-125A	1BS103	1
DCS800-SO1-0125-05	DCS800-SO2-0140-05	FWP-200A	1BS103	1
DCS800-SO1-0180-05	DCS800-SO2-0200-05	FWP-250A	1BS103	1
DCS800-SO1-0230-05	DCS800-SO2-0260-05	FWP-300A	1BS103	1
DCS800-SO1-0290-06	DCS800-SO2-0320-06	FWP-500A	See Note 1	1
DCS800-SO1-0315-05	DCS800-SO2-0350-05	FWP-500A	1BS103	1
DCS800-SO1-0405-05	DCS800-SO2-0450-05	FWP-700A	See Note 1	1
DCS800-SO1-0470-05	DCS800-SO2-0520-05	FWP-700A	See Note 1	1
DCS800-SO1-0590-06	DCS800-SO2-0650-06	FWP-900A	See Note 1	2
DCS800-SO1-0610-05	DCS800-SO2-0680-05	FWP-900A	See Note 1	2
DCS800-SO1-0740-05	DCS800-SO2-0820-05	FWP-900A	See Note 1	2
DCS800-SO1-0900-05	DCS800-SO2-1000-05	FWP-1200A	See Note 1	3

\*Use 3 for the AC side. DC fuses may be required by local safety regulations. If so, use 2 for the DC side.  
 Note 1: No fuse holder is available. Attach fuses directly to busbar.

## Dimensions

Order #	Fig.	A	B	C	D	E	F	G	H	J
FWP-5B-30B	1	2.87	0.563	1.855	2.477	2.477	0.25	0.405	0.063	0.25
FWP-35B-60B	1	4.375	0.813	2.75	3.708	3.312	0.344	0.725	0.125	0.542
FWP-70B-100B	1	4.406	0.947	2.594	3.625	3.563	0.344	0.75	0.125	0.375
FWP-125A-200A	1	5.09	1.5	2.84	4.19	3.5	0.41	1	0.25	0.75
FWP-225A-400A	1	5.09	2	2.84	4.28	3.53	0.41	1.5	0.25	0.78
FWP-450A-600A	1	7.09	2.5	2.84	5.72	4.19	0.53	2	0.38	1.3
FWP-700A-800A	1	6.63	2	2.844	5.562	5.062	0.625	1.5	0.25	0.875

Dimensions in inches.

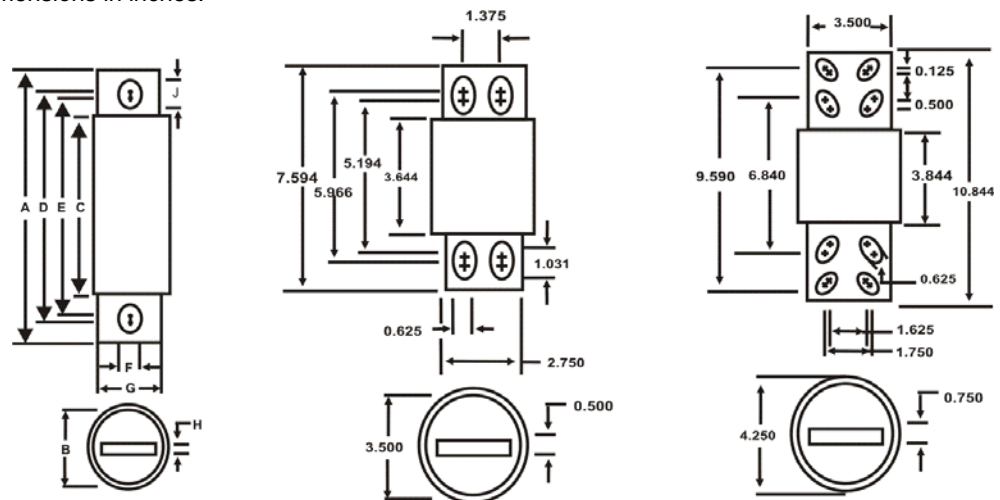

Fig. 1: 5-800 Amp Range

Fig. 2: 900-1000 Amp Range

Fig. 3: 1200 Amp Range

# Line reactors IEC

## Line reactors type ND 01...ND 17

Line reactors ( $u_k = 1\%$ ) for use in industrial environment (minimum requirements), low inductive voltage drop, deep commutation notches.

Line reactors ND01...ND06 are equipped with cables. The bigger ones ND07...ND16 are equipped with busbars. When connecting them to other components, please take relevant standards into account in case the materials are different. Don't use reactor terminals as cable or busbar support!

Type	reactor L [μH]	I <sub>rms</sub> [A]	I <sub>peak</sub> [A]	rated Voltage [U <sub>N</sub> ]	Weight [kg]	Power loss		recommended for armature converter type
						Fe [W]	Cu [W]	
ND 01	512	18	27	500	2.0	5	16	DCS....-0025
ND 02	250	37	68	500	3.0	7	22	DCS....-0050
ND 03	300	37	68	600	3.8	9	20	DCS....-0050
ND 04	168	55	82	500	5.8	10	33	DCS....-0075
ND 05	135	82	122	600	6.4	5	30	DCS....-0110
ND 06	90	102	153	500	7.6	7	41	DCS....-0140
ND 07	50	184	275	500	12.6	45	90	DCS....-0250
ND 08	56.3	196	294	600	12.8	45	130	DCS....-0270
ND 09	37.5	245	367	500	16.0	50	140	DCS....-0350
ND 10	25.0	367	551	500	22.2	80	185	DCS....-0520
ND 11	33.8	326	490	600	22.6	80	185	DCS....-0450
ND 12	18.8	490	734	500	36.0	95	290	DCS....-0680
ND 13	18.2	698	1047	690	46.8	170	160	DCS....-0820
ND 14	9.9	930	1395	500	46.6	100	300	DCS....-1200
ND 15	10.9	1163	1744	690	84.0	190	680	DCS....-1500
ND 16	6.1	1510	2264	500	81.2	210	650	DCS....-2000
ND 17	4.0	1800	2700	800	86.0	250	700	DCS....-2500

Frequency 50 / 60 Hz

### Line reactors type ND 01...ND 06

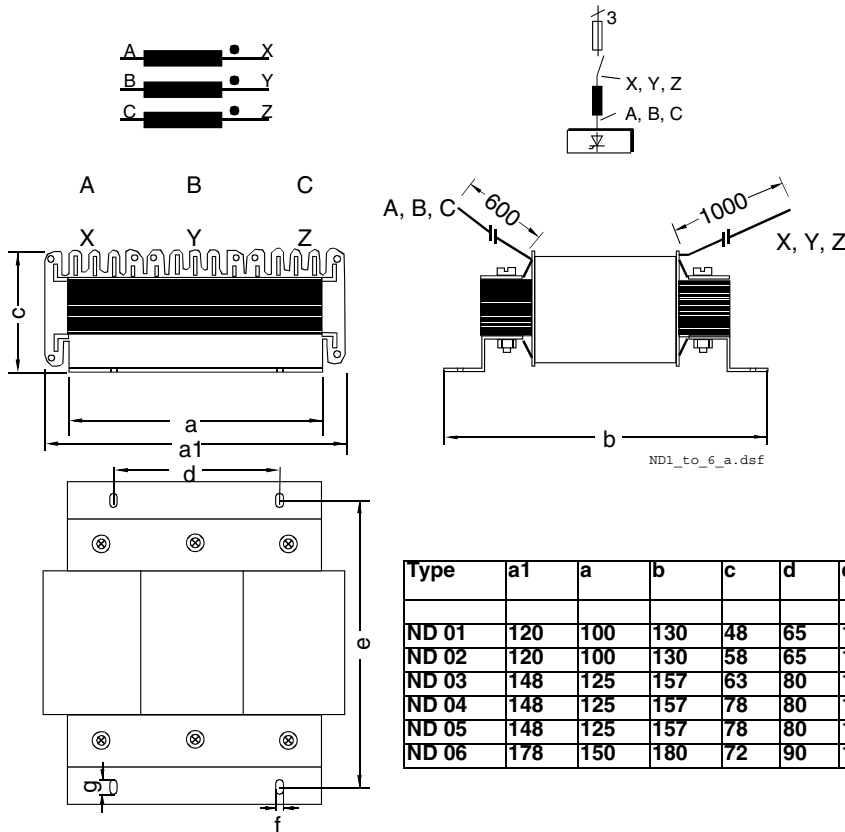



Line reactors type ND 17

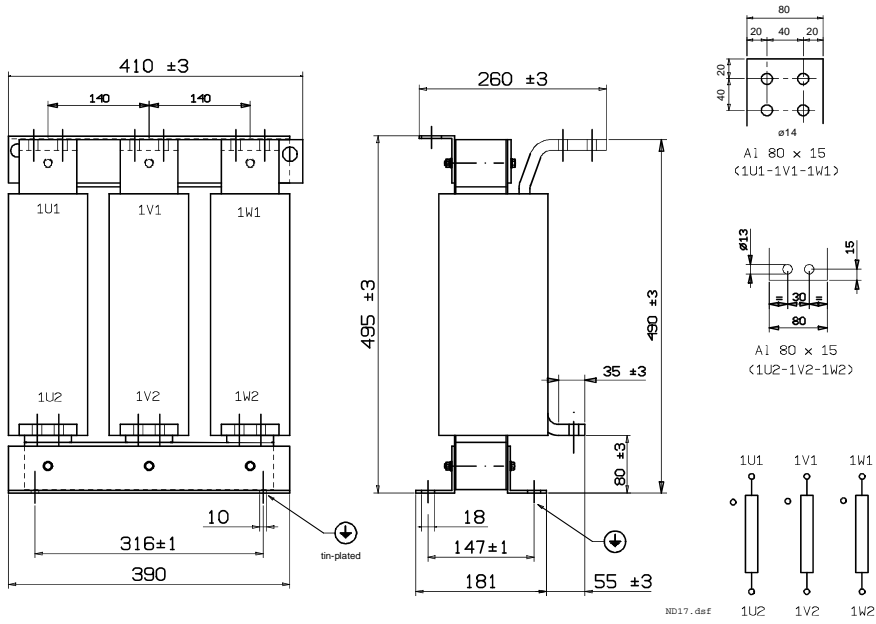

## Line reactors type ND 401...ND 413

Line reactors ( $u_k = 4\%$ ) for use in light industrial/residential environment, high inductive voltage drop, reduced commutation notches.

These reactors are designed for drives which usually operate in speed control mode at 400 V or 500 V networks. Because of that a duty cycle has been taken into account. The percentage taken into account for that duty cycle is different for 400 V and 500 V networks:

- for  $U_{\text{rated supply}} = 400 \text{ V}$ , DC curr. 1 = 90% of nominal current
- for  $U_{\text{rated supply}} = 500 \text{ V}$ , DC curr. 2 = 72% of nominal current

For easier reading the maximum average DC load current is listed instead of the percentage in the next table.

Line reactors ND401...ND402 are equipped with terminals. The bigger ones ND403...ND413 are equipped with busbars. When connecting them to other components, please take relevant standards into account in case the materials are different.

Type	reactor L [ $\mu\text{H}$ ]	$I_{\text{rms}}$ Line AC [A]	$I_{\text{peak}}$ [A]	rated Voltage [ $U_N$ ]	Weight [kg]	Power loss		Load DC curr. 1 (f. $U_{\text{supply}}=400\text{V}$ )	Load DC curr.2 (f. $U_{\text{supply}}=500\text{V}$ )
						Fe [W]	Cu [W]		
ND 401	1000	18.5	27	400	3.5	13	35	22.6	18
ND 402	600	37	68	400	7.5	13	50	45	36
ND 403	450	55	82	400	11	42	90	67	54
ND 404	350	74	111	400	13	78	105	90	72
ND 405	250	104	156	400	19	91	105	127	101
ND 406	160	148	220	400	22	104	130	179	143
ND 407	120	192	288	400	23	117	130	234	187
ND 408	90	252	387	400	29	137	160	315	252
ND 409	70	332	498	400	33	170	215	405	324
ND 410	60	406	609	400	51	260	225	495	396
ND 411	50	502	753	400	56	260	300	612	490
ND 412	40	605	805	400	62	280	335	738	590
ND 413	35	740	1105	400	75	312	410	900	720

Frequency 50 / 60 Hz

## Line reactors type ND 401...ND 402

Type	A	B	C	D	E	F	$\varnothing G$	$\varnothing H$
ND 401	160	190	75	80	51	175	7	9
ND 402	200	220	105	115	75	200	7	9

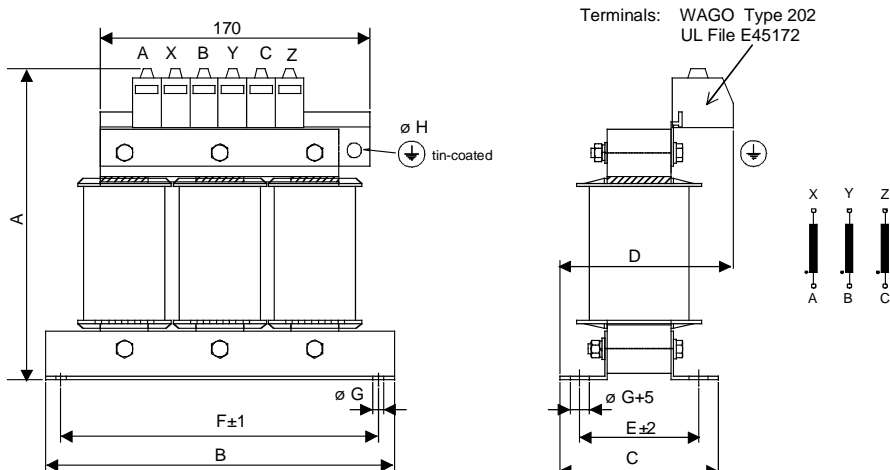

**Line reactors type ND 403...ND 408**

Type	A	B	C	D	E	F	Ø G	Ø H	Ø K
ND 403	220	230	120	135	100	77.5	7	9	6.6
ND 404	220	225	120	140	100	77.5	7	9	6.6
ND 405	235	250	155	170	125	85	10	9	6.6
ND 406	255	275	155	175	125	95	10	9	9
ND 407	255	275	155	175	125	95	10	9	11
ND 408	285	285	180	210	150	95	10	9	11

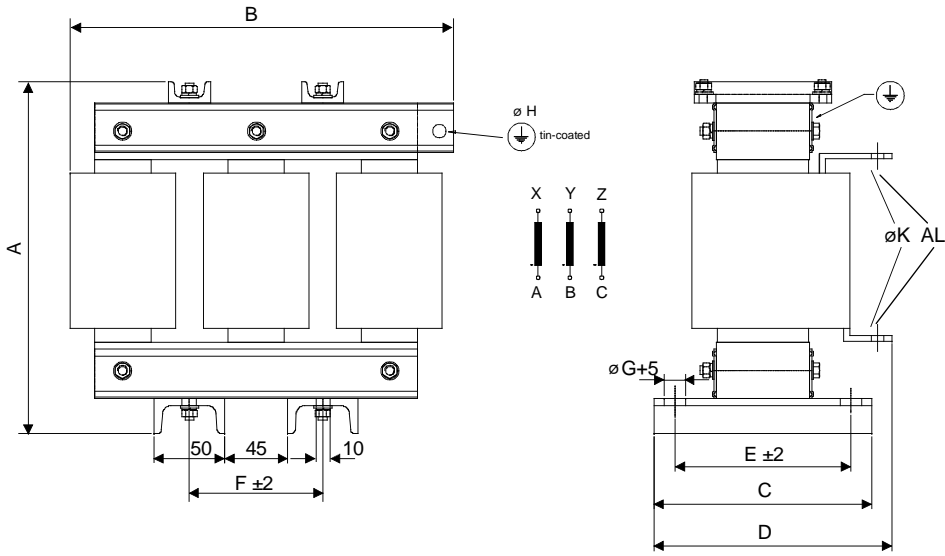

**Line reactors type ND 409...ND 413**

Type	A	B	C	D	E	F	Ø G	Ø H	Ø K
ND 409	320	280	180	210	150	95	10	11	11
ND 410	345	350	180	235	150	115	10	13	14
ND 411	345	350	205	270	175	115	12	13	2x11
ND 412	385	350	205	280	175	115	12	13	2x11
ND 413	445	350	205	280	175	115	12	13	2x11

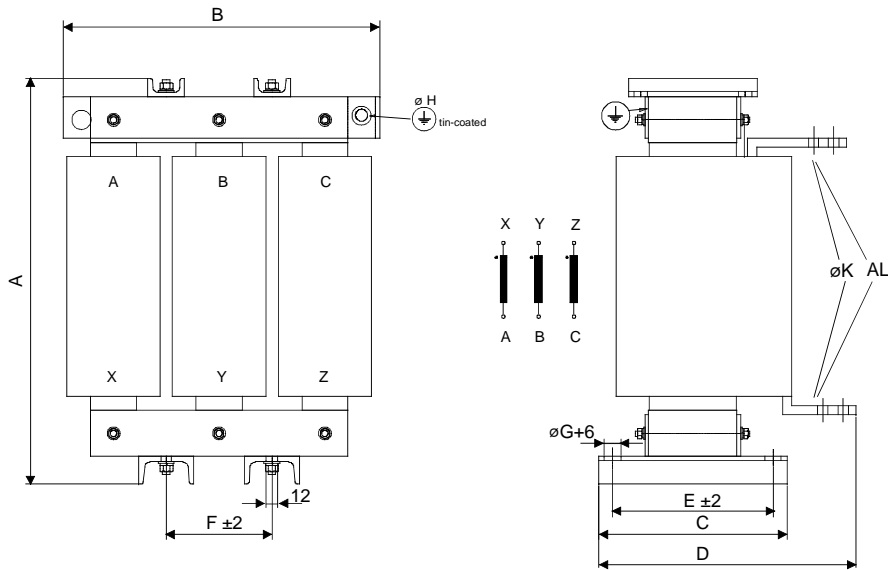



## Line reactors – North America

Unit Type		Line Reactor for Config. A 1.5% Imp.	Line Reactor for Config. B 5% Imp.
2Q Converters	4Q Converters		
500 Vdc			
DCS800-S01-0020-05	DCS800-S02-0025-05	KLR21BTB	KLR21CTB
DCS800-S01-0045-05	DCS800-S02-0050-05	KLR45BTB	KLR45CTB
DCS800-S01-0065-05	DCS800-S02-0075-05	KLR80BTB	KLR80CTB
DCS800-S01-0090-05	DCS800-S02-0100-05	KLR110BCB	KLR110CCB
DCS800-S01-0125-05	DCS800-S02-0140-05	KLR130BCB	KLR130CCB
DCS800-S01-0180-05	DCS800-S02-0200-05	KLR200BCB	KLR200CCB
DCS800-S01-0230-05	--	KLR200BCB	KLR200CCB
--	DCS800-S02-0260-05	KLR250BCB	KLR250CCB
DCS800-S01-0315-05	DCS800-S02-0350-05	KLR300BCB	KLR300CCB
DCS800-S01-0405-05	--	KLR360BCB	KLR360CCB
DCS800-S01-0470-05	DCS800-S02-0450-05	KLR420BCB	KLR420CCB
--	DCS800-S02-0520-05	KLR480BCB	KLR480CCB
DCS800-S01-0610-05	DCS800-S02-0680-05	KLR600BCB	KLR600CCB
DCS800-S01-0740-05	DCS800-S02-0820-05	KLR750BCB	KLR750CCB
DCS800-S01-0900-05	--	KLR750BCB	KLR750CCB
--	DCS800-S02-1000-05	KLR850BCB	KLR850CCB
DCS800-S01-1200-05	DCS800-S02-1200-05	KLR1100BCB	KLR1100CCB
DCS800-S01-1500-05	DCS800-S02-1500-05	KLR1250BCB	KLR1250CCB
600 Vdc			
DCS800-S01-0290-06	--	KLR250BCB	KLR250ECB
--	DCS800-S02-0320-06	KLR300BCB	KLR300ECB
DCS800-S01-0590-06	DCS800-S02-0650-06	KLR600BCB	KLR600ECB
DCS800-S01-0900-06	DCS800-S02-0900-06	KLR750BCB	KLR750ECB
DCS800-S01-1500-06	DCS800-S02-1500-06	KLR1250BCB	KLR1250ECB

**Note:**

Configuration A: For most installations.

Configuration B: For installations that require compliance with EN 61-800-3 or when AC and DC drives are on the same line.

See Chapter "Planning the Electrical Installation" for additional information.

Recommended AC Line Reactors are available directly from TCI.

For information, see their web page [www.transcoil.com](http://www.transcoil.com).

## Autotransformer T3

Type	for Field curr. IF	Transformer's secondary current $I_{sec}$ $U_{prim} = 500\text{ V}; 50/60\text{Hz}$	Weight [kg]	Power loss $P_V$ [W]	Fuse F3 [A]
T 3.01	≤6 A	≤7 A	15	65	10
T 3.02	≤12 A	≤13 A	20	100	16
T 3.03	≤16 A	≤17 A	20	120	25
T 3.04	≤30 A	≤33 A	36	180	50
T 3.05	≤50 A	≤57 A	60	250	63
T 3.11	≤6 A	≤7 A ①	15	80	10
T 3.12	≤12 A	≤13 A ①	20	125	16
T 3.13	≤16 A	≤17 A ①	30	150	20
T 3.14	≤30 A	≤33 A	60	230	50
T 3.15	≤50 A	≤57 A	60	320	63



① 690 V transformer input cannot be used for the field converters SDCS-FEX-4 (isolation only 600 V max.)

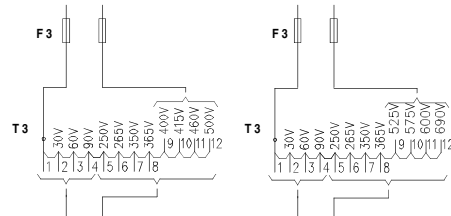
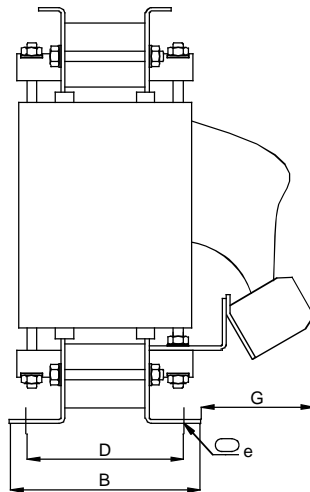
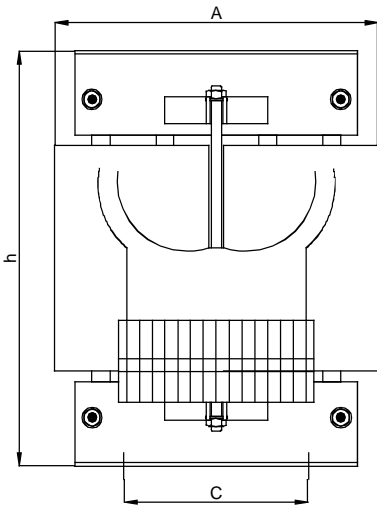

Type	A	B	C	D	h	e	G
T 3.01 / T 3.11	210	110	112	75	240	10x18	95
T 3.02 / T 3.12	210	135	112	101	240	10x18	95
T 3.03	230	150	124	118	270	10x18	95
T 3.04	260	150	144	123	330	10x18	95
T 3.14	295	175	176	141	380	12x18	95
T 3.05 / T 3.15							

## Line reactor L3

for single phase for DCF503-0035 as well as FEX-425-Int

Input voltage: 500 V  
Frequency: 50 / 60 Hz

Type	line reactor data L3			Weight	Power loss	
	L [μH]	$I_{rms}$ [A]	$I_{peak}$ [A]	[kg]	[W]	[mm <sup>2</sup> ]
ND30	2x >500	16	16	1.1	8	2

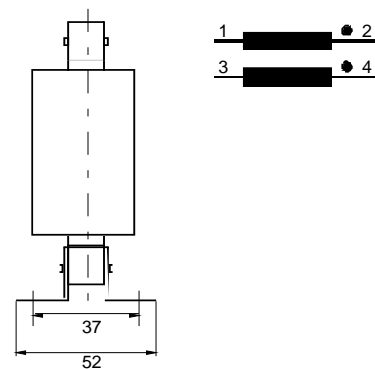
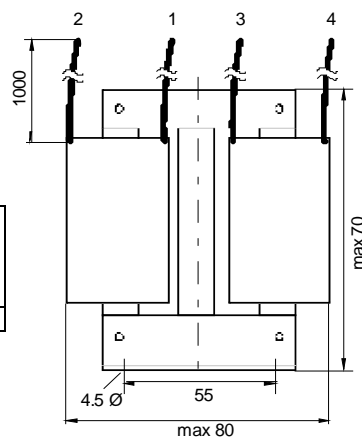

## Supply transformer T2 for electronics and fan

The supply transformer T2 has been re-designed. The new power and current rating allows to supply then 2-phase fans and the electronics by one transformer only in case D5 converters are used in a 12-pulse configuration.

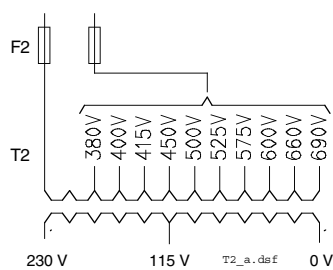

Input voltage: 230/380...690 V/1~; ±10%  
 Frequency: 50...60 Hz  
 Output voltage: 115/230 V/1~

Type	Power [VA]	Weight [kg]	Fuse F2 [A]	I <sub>sec</sub> [A]	Power loss [W]
T2	1400	15	16	6 (0...230 V) 12 (0...115 V)	100

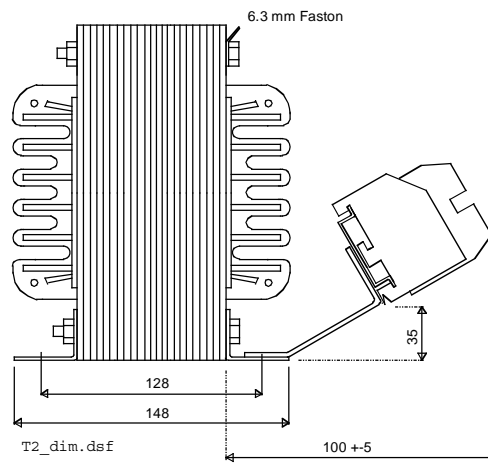
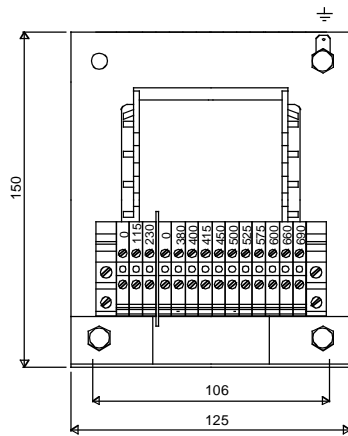

### Application hint:

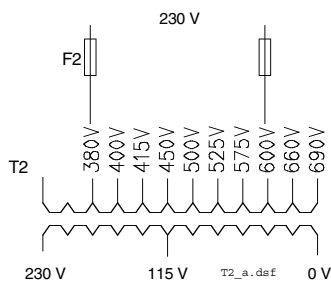

The transformer is designed to work as a 230 V / 230 V transformer to open/avoid ground loops. This is done via the 380 V and 600 V taping according to the left picture.

## Optical cables

For the bus communication of the DCS converters there are different optical cables available.

Kind of cable	Connector	cable length	Ident. no.	Fig.
plastic fibre optic single cable	plug	0.5...20 m	3ADT 693324	1
plastic fibre optic double cable	plug	0.5...20 m	3ADT 693318	2
HCS silica (double) without plastic jacket	plug	30...50 m	3ADT 693355	3
HCS silica (double) with plastic jacket	plug	50...200 m	3ADT 693356	4

Figure 1

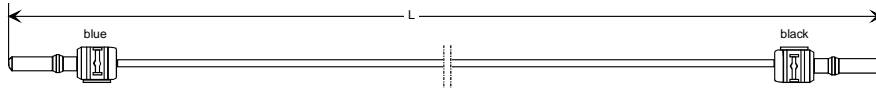

Figure 2

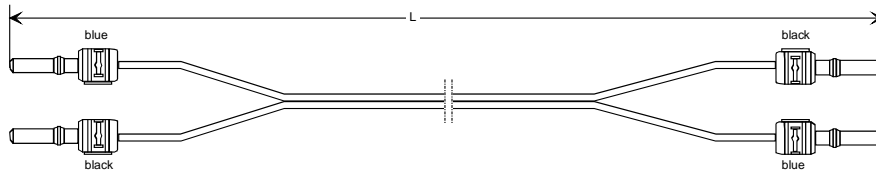

Figure 3

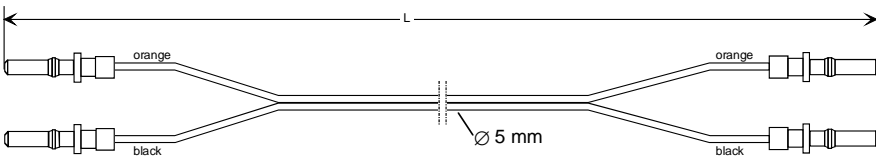
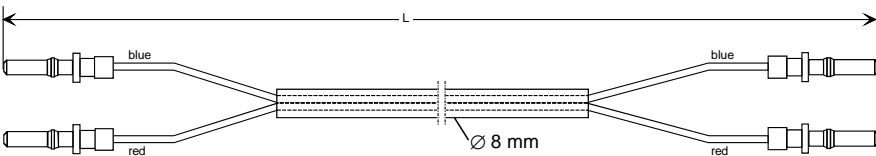

Figure 4



for DCS 400  
DCS 500  
DCS 600  
DCS800

for DCS 600, DCS800 selected channels.  
see manual NDBU 3ADW 000 100 R0201

# Other cables

## DCSLink cable

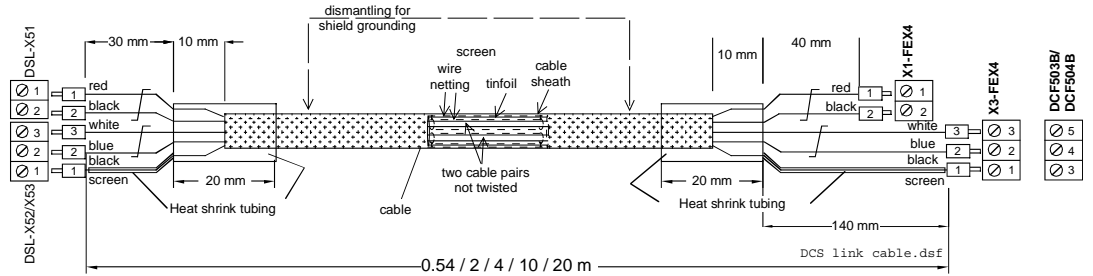

## Unscreened cable for SDCS-CON-4 - SDCS-IOB-2/IOB-3 connection

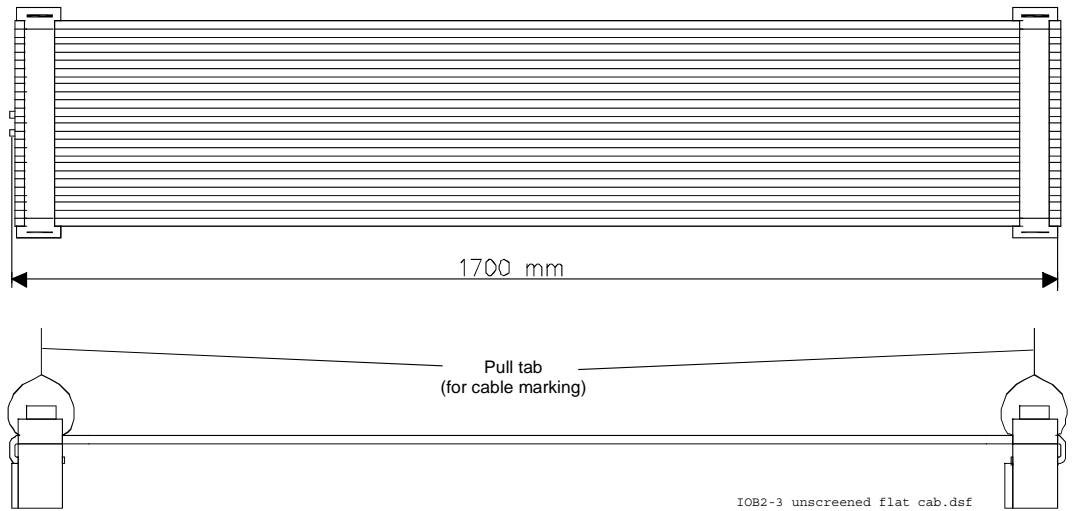

## Screened cable for SDCS-CON-4 - SDCS-IOB-2/IOB-3 connection

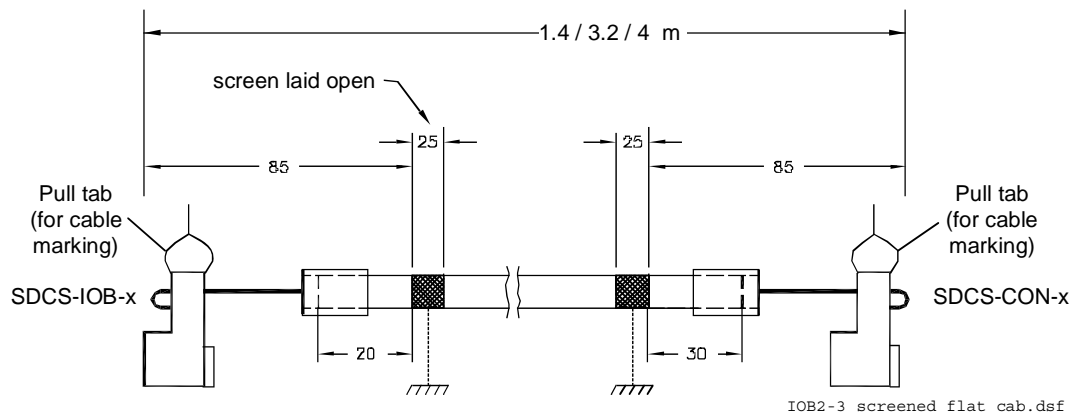



**ABB Automation Products**  
Wallstadter Straße 59  
68526 Ladenburg • GERMANY  
Telefon: +49(0)6203-71-0  
Telefax: +49(0)6203-71-7609  
[www.abb.com/motors&drives](http://www.abb.com/motors&drives)

3ADW000194R0611\_Rev F  
09\_2008



\*194R0611A8370000\*